

 Ontario**Book**
12**Ontario
Traffic
Manual****March 2012**

Traffic Signals

ISBN 978-1-4435-9355-7 (Print)
ISBN 978-1-4435-9356-4 (PDF)

Copyright © 2012
Queen's Printer for Ontario

All rights reserved.

Ontario Traffic Manual

Foreword

The purpose of the Ontario Traffic Manual (OTM) is to provide information and guidance for transportation practitioners and to promote uniformity of treatment in the design, application and operation of traffic control devices and systems across Ontario. The objective is safe driving behaviour, achieved by a predictable roadway environment through the consistent, appropriate application of traffic control devices. Further purposes of the OTM are to provide a set of guidelines consistent with the intent of the Highway Traffic Act and to provide a basis for road authorities to generate or update their own guidelines and standards.

The OTM is made up of a number of Books, which are being generated over a period of time, and for which a process of continuous updating is planned. Through the updating process, it is proposed that the OTM will become more comprehensive and representative by including many traffic control devices and applications specific to municipal use. Some of the Books of the OTM are new, while others incorporate updated material from the Ontario Manual of Uniform Traffic Control Devices (MUTCD) and the King's Highway Guide Signing Policy Manual (KHGSPM).

The OTM incorporates current best practices in the Province of Ontario, and the Manual's primary users are traffic practitioners. The interpretations, recommendations and guidelines in the OTM are intended to provide an understanding of traffic operations and they cover a broad range of traffic situations encoun-

tered in practice. The interpretations and guidelines are based on many factors which may determine the specific design and operational effectiveness of traffic control systems. However, no manual can cover all contingencies or all cases encountered in the field. Therefore, field experience and knowledge of application are essential in deciding what to do in the absence of specific direction from the Manual itself and in overriding any recommendations in this Manual.

The traffic practitioner's fundamental responsibility is to exercise engineering judgement and experience on technical matters in the best interests of the public and workers. Guidelines are provided in the OTM to assist in making those judgements, but the guidelines should not be used as a substitute for judgement.

Design, application and operational guidelines and procedures should be used with judicious care and proper consideration of the prevailing circumstances. In some designs, applications, or operational features, the traffic practitioner's judgement is to meet or exceed a guideline while in others, a guideline might not be met for sound reasons, such as space availability, yet still produce a design or operation which may be judged to be safe. Every effort should be made to stay as close to the guidelines as possible in situations like these, and to document reasons for departures from them.

Custodial Office

Inquiries, suggestions or comments regarding the Ontario Traffic Manual may be directed to:

Ministry of Transportation, Ontario
Traffic Office
301 St. Paul Street, 2nd Floor South
St. Catharines, Ontario
L2R 7R4
Phone: (905) 704-2960
Fax: (905) 704-2888
e-mail: otm@mto.gov.on.ca

Book 12 Acknowledgements

This latest version of the Ontario Traffic Manual Book 12 (Traffic Signals) was made possible as a result of the generous contributions of a number of individuals and their organizations. The contributions of the following are recognized:

Consulting Team Members:

Hart Solomon, CIMA+

Alireza Hadayeghi, CIMA+

Brian Malone, CIMA+

Shervin Shahriari, CIMA+

Brian Applebee, CIMA+

Russell Brownlee, Giffin Koerth

Technical Advisory Committee Members:

Vereen Rattigan, Ministry of Transportation

Roger De Gannes, Ministry of Transportation

Paul Webster, Ministry of Transportation

Ousama Shebeeb, Ministry of Transportation

Kari Fellows, Ministry of Transportation

Dave Kivi, City of Greater Sudbury

Rob Declair, City of Toronto

Shawn Dillion, Region of York

Rick Laing, Region of Peel

Greg Sergeant, City of Ottawa

Ron Gallo, City of Hamilton

Paul Batchelor, Region of Halton / IMSA

Heide Schlegl, Town of Milton / OTC

Mike Flanigan, City of Mississauga

Desktop Publishing:

JLM Studio

Editor:

Nesta Morris

Table of Contents

1.	GENERAL INFORMATION	1
1.1	Introduction	1
1.2	Sections of this book	1
1.3	Use of Terms in This Book	2
1.4	Functions of Traffic Control Signals	3
1.5	Driver Needs and Limitations	3
1.6	Continuity of Operation.....	4
1.7	Traffic Signal Life Cycle Process Diagram	4
2.	LEGAL REQUIREMENTS	7
2.1	General	7
2.2	Highway Traffic Act – Section 144	7
	HTA Statute 144 (31) – Approvals of Signal Designs	7
	HTA Statute 144 (19.1) – White Vertical Bar Indication.....	9
	HTA Statute 144 (13) – Flashing Green.....	9
2.3	Regulation 626 (as amended).....	10
	HTA Regulation 626 Sub-section 1. (1) - Minimum Signal Head Requirements.....	10
	HTA Regulation 626 Sub-section 1. (2) - Vertical Order of Signal Indications	12
	HTA Regulation 626 Sub-section 1. (3) - Use of Circular Signal Indications	13
	HTA Regulation 626 Sub-section 1. (4) - Two Signal Heads Required	13
	HTA Regulation 626 Sub-section 1. (4.1) - Intersection Pedestrian Signals.....	14
	HTA Regulation 626 Sub-section 1. (5) - Height of Signal Heads	15
	HTA Regulation 626 Sub-section 1. (6) - Ramp Metering Signals	16
	HTA Regulation 626 Sub-section 1. (7) - Don't Walk Signals	16
	HTA Regulation 626 Sub-section 1. (8) - Walk Signals.....	17
	HTA Regulation 626 Sub-section 1. (9) - Mounting of Pedestrian Signals.....	18
	HTA Regulation 626 Sub-section 1. (10) - Signals Not At Intersections	19
	HTA Regulation 626 Sub-section 1. (11) - Amber Left Turn Arrows.....	19
2.4	HTA Statute 146 - Portable Lane Control Signals and Regulation 606 (as amended) – Portable Lane Control Signal Systems.....	20
	HTA Regulation 606 Section 1	20
2.5	Proposed Future Legislated Items	20
	Bicycle Signals.....	20
3.	OPERATIONAL PRACTICE	21
3.1	Introduction	21
	General	21
	Standardization	21
	Signal Operations Report.....	21
3.2	Controller Operation	22
3.3	Determination of Intersection Operation.....	23
3.4	Selection of Mode of Control	24

	General	24
	Pretimed (or Fixed Time) Mode	24
	Actuated Mode	25
	Semi-actuated Mode	25
	Fully-actuated Mode	26
	System Operation	26
	General	26
	Coordination	27
	Modes for Isolated Operation	27
3.5	Phase Determination.....	28
	General	28
	Standard Movements	28
	General	28
	Interval Sequence.....	29
	Phase Diagrams	29
	Two Phase Operation	30
	Three Phase Operation.....	30
	Multiple Phase Operation.....	30
	Pedestrian Phases	31
	General	31
	Exclusive Pedestrian Phases	32
	Leading Pedestrian Phases.....	32
	Pedestrian Signal Operation	32
	Left-Turn Phase Justification.....	32
	General	32
	Approximation.....	33
	Analytical Method	33
	Canadian Capacity Guide.....	34
	Determination of the Type of Left-Turn Phase	34
	General	34
	Types of Left-Turn Phasing	35
3.6	Timing	44
	General.....	44
	Minimum Interval Timing	44
	General	44
	Amber and All-Red Clearance Intervals	45
	Clearance for Left-Turn Signals	45
	Level of Service	47
	General	47
	LOS Based on Delay	47
	LOS Based on Probability of Clearing the Arrivals	47
	Determination of Green Interval Timing	47
	General	47
	Canadian Capacity Guide Methodology.....	48
	Highway Capacity Manual Methodology	48

	Ministry of Transportation Methodology	51
	Calculation of Initial Green and Green Extension Time for Actuated Control	51
	Determination of Delays On Actuation	51
	Calculation Of Pedestrian Timing	52
	General	52
	Pedestrian Actuation	53
	Determination of Cycle Length	53
	Guidelines	53
	Cycle Composition	54
3.7	Signal Spacing	54
	New Signalized Intersections	54
3.8	Flashing Operation.....	55
	Advanced Green Flashing Green Ball and Flashing Arrow Operation	55
	Standardized Flashing Amber and Red Operation	55
3.9	Preemption and Priority.....	56
	General	56
	Preemption For Railway Crossings	57
	Preemption For Emergency Vehicles	57
3.10	Miscellaneous Signals	58
	Pedestrian Signals	58
	Transit Priority Signals	58
	Movable Span Bridge Traffic Control Signals	59
	Lane Direction Signals	59
	Automated Flagger Assistance Devices.....	60
	Portable Lane Control Signals.....	60
	Portable Temporary Traffic Signals	60
	Temporary Traffic Signals	60
	Accessible Pedestrian Indications	60
	Pedestrian Countdown Signals.....	61
	Tunnel Signals	61
	Ramp Metering Signals	62
	Optically Programmable Traffic Signals.....	62
	Bicycle Signal Indications, Timing and Phasing.....	63
3.11	Flashing Beacons	63
	General	63
	Hazard Identification Beacons	64
	Beacons in Advance of a Signalized Intersection	64
	Intersection Control Beacons	64
	General	64
	1-Way or 2-Way Overhead Red Flashing Beacons	64
	3-Way and 4-Way Overhead Red Flashing Beacons	65
	3-Way and 4-Way Overhead Red/Amber Flashing Beacons	65
	Red Beacon for Stop Sign Reinforcement	65
	Warning Beacons in Advance of Signalized Intersections	65
	Continuous Advance Warning Beacons for Traffic Signals	65

	Active Advance Warning Beacons for Traffic Signals.....	66
	True Active Advance Warning Beacons for Traffic Signals	67
3.12	Systems	69
	Need for a System	69
3.13	Maintenance Considerations	69
	Traffic Control Subsystem.....	69
	Every 12 months	69
	Traffic Control Subsystem.....	69
	Display Subsystem	69
	External Detection Subsystem	69
3.14	Other Considerations.....	70
	Electrical Considerations	70
	Aesthetic and Practical General Design Considerations	70
4.	PLANNING AND JUSTIFICATION	73
4.1	General	73
	Purpose	73
	Background/Context	73
4.2	Information Requirements	74
	Flow Conditions.....	77
	Intersection / Roadway Configuration.....	77
	Traffic Volume Data	77
	Pedestrian Volume Data.....	78
	Collision Data	79
	Supplementary Input Data	79
4.3	Principles of Justification	79
	General	79
4.4	Justification 1 – Minimum Vehicle Volume	80
	Purpose	80
	Standard	80
	Guidelines.....	80
4.5	Justification 2 – Delay to Cross Traffic	81
	Purpose	81
	Standard	81
	Guidelines	82
4.6	Justification 3 – Volume/Delay Combination	83
	Purpose	83
	Standard	83
	Guidelines	83
4.7	Justification 4 – Minimum Four-Hour Vehicle Volume	83
	Purpose	83
	Standard	84
	Guidelines.....	84
4.8	Justification 5 – Collision Experience	85
	Purpose	85

	Standard	85
	Guidelines	86
4.9	Justification 6 – Pedestrian Volume and Delay	87
	Purpose	87
	Standard	87
	Guidelines	88
4.10	Justification 7 – Projected Volumes	92
	Analysis Using Eight-hour Volumes	93
	Analysis Using Average Hour Volume	93
4.11	Signal Installation Prioritization	94
4.12	Removal of Existing Signals	94
4.13	Collision Experience / Safety Change Estimation	94
	Purpose	96
	Standard	96
	Guidelines	102
4.14	Sample Calculations for Traffic Signal Justification	103
5.	DESIGN PRACTICE.....	111
5.1	General	111
	Use of This Section	111
5.2	Practical Requirements	111
5.3	Safety Considerations	111
5.4	Future Considerations	112
5.5	Signal Visibility	112
	General	112
	Signal Head Locations	113
	Lateral Signal Head Locations	114
	Median Mounted Signal Heads	115
	Mounting Height	115
	Obstruction by Other Signal Heads	116
	Backboards	116
	Auxiliary Signal Heads and Beacons	117
	General	117
	Auxiliary Heads at Bridge Obstructions	118
	Auxiliary Heads at Geometric Curve Obstructions	118
	Obstructions due to Large Vehicles	120
5.6	Pole and Signal Head Locations	121
	Primary Signal Head Locations	121
	General	121
	With Median Islands	121
	Without Median Islands	123
	Secondary Signal Head and Pole Locations	123
	General	123
	With Median Islands	124
	Without Median Islands	124

5.7	Pedestrian Signal Heads	124
	Pedestrian Indications	124
	Guidelines for Pedestrian Signal Head Installation	124
	Guidelines for Pedestrian Pushbuttons.....	126
	Mounting Height and Location	126
	Accessible Pedestrian Signals	126
	Pedestrian Countdown Displays.....	127
	TAC Recommended Operational Guidelines.....	127
	TAC Recommended PCS Standard Layout and Configuration.....	127
5.8	Miscellaneous Traffic Control	128
	Intersection Pedestrian Signals	128
	Mid-block Pedestrian Signals	128
	Lane Direction Signals	128
	Ramp Metering Signals	130
	Signals Near Railway Crossings	130
	Transit Priority Signals	130
	Movable Span Bridge Signals	130
	Temporary Traffic Control and Portable Lane Control Signals	131
	Automated Flagger Assistance Device	131
	Portable Lane Control Signals (PLCS).....	131
	Portable Temporary Traffic Signals.....	132
	Temporary Traffic Signals	134
	Tunnel Signals	134
	Bicycle Control Signals, Placement	134
5.9	Detection	135
	General	135
	Types of Vehicle Detectors	136
	Microwave.....	136
	Infrared	136
	Acoustic.....	136
	Video.....	136
	Pressure Detectors.....	136
	Magnetic Detectors.....	136
	Loop Detectors.....	137
	Presence Loop Detectors	137
	Long Distance Loop Detection	137
	Double Long Distance Detection	139
5.10	Layout Design	143
	General	143
	Crosswalks and Sidewalks	143
	General	143
	Design of Crosswalks and Sidewalks.....	143
5.11	Utilities	147
	General	147
	Guidelines	148

5.12	Layout Practice	149
	General	149
	Guidelines by Example	149
	“T” Intersection Approach	150
	Approach without Median Island (Standard or Advanced Green)	151
	Approach without Median Island (Fully Protected Left Turns)	152
	Approach with Median Island (Standard, Advanced Green or Simultaneous Protected/ Permissive Lefts)	153
	Approach with Median Island (Fully Protected Left Turns)	154
	Approach with Wide Median (Fully Protected Left Turns)	155
	Approach with Double Left Lane (Fully Protected Left Turns)	156
	Ramp Terminal	157
	Short Offset Intersection	158
	Long Offset Intersection	159
	Layout of Pedestrian Heads and Poles	160
	General	160
	Poles with Pushbuttons	160
	Poles with Pedestrian Heads	161
5.13	Controller Locations.....	161
	Coordination	161
	Physical Requirements	161
5.14	Design Example.....	162
	General	162
	Preparation of Base Plan	162
	Layout of Crosswalks and Sidewalks	164
	Pole Locations	165
	Pre-set Head and Pole Locations	166
	Layout of Primary and Secondary Heads	166
	Layout of Pedestrian Facilities	168
	Checking Layout	168
	Controller and Power Supply Locations	168
	Detector Layout	170
	Duct and Wiring Systems	170
	Coordination of Lighting Design	172

APPENDIX A: GLOSSARY	173
ACRONYMS	174
DEFINITIONS	175
APPENDIX B: REFERENCES	183
APPENDIX C: SIGNAL DESIGN AND DRAWING CHECKLIST	187
Requirements and Review	188
1. Geometrics	188
2. Zone Painting.....	189
3. Equipment	189
4. Detection	189
5. Phasing	189

Figures

Figure 1 – Life Cycle Diagram	5
Figure 2 – Traffic Control Signal Heads	11
Figure 3 – Don’t Walk Signal.....	17
Figure 4 – Walk Signals.....	17
Figure 5 – NEMA and 170 Movements.....	28
Figure 6 – Two Phase Diagram	29
Figure 7 – Three Phase Diagram	30
Figure 8 – Multi Phase Diagrams with Fully Protected Operation on the Main Road and Protected/Permissive Operation on the Side Road	31
Figure 9 – Protected / Permissive Single Direction Leading Left-Turn Phasing (Source: TAC Figure B4-1)	38
Figure 10 – Protected / Permissive Single Direction Leading Left-Turn Phasing and Right-Turn Over- lap.....	39
Figure 11 – Protected / Permissive Leading Simultaneous Left-Turn Phasing (Source: TAC Figure B4-2)	40
Figure 12 – Fully Protected Simultaneous Left-Turn Phasing (Source: TAC Figure B4-5)	41
Figure 13 – Permissive / Protected Simultaneous Lagging Left-Turn Phasing (Source: TAC Figure B4-4)	42
Figure 14 – Separate Protected Left-Turn Phasing (Source: TAC Figure B4-9).....	43
Figure 15 – Transit Priority Signal	58
Figure 16 – Lane Direction Signals.....	59
Figure 17 – Signalized Intersection Warning Beacon.....	66
Figure 18 – Active Advance Warning Beacon	66
Figure 19 – True Active Advance Warning Beacon - Recommended Installation	68
Figure 20 – Justification 4 – Minimum Four Hour Justification, Unrestricted Flow	84
Figure 21 – Justification 4 – Minimum Four Hour Justification, Restricted Flow	85
Figure 22 – Justification 6 – Pedestrian Volume.....	87
Figure 23 – Justification 6 – Pedestrian Delay	88
Figure 24 – Current Signal Collision Justification (Justification 5 –Section 4.8)	95
Figure 25 – General Consideration of Safety Changes.....	95
Figure 26 – Detailed Consideration of Safety Changes.....	97
Figure 27 – Justification 5 (Alternative) – Use of Regression Relationship in the Empirical Bayes Approach for Reducible Collisions.....	98
Figure 28 – Justification 5 (Alternative) – Use of Regression Relationship in the Empirical Bayes Approach for Non-Reducible Collisions.....	99
Figure 29 – Safety Changes for Reducible and Non-reducible Collisions for a Typical Case.....	100
Figure 30 – Safety Deterioration Resulted from Converting an Unsignalized Intersection to a Signalized Intersection	101
Figure 31 – Net Safety Benefit Resulted from Converting an Unsignalized Intersection to a Signalized Intersection	102
Figure 32 – Cones of Vision for Signal Visibility.....	113
Figure 33 – Secondary Head Blocking Visibility.....	115
Figure 34 – Auxiliary Heads at Underpass	117
Figure 35 – Auxiliary Heads at Intersection on Curve.....	118

Figure 36 – Use of Continuous Flasher	119
Figure 37 – Use of Active Flasher and Sign	120
Figure 38 – Optically Programmable Heads, Example on Parallel Roads	122
Figure 39 – Primary and Secondary Head Locations	123
Figure 40 – Primary and Secondary Heads Without Islands	125
Figure 41 – Intersection Pedestrian Signals	129
Figure 42 – Presence Loops	139
Figure 43 – Extension Loops.....	140
Figure 44 – Long Distance Detection – Recommended Installation	142
Figure 45 – Double Long Distance Detection – Recommended Installation	144
Figure 46 – Crosswalk and Sidewalk Locations.....	146
Figure 47 – Crosswalk Design.....	146
Figure 48 – Use of Right-Turn Island	148
Figure 49 – “T” Intersection Approach.....	150
Figure 50 – Layout at Approach Without Median Island	151
Figure 51 – Approach with Fully Protected Left Turn Heads and Without Median Island.....	152
Figure 52 – Standard or Protected Permissive Layout	153
Figure 53 – Fully Protected Left Turn Approach	154
Figure 54 – Fully Protected Left Turn at Wide Median Approach.....	155
Figure 55 – Fully Protected Dual LTL Approach.....	156
Figure 56 – Ramp Terminal Intersection Approach.....	157
Figure 57 – Short Offset Intersection.....	158
Figure 58 – Long Offset Intersection.....	159
Figure 59 – Layout of Poles With Pushbuttons.....	160
Figure 60 – Base Plan Features.....	163
Figure 61 – Crosswalk and Sidewalk Modifications.....	164
Figure 62 – Pole Locations Restricted by Utilities.....	165
Figure 63 – Pre-set Signal Locations.....	166
Figure 64 – Primary Head and Pole Layout.....	167
Figure 65 – Secondary Head and Pole Layout.....	167
Figure 66 – Layout of Pedestrian Facilities	168
Figure 67 – Checking Signal Head Visibility and Layout	169
Figure 68 – Controller and Power Location	169
Figure 69 – Detector Loop Layout	171
Figure 70 – Underground Duct System Layout.....	171
Figure 71 – Partial Lighting	172

Tables

Table 1 – Relative Vertical Positions of Signal Indications	12
Table 2 – Capacity Factor for Opposing Lanes	33
Table 3 – Minimum Interval Times.....	44
Table 4 – Amber Clearance Interval Times	46
Table 5 – All Red Clearance Interval Times.....	46
Table 6 – LOS Based on Delay.....	47
Table 7 – LOS Based on Clearing Arrivals.....	47
Table 8 – Rural Intersections: Arrival Rates for Various Levels of Service	49
Table 9 – Urban Intersections: Arrival Rates for Various Levels of Service	50
Table 10 – True Active Advance Warning Beacon Placement	68
Table 11 – Traffic Control Signal Justification: Data Input Requirements	74
Table 12 – Justification 1 – Minimum Vehicle Volume	81
Table 13 – Justification 2 – Delay to Cross Traffic	82
Table 14 – Justification 3 – Volume/Delay Combination	83
Table 15 – Justification 5 – Collision Experience	86
Table 16 – Pedestrian Volume Data Summary.....	89
Table 17 – Pedestrian Delay Data Summary	89
Table 18 – Pedestrian Volume Justification 6A.....	90
Table 19 – Pedestrian Delay Justification 6B	90
Table 20 – Summary Table of Traffic Signal Justification.....	91
Table 21 – Justification 7 – Projected Volumes	92
Table 22 – Future Development: Volume Expansion Required to Meet Justifications	93
Table 23 – Collision Groups for Calibration of OPF.....	97
Table 24 – Collision Severity Indices derived from MTO’s Database.....	101
Table 25 – Signal Visibility Distance	114
Table 26 – Typical Use of Signal Heads and Backboards	116
Table 27 – Distance from Stop Line for Long Distance Loops	141
Table 28 – Long Distance Detection Operating Parameters.....	141
Table 29 – Double Long Distance Detection Operating Parameters	144

1. General Information

1.1 Introduction

Traffic control signals are intended to convey information to the road user. The objective of the information is to advise motorists of traffic regulations in order to encourage compliance with the law, warn of intersecting roadways or road hazards, and provide the information necessary for the driver to safely navigate through the intersection. Simplification of the driving task through uniformity in the design and application of traffic control signals is necessary to accomplish these objectives.

If traffic control signals are not properly designed, installed and operated, they can interfere and distract from each other, become visually ineffective or lose their effectiveness through excessive use. Therefore, simplicity in design, care in placement and a high standard of maintenance is essential. An effective traffic control signal will attract attention, be legible and comprehensible and be appropriate to the road user's needs.

A principal goal in the development of the Ontario Traffic Manual is the achievement of uniformity throughout the Province and compatibility with the rest of Canada and North America. Achievement of this goal requires that the manual provide the user with the design and dimensions of devices and with guidance in the preferred usage and methods of application.

Book 12 of the Ontario Traffic Manual (OTM) is a user manual intended to provide some elementary instructions to beginners and to provide a reference for experienced persons for the design and operation of traffic signals. The intent is to provide a recommended best practice guide. This is not to say that the recommended methods are the only methods, or necessarily the best methods

for the specific set of traffic control signals under consideration, as many factors are involved.

Users should recognize that the planning, design, application and operation of traffic control signals is complex. No manual can provide all the required information, and extensive knowledge and experience are required to be proficient in the field.

1.2 Sections of this book

This manual is organized as follows:

- **Section 1, General Information**, documents general information and basic signal concepts.
- **Section 2, Legal Requirements**, documents legal requirements pertaining to the application of the Highway Traffic Act (<http://www.e-laws.gov.on.ca>).
- **Section 3, Operational Practice**, documents guidelines and recommended practice for operational features.
- **Section 4, Planning and Justification**, documents guidelines and recommended practice for justifying the need for traffic signals.
- **Section 5, Design Practice**, documents guidelines and recommended practice for design concepts, philosophy and details.

The manual refers to various publications produced by the Ministry and other agencies such as the Institute of Transportation Engineers (ITE), the International Municipal Signals Association (IMSA), the Transportation Association of Canada (TAC) and the Ontario Traffic Council (OTC). Links to secure and stable Web sites are listed in the printed version of this manual and live links are provided in the PDF version.

The manual uses acronyms and, of necessity, some industry jargon. A glossary is provided at the back.

Symbols used on layout drawings may be found in Ontario Provincial Standard Drawings¹⁶ Volume 4, Electrical Drawings, Division 2000.

Book 12 of the Ontario Traffic Manual (OTM) was first published in 2001 as a replacement for the Ontario Manual of Uniform Traffic Control Devices (MUTCD), Chapter on Traffic Signals. It was updated in 2007. This latest version of the manual includes updates that reflect recent changes in the industry, changes in legislation, and new material that is of interest to practitioners who design, operate and maintain traffic control signals in the Province of Ontario.

In addition to this new information, some of the suggested methodologies have been updated. The content also reflects new standards and guidelines available in the industry, and emphasizes human factors criteria where applicable. Links are provided to related information inside the manual and to outside sources of information available at the time of publication.

1.3 Use of Terms in This Book

In Ontario, many aspects of traffic control signals are specified in law (for example, the meaning of specific signal indications). Others are based on standards intended to establish consistency throughout the Province. Still other signal aspects are founded on recommendations established through experience. In this publication, specific terms are adopted to convey the differences between the sources of traffic control aspects. These terms and the corresponding meanings are as follows:

“Legal Requirement(s)”, “Legally Required”, “Legal” and equivalent terms mean that the requirement is the law of Ontario as established under the Highway Traffic Act¹⁰ (HTA) and its Regulations. The requirement is typically described by the use of “shall” or “must”. **“Must”** indicates

that the requirements of the design or application of the device as described in this manual are mandatory.

“Interpretation” means the interpretations and emphasis of the legal requirements. The interpretations are not necessarily precise wording interpretations of the HTA¹⁰ and Regulations. The interpretations are given in lay language and may include some industry jargon. The requirements are typically described by the use of “shall”. **“Shall”** means the same as “must”.

“Recommended Practice” suggests a consistent manner in which the legal requirements and interpretations are applied using the typical procedures and equipment in use in Ontario. The recommended practices are not necessarily the only practices available based on the interpretation of the legal requirements or the selection of equipment or methods of operation. The recommendation is typically described by the use of “should”. **“Should”** indicates that the action is advised (recommended but not mandatory).

“Guideline” suggests a method of practical application of the legal requirements and interpretations using the typical procedures and equipment and methods of operation in use in Ontario. The guidelines are meant to provide guidance to those in the traffic signal industry who may be unsure of the methods of application. A guideline has no legal connotation and several alternative methods of achieving the same result may be available. A guideline is typically described by the use of “may”. **“May”** indicates a permissive condition. No requirement for design or application is intended.

1.4 Functions of Traffic Control Signals

The function of a traffic control signal is to alternate the right-of-way between conflicting streams of vehicular traffic, or vehicular traffic and pedestrians crossing a roadway, with maximum safety and efficiency. Safety requires that the traffic control signals operate at the minimum hazard to all road users, including vehicle occupants, bicyclists and pedestrians. Maximum efficiency implies the minimum delay to traffic. Practitioners should consider both safety and efficiency when identifying elements of design or selecting operational practices. In some cases, decisions can result in a benefit to both safety and efficiency (such as properly timed clearance intervals). In other cases, greater efficiency may result in a reduction in safety and vice versa. For example, restricted left turns generally reduce collision frequencies, but increase delays.

The practice of installing traffic control signals for reasons other than right-of-way control has led to installations in some instances where justification is weak. In these cases, traffic waiting at a side road stop sign may have a lower overall delay without a signal than would otherwise occur waiting for a signal change.

Unjustified traffic control signals can lead to excessive delay, increased use of fuel, increased air pollution, increased noise, motorist frustration, greater disobedience of the signals and the increased use of alternative routes in attempting to avoid these types of signals.

Unjustified traffic control signals may alter the number and type of collisions. For example, traffic control signals installed at a location previously controlled by a stop sign may reduce the number of right angle collisions, but increase the number of rear-end collisions. **Therefore, the installation of traffic control signals does not necessarily guarantee a reduction in collision frequency,**

though some signals can be justified on a safety basis only.

A traffic control signal is a control device rather than a safety device. Traffic control signals should not be used for traffic calming schemes, for limiting traffic volumes on specific routes, as speed control devices, as demand control devices, or for the discouragement of motorists and pedestrians from using a specific route.

The justification for traffic signals should be based on studies and needs as outlined in Section 4.

1.5 Driver Needs and Limitations

Traffic control devices are intended to provide vital information to drivers and will be more effective if designed with driver needs and limitations in mind. In particular, consideration must be given to how drivers search the roadway, how driving demands affect what drivers notice, and drivers' tendency to inattention in familiar or monotonous environments.

The visual field of the human eye is very large but only a small area of it allows accurate vision. This central area covers a cone of about two to four degrees, which is an area about the size of a quarter held at arm's length. In order to identify a target, one must look directly at it. When driving, the driver searches the roadway scene in a series of fixations, looking at successive objects of interest.

Studies of driver eye movements show that, while driving, fixations range from 1/10 second minimum up to two seconds or more. At 100 km/h, a driver moves 3 m during the shortest glance. During more complex tasks, like reading a guide sign, a driver can move up to 60 m or more during a single fixation. Thus the number of fixations that can be made, and the number of objects that can be identified as a driver moves through a road section, is quite limited.

Where drivers look is mainly determined by the demands of the driving task. On curves, eye movement studies show that the number of glances a driver makes at the road to maintain lane position doubles. Time available for noticing or reading signs is reduced. At intersections, freeway interchanges, or merges, drivers also face increased visual search demands associated with noting other road users, and have less time to devote to reading signs or noticing unusual roadway features. For this reason, standardization in location and design of traffic control devices is critical in assisting the driver to know where to direct his attention and when.

As environments continue to increase in complexity, the importance of effectively providing information to drivers continues to increase. The standards selected for the design and operation of traffic control signals need to continually promote this effective communication to drivers.

1.6 Continuity of Operation

Unless power has been interrupted, or unusual or emergency conditions prevail at the intersection, a set of traffic signals should always operate with some active indications displayed to the road users. If activities are planned that involve the deactivation of the signal indications, control should be provided by a police officer.

When the traffic signal is to be taken out of service for an extended period of time, the signal heads should be removed or the signal indications covered in such a manner that they are no longer visible to motorists and/or pedestrians.

If some or all of the existing traffic signal heads have to be replaced or relocated due to a collision or reconstruction, an interim installation of temporary signal heads should be considered. It is necessary to maintain the proper and safe operation of

the intersection. If the final repairs will take a considerable amount of time (e.g., longer than it is practical to keep a police officer on site), the interim installation should be considered as being required. The temporary signal heads must conform to the requirements for traffic control signals.

1.7 Traffic Signal Life Cycle Process Diagram

Many of the remaining sections of this book deal with traffic signals at the various stages of the justification, design, and operation life cycle. The detailed life cycle diagram shown in Figure 1 assists in understanding the interrelationship between the various stages. Broadly speaking, the stages include determining the need for signalization, establishing the necessary and required operations, undertaking the design, identifying the ongoing operations and maintenance requirements, and even the possible decommissioning of a signal. Specific details of each process follow in the remaining sections of this manual.

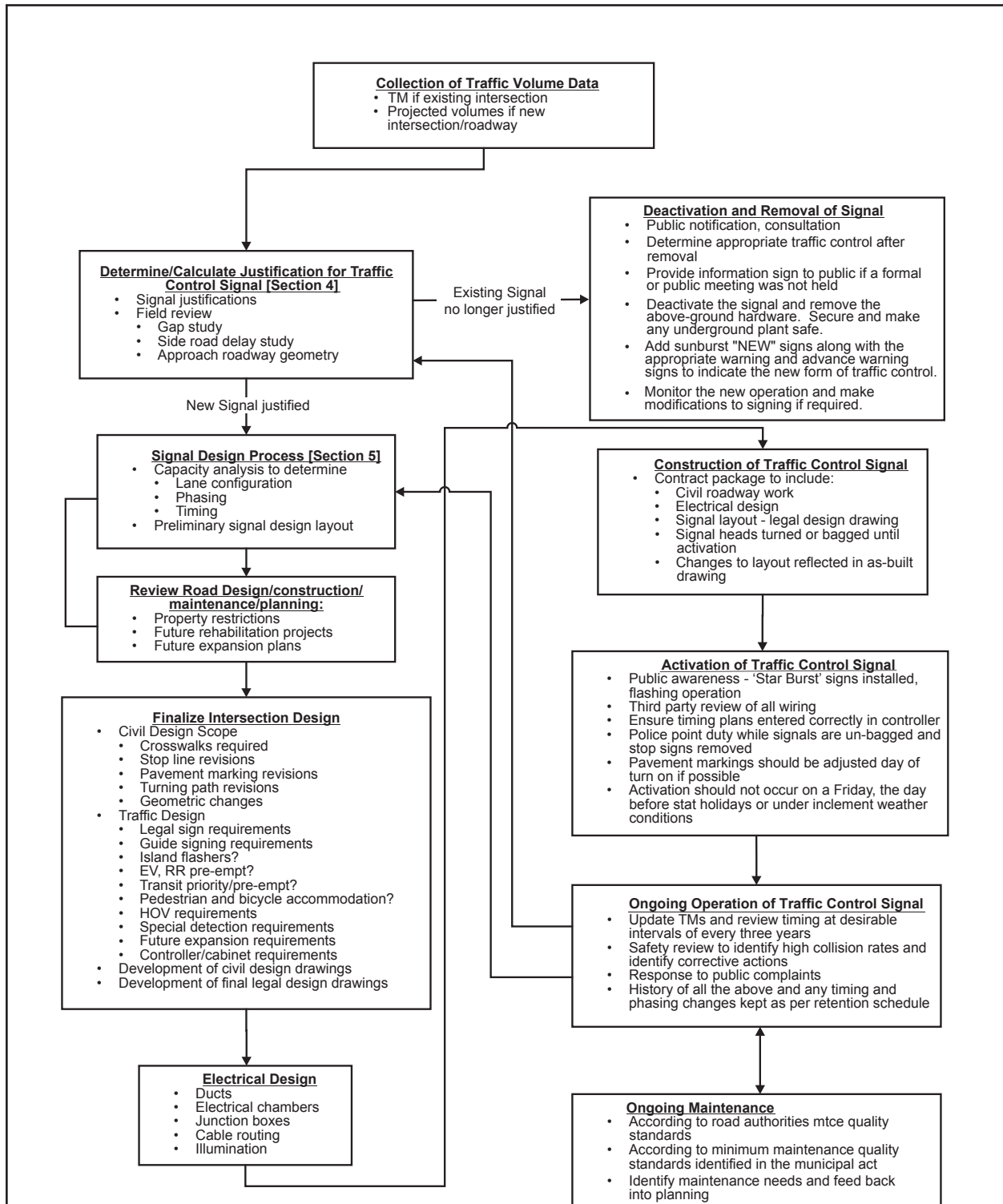

Figure 1 – Life Cycle Diagram

2. Legal Requirements

2.1 General

Section 2 provides an interpretation of various Sections and Regulations of the Highway Traffic Act (HTA)¹⁰ associated with traffic control signal systems and traffic control signals. These Sections include:

- Section 144 – Traffic Signals
- Regulation 626 – Traffic Signal Heads
- Section 146 – Portable Lane Control Signals and Regulation 606 – Portable Lane Control Signal Systems
- Proposed Future – Bicycle Signals

For the purpose of understanding the Regulations of the Highway Traffic Act, “traffic signal control system” means the entire signalized intersection, which includes all electrical components, signage and pavement markings. The system also includes the “traffic control signals”, which are the actual traffic signal heads.

2.2 Highway Traffic Act – Section 144

HTA Statute 144 (31) – Approvals of Signal Designs

1. General

A revision to The Highway Traffic Act (HTA)¹⁰, Sub-section 144 (31), was proclaimed into law in the Ontario Legislature on March 3, 1997.

2. Legal Requirements

The following is the text of the revision:

(31) *“Subject to subsection (31.1), no traffic control signal system or traffic control signal used in conjunction with a traffic control signal system shall be erected or installed except in accordance with an approval obtained from a person designated to give such approvals by the Municipality or other authority that has jurisdiction over the highway or the intersection.*

(31.1) *No traffic control signal system or traffic control signal used in conjunction with a traffic control signal system shall be erected or installed on a highway designated as a connecting link under subsection 21(1) of the Public Transportation and Highway Improvement Act except in accordance with an approval obtained from the Minister or an official of the Ministry authorized by the Minister to grant such approval.”*

3. Interpretation

- i All Road Authorities in Ontario are responsible for designating a person to approve traffic signal designs and installations on their own roadways.
- ii The Ministry of Transportation is responsible for approving traffic signal designs and installations for connecting links.

iii For highways and ramp terminal intersections under Ministry jurisdiction but where the Ministry has entered into maintenance and operations agreements with Municipalities, the particular Municipality is responsible for preparing the legal drawing (PHM-125 format) and submitting it to the Ministry for approval.

4. Recommended Practice

i It is a recommended practice that all road authorities ensure that competent, qualified persons review the design for the traffic control signal system to ensure the design complies with applicable standards and guidelines, thereby optimizing the safety and operation of the signal and assisting in the protection of the road authority should a traffic collision or other mishap occur. In many cases, Municipalities have formally designated the positions responsible for the approval through Council resolutions (although this is not specifically required by law). It is recommended practice that the responsibility for approval should be granted to two people designated to authorize the signal design. It is also recommended that the signal design be represented as a drawing as this is the best way to represent head placements and aiming requirements that are consistent with HTA Regulation 626, this manual and the road authority's internal standards.

ii Where smaller Municipalities are undertaking traffic signal installations or modifications and do not have a person experienced with the work, it is strongly suggested that the Municipalities engage competent, qualified persons with experience and training who can design and/or certify the design before approval by the designated persons of the Municipalities. These persons do not have to be an internal staff member.

iii As a minimum, it is a recommended practice that the traffic control signal system plans should be produced to a scale of 1:200, 1:250 or 1:500. The plans should show the intersection details on all approaches for the distance from the intersection that directly affects the signal operation (not less than 30 m) and should indicate, to scale, the following (minimum) details:

- Edge of roadway (edge of pavement or curb and gutter), sidewalks, islands
- Legal and lane designation signs
- Property access (driveways, curb cuts, ramps)
- Utility poles if signal attachments are required
- The exact location, orientation and type of traffic signal heads and their mounting height
- The exact location and orientation of pedestrian signal heads and pushbuttons
- Geometrics
- Pavement markings (centreline, lane lines, crosswalks, stop lines, turn arrows)
- Blank-out signs and active or continuous flashing advance warning signs or other types of equipment operated by the signal controller
- Vehicle detection devices and their location
- Signs relating to signal operation

iv As a guideline, the following items may also be added to the plan **at the option of the road authority**:

- Location of traffic signal controller cabinet
- Property lines, street lines, building outlines, parking meters and parking control
- Bus bays and bus stops
- Lane dimensions

- v It is recommended practice that if signal heads are relocated, additional signal heads installed, or roadway geometrics/lane configurations modified, the entire installation be re-approved by the designated approval person(s).
- vi It is recommended practice that approval plans should be prepared for both temporary and permanent signals.

HTA Statute 144 (19.1) – White Vertical Bar Indication

1. Legal Requirements

Section 19.1 states “a driver operating a bus or street car on a scheduled transit authority route approaching a traffic control signal showing a white vertical bar indication may, with caution, proceed forward or turn right or left. 1994, c. 27, s. 138 (13)”

2. Interpretation

- i Transit signals apply to the lane(s) occupied by transit vehicles.
- ii Transit signals must also conform to the standards set out in HTA Regulation 626.

3. Recommended Practice

- i It is strongly recommended that all transit operators be educated on the intended meaning of transit signals when the signals are first introduced on a jurisdiction’s roadways.
- ii Where a white vertical bar transit priority section is used, the total number of indications, including the transit section, should not exceed five.

HTA Statute 144 (13) – Flashing Green

1. Legal Requirements

A driver approaching a traffic control signal showing a circular flashing green indication or a solid or flashing left turn green arrow indication in conjunction with a circular green indication and facing the indication may, despite subsection 141 (5), proceed forward or turn left or right unless otherwise directed. (R.S.O. 1990, c. H.8, s. 144 (13))

2. Interpretation

- i. The circular flashing green indication has been used to provide a separate advanced left turn phase to represent the protected portion of a protected/permissive phase in a single direction only.
- ii. The protected portion of the protected/permissive left turn phase may also be provided using a solid or flashing arrow in conjunction with a green ball.

3. Recommended Practice

- i. Ontario is one of only a few users of the circular flashing advanced green in North America and its use may cause some confusion for unfamiliar motorists. In the future, the Highway Traffic Act will no longer recognize the flashing green indication as a valid display. Consequently, it was previously recommended that after January 1, 2010, the use of the circular flashing advanced green should no longer be permitted in Ontario. At this time, the flashing green ball display is no longer a recommended practice and any jurisdictions still operating flashing green ball indications should have plans to remove them or replace them with left turn arrow indications.

- ii. The flashing green arrow indication is a permissible display in Ontario as long as it is for a single direction of travel and not for back-to-back left turns. However, if the flashing green ball indication was in use at a site, consideration should be given to the use of the solid green arrow to provide a period of time as a transition period. Also, during the phase out period, it is strongly recommended that a flashing green arrow not be used in the proximity of intersections with circular flashing advanced greens since drivers may be confused by the different displays.

- iii. The green indication may be composed of a single circular green or a maximum of three green arrows, indicating only right, left and through traffic movements.
- iv. Every circular green indication must have a circular amber indication to indicate that the green interval has ended.
- v. Where the green indication consists of either left, right or through arrows, or any proper combination thereof, shown concurrently with a circular green (for example, with type 10 or 10A heads as per Figure 2), then the arrows indicate single protected movements that are active at the same time as the circular green (and not independently active), and one circular amber indication only shall be used. This type of operation may occur, for instance, at a "T" intersection facing the side road.

2.3 Regulation 626 (as amended)

HTA Regulation 626 Sub-section 1. (1) -Minimum Signal Head Requirements

1. Legal Requirements

Sub-section 1. (1) states: *"Every traffic control signal shall consist of one circular amber and one circular red indication in combination with,*

- (a) *a circular green indication;*
- (b) *a circular green indication and one or more green arrow indications;*
- (c) *a circular green indication, one or more green arrow indications and one or more amber arrow indications; or*
- (d) *one or more green arrow indications."*

2. Interpretation

- i. Every traffic control signal must have a mandatory circular red and circular amber indication.
- ii. Every traffic control signal head must have a mandatory green indication.

3. Recommended Practice

- i. For reasons of simplicity and physical constraints and to increase their effectiveness, it is a recommended practice that **no more than five indications should be combined** in one signal head.
- ii. Where a circular green indication is displayed (indicating that all traffic movements are allowed, i.e., a "permissive" display), only one additional green arrow indication may be displayed in the same signal head at the same time to indicate that either left or right turns, specifically in one direction only, are "protected" from interference from a conflicting traffic movement.
- iii. Where both a circular green and a left green arrow indication are used to allow protected/permissive movements during a single direction left turn, the circular amber indication operates in conjunction with the circular green indication. An amber arrow is recommended to act in conjunction with the green arrow to indicate that the protected portion of the left turn phase is terminating and to be consistent

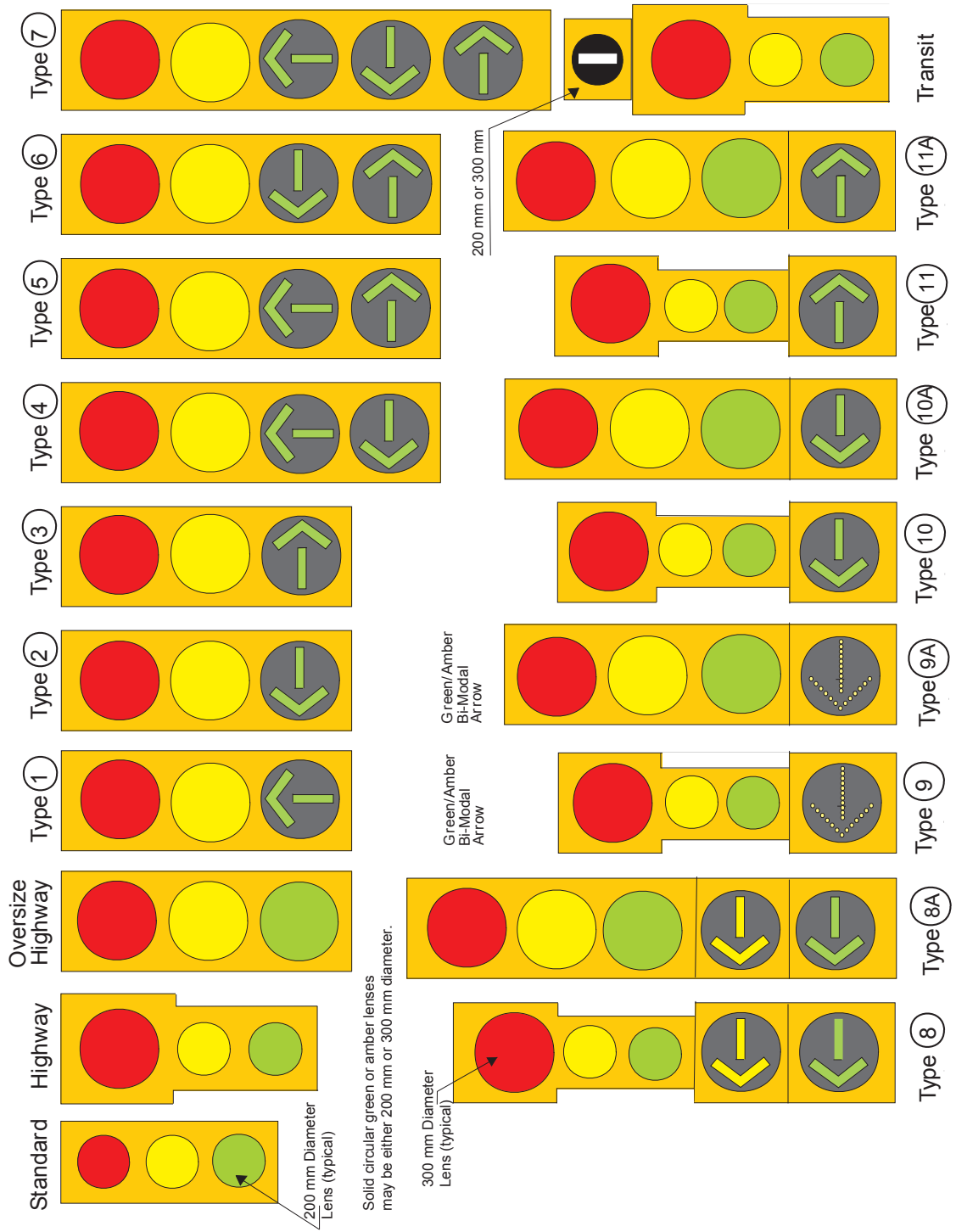

Figure 2 – Traffic Control Signal Heads

with the requirements for simultaneous protected/permissive left turns as given under HTA Subsection 1. (11). Where provided, the left turn amber arrow may consist of either a single arrow that changes from green to amber (type 9 and 9A heads) or a separate amber arrow mounted above the green arrow (type 8 and 8A heads).

iv **The standard indications shown in Figure 2 are the only configurations that should be allowed to be installed in the majority of circumstances** so that the burden of interpretation is not on the motorist. In unusual conditions, it may sometimes be required to use a non-standard signal head that is not shown in Figure 2. This should be done only under the supervision and approval of a very senior and fully experienced traffic engineer/analyst and with the approval of the road authority.

v Lens sizes may be either 200 mm or 300 mm for solid green and amber circular displays in any of the signal heads given in Figure 2. All arrow lenses and all circular red lenses, except the red lens for the "standard" signal head, should be 300 mm diameter.

HTA Regulation 626 Sub-section 1. (2) - Vertical Order of Signal Indications

1. Legal Requirements

Sub-section 1. (2) states: *"Green arrow, amber arrow, circular green, circular amber, circular red and white vertical bar indications may be used for traffic control signals and where they are used, they shall be arranged vertically from the bottom as follows: right turn green arrow, right turn amber arrow, left turn green arrow, left turn amber arrow, straight through green arrow, circular green, circular amber, circular red and white vertical bar."* O. Reg. 65/96, s. 1.

Table 1 – Relative Vertical Positions of Signal Indications

Signal Indication	Comment
White Vertical Bar	Transit Priority Only
Red	Mandatory
Amber	Mandatory
Green	Notes 1 and 3 below
Amber Arrow	Note 2 below
Straight Through Green Arrow	Note 3 below
Left Turn Green Arrow	Note 3 below
Right Turn Green Arrow	Note 3 below

Notes:

1. The circular green indication may be replaced by a straight through, left turn, or right turn green arrow where indicated.
2. The amber arrow direction must be the same as that of the green arrow below it.
3. A green indication, either a circular green or a green arrow, is mandatory on a signal head.

2. Interpretation

- i Whether combined in one unit or mounted as connected sections, the relative vertical locations, from **top to bottom**, of the various indications **must** be as specified in Table 1.

3. Recommended Practice

- i For reasons of simplicity and physical constraints and to increase their effectiveness, it is a recommended practice that no more than five indications be combined in one signal head.
- ii Figure 2 shows the **only types of traffic signal head configurations that should be used due to the need to maintain uniformity** in Ontario (with the exception of lens size which may be either 200 mm or 300 mm for circular lenses). Exceptions to the types of heads shown should only be used where authorized by a senior and experienced traffic engineer/analyst and with the approval of the road authority.
- iii Where a white vertical bar transit priority section is used, the total number of indications, including the transit section, should not exceed five.

HTA Regulation 626 Sub-section 1. (3) - Use of Circular Signal Indications

1. Legal Requirements

Sub-section 1. (3) states: *“No traffic control signal system shall be operated so as to show more than one circular indication simultaneously on the same traffic control signal.”*

2. Interpretation

- i **One circular indication only** (green or amber or red) must be shown if no green or amber arrows are active.

- ii A red indication must not be displayed at the same time as a circular amber or circular green indication, but may be displayed at the same time as any arrow indication(s) on heads which also have a circular green.

3. Recommended Practice

- i In practice, a circular amber indication is displayed immediately after the time of de-energization of a circular green indication (or green arrow indication where a circular green does not exist as in Figure 2, signal head types 1 to 7) such that both the amber and green are not illuminated at the same time.
- ii Similarly, a circular red indication is always displayed immediately after a circular amber indication, but a circular red or green may be displayed after an amber arrow (Figure 2, signal head types 8, 8A, 9, 9A).

HTA Regulation 626 Sub-section 1. (4) - Two Signal Heads Required

1. Legal Requirements

Sub-section 1. (4) states: *“Every traffic control signal system that is installed shall have at least two traffic control signals located on the far side of the intersection from which vehicles are approaching, at least one of which shall be located on the far right side.” O. Reg. 65/96, s. 2.*

2. Interpretation

- i Every traffic approach to an intersection requires that **two signal heads must face oncoming traffic** from the far side of the intersection. The “far side” of the intersection is the half or side of the intersection that is across the intersecting roadway from the traffic approaching the signals.

- ii At least **one signal head must be mounted at the far right hand side** of the intersection quadrant or in an equivalent location on the far right side if there is no intersecting roadway on that side of the intersection.
- iii **Partial signalization or signalization of less than all of the traffic approaches of an intersection shall not be permitted** except for Intersection Pedestrian Signals.

3. Recommended Practice

- i The signal head on the far right side is designated as the “primary” signal head. The signal head on the left of the primary head is designated as the “secondary” signal head. A signal head installed in addition to the primary and secondary signal heads is for the purposes of aiding in signal visibility and is termed an “auxiliary” signal head.
- ii Auxiliary signal heads shall display the same indications at the same times as the primary and secondary heads. If signal head indications are timed differently, they must be on a separate phase from the primary and secondary heads.
- iii Two separate signal heads shall be provided for any **fully protected phase**, such as a left turn operation facing type 2 signal heads, a bicycle phase, or a phase that represents the only opportunity for traffic to be served during a cycle. In the case of the fully protected left turn operation, the type 2 head on the traffic island is the primary signal and the type 2 signal head on the far left side of the intersection fulfills the need for the secondary signal head.
- iv At “T” intersections of publicly owned roadways, any public-use driveway opposite the terminating roadway should be treated as a highway for the purposes of traffic control signals. This indicates that driveways to commercial establishments open to the

public that front onto an intersection, such as schools, churches, and community centres, should be signalized normally.

- v **Private driveways** that front onto an intersection may be provided with traffic control signals. In most instances, it is not necessary to provide traffic signal indications for single-family dwellings or where there is no general public access.
- vi **A protected/permissive left turn** operation facing type 8, 8A, 9, 9A, 10 or 10A signal heads mounted in the median traffic island **must not utilize four signal heads on the same side of the intersection** to ensure the orientation of the heads is distinct from a fully protected type of left operation. A maximum of three heads is permitted, and a minimum of one or a maximum of two of the three heads must display the left turn arrow. The protected/permissive type of operation is intended to protect left turning traffic by operation of a green left arrow when opposing traffic is stopped followed by a circular green indication that permits traffic to proceed through the intersection, turn left when the opposing traffic allows for a suitable gap, or turn right when the intersecting roadway is clear of pedestrian traffic.

HTA Regulation 626 Sub-section 1. (4.1) -Intersection Pedestrian Signals

1. Legal Requirements

Sub-section 1. (4.1) states: *“Despite subsection (4), a traffic control signal system installed at a crosswalk at an intersection for the purpose of assisting pedestrians to cross the roadway shall have*

- (a) *at least two traffic control signals facing the directions from which vehicles on the roadway approach the crossing; and*

- (b) *at least one stop sign facing vehicles approaching the intersection from the other intersecting roadway.” O. Reg. 65/96, s. 2.*

2. Interpretation

- i This subsection allows the use of Intersection Pedestrian Signals (IPS) in Ontario.
- ii **For the roadway being signalized, two signal heads must face approaching traffic in each direction.** The signal heads shall be conventional “standard” or “highway” signal heads as no turns are to be signalized, although a Transit Priority signal head may be used for turning buses.
- iii **The other roadway is always controlled with stop sign(s).**

3. Recommended Practice

- i IPS applications are **intended for use** as an alternative to Pedestrian Crossovers (PXOs). The decision to choose a PXO or an IPS should be based on factors such as pedestrian volumes, pedestrian types (young and seniors), consistency with other traffic control devices in the area, the road authority’s policy, and/or roadway/intersection geometry.
- ii Conventional **pedestrian heads are required** to cross the main roadway as there are no other signal indications facing either direction along the crosswalk.
- iii At this time, it is recommended that the IPS should be restricted to a single crosswalk at any intersection. The opposite side of the intersection requires a pedestrian crossing prohibition sign. (The MUTCDC¹⁴ indicates the use of two crosswalks crossing the main road and this type of IPS is used in some parts of Canada.)

HTA Regulation 626 Sub-section 1. (5) - Height of Signal Heads

1. Legal Requirements

Sub-section 1. (5) states: *“Traffic control signals, where installed, shall not be less than 2.75 metres above the level of the roadway when adjacent to the travelled portion of the roadway and not less than 4.5 metres above the level of the roadway when suspended over the travelled portion of the roadway.”*

2. Interpretation

- i Signal heads shall not be mounted at a height of less than 2.75 m from finished grade to the bottom of the signal head or backboard (clearance point).
- ii All signal heads mounted over the lanes of a roadway, the flare areas of intersections, ramps or any other area normally travelled by vehicles must be mounted at not less than 4.5 m from finished grade to the bottom of the signal head or backboard (clearance point).
- iii It is permissible to mount signal heads higher than the minimum heights given, as long as the height is practical for viewing by motorists.

3. Recommended Practice

- i The recommended practice for mounting of any signal heads over traffic lanes is 5.0 m height, with 5.8 m recommended for span-wire mounted signal heads. It has been found by experience that signal heads mounted at the 4.5 m minimum height sometimes interfere with over-height trucks, loose truck tarpaulins or similar objects and are then damaged. Further, span-wire mounted signals with 8-pole rather than 4-pole configurations may be considered so that the entire assembly is not damaged in the event of a vehicle colliding with a pole.

- ii Primary heads should be mounted at a minimum height of 4.5 m or higher and desirably at a height of 5.0 m regardless of roadway posted speed.
- iii Secondary heads, where mounted on the far left and not over traffic lanes, may be mounted at a minimum height of 2.75 m or higher, and desirably at a height of 5.0 m so that they may be seen from a distance over the tops of vehicles. Intermediate mounting heights between 2.75 m and 5.0 m are useful for improving visibility in congested urban areas where it may be difficult to otherwise keep the secondary heads from being masked by the opposing primary heads. For roads with a posted speed of 80 km/h and over, all secondary heads should be mounted at least at the 5.0 m clearance height.
- iv Auxiliary heads may be mounted at a height of 2.75 m or as high as necessary to obtain good visibility. The desirable height in most cases is still 5.0 m. Auxiliary heads mounted at the far left of the intersection at various heights are normally used to provide better visibility where the left turn lane is often blocked by large vehicles.

HTA Regulation 626 Sub-section 1. (6) - Ramp Metering Signals

1. Legal Requirements

Sub-section 1. (6) states: *“Notwithstanding subsection (5), where a traffic control signal system is installed at a freeway entrance ramp as a part of a traffic management system,*

- (a) *one traffic control signal shall be located to the left side of the roadway not less than one metre above the level of the roadway; and*
- (b) *one traffic control signal shall be located to the right side of the roadway, not less than 2.75 metres above the level of the roadway.”*

2. Interpretation

- i The low-mounted signal head referred to in (a) is required because the stop line is very near to the signal head, and it is necessary that drivers can readily see the head as the metering is accomplished by allowing only one vehicle per lane per green indication through the location.
- ii The primary or right-hand signal head is to be mounted at not less than 2.75 m to give continuity with normal traffic control signals and to allow for reasonable visibility on approach.

3. Recommended Practice

- i This subsection refers to special “ramp metering” signals used on some freeways to control the number of vehicles per hour entering the main freeway traffic. The recommended practices and guidelines for normal traffic control signals do not apply to these special signals because the approach speed is very low, and because the signals are predominantly used in “rush hour” to meter or gate the volumes of traffic, not to allow right-of-way to other vehicles at an intersection.

HTA Regulation 626 Sub-section 1. (7) - Don’t Walk Signals

1. Legal Requirements

Sub-section 1. (7) states: *“A symbol ‘don’t walk’ pedestrian control indication shall:*

- (a) *be rectangular in shape and shall not be less than thirty centimetres in height or width; and*
- (b) *consist of an orange silhouette of a hand on an opaque background as illustrated in the Figure 3.”*

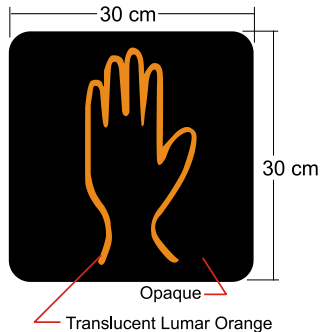

Figure 3 – Don't Walk Signal

2. Interpretation

- i Previous iterations of the pedestrian control signal displaying the words "DONT WALK" must not be used.
- ii The colour of the "hand" shall be orange (not red as per international practice) and the hand shall present an outline figure.
- iii "Opaque" shall mean black or non light-emitting.

3. Recommended Practice

- i Minimum 300 x 300 mm pedestrian control heads should be used.
- ii Light sources for pedestrian control indications must meet the colour requirements of ITE Publication ST-217.
- iii The shape of the orange hand shall conform to the figures provided in the HTA Regulation 626 Sub-section 1 to the satisfaction of the road authority.
- iv The pedestrian control signal shall be mounted at a minimum height of 2.75 m or higher from finished grade to the bottom of the housing (clearance distance) if in a single housing, or at a minimum height of 2.75 m from finished grade to the bottom of

the "walk" section of the head where used independently or as part of a two-section "pedestrian head".

- v Pedestrian control indications shall be mounted so as to be visible along the crosswalk from the opposite side of the roadway at an intersection and shall not be mounted over the travelled portions of roads.
- vi The orange hand ("Don't Walk") or flashing orange hand (Pedestrian Clearance Interval) must not be displayed at any time during which the walking man ("Walk") signal is displayed.

HTA Regulation 626 Sub-section 1. (8) - Walk Signals

1. Legal Requirements

Sub-section 1. (8) states: "A symbol 'walk' pedestrian control indication shall be rectangular in shape and shall not be less than thirty centimetres in height or width and shall consist of,

- (a) in the case of a lens that cannot provide a solid symbol, an outlined symbol of a walking pedestrian in lumiar white on an opaque background as illustrated in Figure 4; or

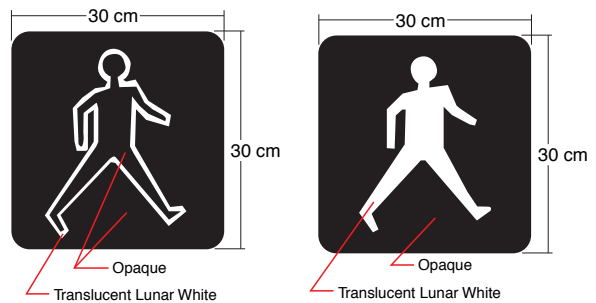

Figure 4 – Walk Signals

- (b) *in the case of a lens that can provide a solid symbol, a solid symbol of a walking pedestrian in lunar white on an opaque background as illustrated in Figure 4.” O. Reg. 213/92, s. 1(1).*

2. Interpretation

- i Standard minimum 300 x 300 mm pedestrian control heads shall be used.
- ii Previous iterations of the pedestrian control signal displaying the word “WALK” must not be used.
- iii The colour of the walking man must be a bright (“lunar”) white (not green as per European and some other international practices) and may be illustrated either as a solid figure or as an outline.
- iv “Opaque” is taken to mean black or non light-emitting.

3. Recommended Practice

- i The walking pedestrian symbol must not be displayed at any time during which the orange hand (“Don’t Walk”) or flashing orange hand (Pedestrian Clearance Interval) is displayed.
- ii Pedestrian control signals shall be mounted at a minimum height of 2.75 m from finished grade to the bottom of the housing (clearance distance).
- iii Pedestrian control indications shall not be mounted over the portions of roads travelled by vehicles and shall be mounted so as to be visible along the crosswalk from the opposite side of the roadway at an intersection.
- iv Light sources for pedestrian control indications must meet the colour requirements of ITE Publication ST-217.
- v The shape of the walking pedestrian symbol shall conform to the figures provided in the HTA Regulation 626 Sub-section 1 to the satisfaction of the road authority.

HTA Regulation 626 Sub-section 1. (9) - Mounting of Pedestrian Signals

1. Legal Requirements

Sub-section 1. (9) states: *“The positions of the symbol pedestrian control indications referred to in subsections (7) and (8) shall be as provided in any one of the following paragraphs:*

- 1. *The symbols are mounted vertically with the hand outline on top.*
- 2. *The symbols are within the same lens and are superimposed over each other.*
- 3. *The symbols are side by side within the same lens with the hand outline to the left.” O. Reg. 213/92, s. 1 (2).*

2. Interpretation

i There are three ways that the standard 300 x 300 mm (minimum) pedestrian control heads shall be used:

- Both displays may be integrated into a single lens with the “hand” symbol superimposed on the “walking pedestrian” symbol.
- Both displays may be integrated in a single lens with the “hand” symbol to the left of the “walking pedestrian” symbol.
- The “walking pedestrian” symbol may also be in a separate section mounted below the hand.

3. Recommended Practice

- i Single head pedestrian heads or two-section pedestrian heads with incandescent lamps may be used.
- ii The walking pedestrian (“Walk”) symbol shall not be displayed at any time during which the orange hand (“Don’t Walk”) symbol or flashing orange hand (Pedestrian Clearance Interval) is displayed.

- iii Pedestrian symbols shall be located at the intersection so as to be visible from the opposite side of the intersection where pedestrians are expected to stand to wait to cross the roadway.

HTA Regulation 626 Sub-section 1. (10) - Signals Not At Intersections

1. Legal Requirements

Sub-section 1. (10) states: *“A traffic control signal system may be erected and maintained at a place other than an intersection, in which event the arrangement of the traffic control signals shall comply as nearly as possible with the provisions of subsections (4) and (5).”*

2. Interpretation

- i This sub-section allows for the installation of:
 - “Midblock Signals” where traffic control signals are installed solely to allow crossing of the roadway by pedestrians.
 - “Traffic Signals” at the intersection of a roadway with a private driveway.
 - Special traffic control signals where it is considered necessary to install signals for the protection of the public. These situations may occur at moveable bridge spans, at rail or transit crossings, at special factory equipment or material moving crossings of a roadway, and at other locations where it is necessary to interrupt the right-of-way of the roadway for good reasons.
 - “Ramp Metering Signals” for control of traffic volumes on ramps entering a roadway (see Subsection for HTA Regulation 626, 1. (6)).
- ii The appearance of traffic signals installed at the foregoing locations shall be consistent for approaching motorists with the appearance of a normally signalized intersection. All

primary, secondary and auxiliary signal heads should obey the legal requirements **as if an intersection were present in front of the activity that is taking place.**

3. Recommended Practice

- i The appearance of the special traffic signals should match the appearance of a normally signalized intersection in the area as closely as practical.

HTA Regulation 626 Sub-section 1. (11) - Amber Left Turn Arrows

1. Legal Requirements

Sub-section 1. (11) states: *“A traffic control signal system that operates as a simultaneous protected and permissive left turn system shall display a left turn amber arrow indication immediately after the display of a left turn green arrow indication.”*

2. Interpretation

- i A simultaneous protected and permissive left turn operation includes opposing left turn movements that overlap but do not necessarily terminate at the same time.
- ii Where both a circular green and a left green arrow indication are used to allow simultaneous protected/permissive movements during a left turn, **an amber arrow must follow the green arrow** to conclude the protected left turn portion of the phase. The left turn amber arrow may be included with the green arrow in a single unit which changes from green to amber, or a separate amber arrow section may be mounted directly above the left green arrow section.
- iii Refer to Section 3 for explanation of the terms “permissive” and “protected”.

3. Recommended Practice

- i Signal head types 8, 8A, 9 or 9A of Figure 2 should be used for the protected/permissive indications;
- ii Flashing green and amber arrows are not allowed for simultaneous left turns.

2.4 HTA Statute 146 - Portable Lane Control Signals and Regulation 606 (as amended) – Portable Lane Control Signal Systems

While HTA Statute 146 discusses the use of Lane Control Signals, legal details for portable lane control signals are all listed in Regulation 606 as noted below.

HTA Regulation 606 Section 1

1. Legal Requirements

Section 1 states: *“Every portable lane control signal system shall consist of at least one set of green, amber and red signal-lights for each direction from which traffic is to be controlled by the system approaches.”*

2. Interpretation

- i Portable lane control signals must conform to the standards set out in HTA Section 146.
- ii A legal approval process is not required for a portable lane control signal.

3. Recommended Practice

- i Portable lane control signals are intended for use on work sites for mobile operations, Very Short Duration or Short Duration Work as Defined in OTM Book 7, Temporary

Conditions. Portable lane control signals should be operated only during daylight hours and should be attended during use.

- ii It is recommended that two signal heads per approach be used in a portable lane control situation and that the second signal head be located in the standard secondary head location.
- iii In the event that a portable lane control signal has to be left unattended or operated for Long Term Duration work as defined in OTM Book 7, Temporary Conditions, the signals should meet the requirements for temporary signals, and a legal drawing should be prepared and approved in conformance with Regulation 626, including the use of at least two signal heads for each approach.

2.5 Proposed Future Legislated Items

Bicycle Signals

1. Legal Requirements

Traffic signals with images of bicycles on the lenses are in use in other parts of Canada. However, the Province of Ontario currently has no legal regulations or statutes for bicycle signals.

Although bicycle signals have no formal status in Ontario, the Transportation Association of Canada is currently formulating usage guidelines and specifications for the symbol. An Ontario jurisdiction wishing to use a bicycle signal would have to apply for permission under section 228 of Highway Traffic Act (HTA).

3. Operational Practice

3.1 Introduction

General

This part of the manual gives an overview of traffic signal operational practice. Operational analysis requires an understanding of the theories of traffic flow and experience in the application of those theories to traffic control signals. References may be found in the Transportation Research Board (TRB) "Highway Capacity Manual"¹¹ (HCM) and in ITE's "Canadian Capacity Guide for Signalized Intersections"¹ (CCG).

It is necessary to use industry jargon to describe hardware and signal operations terms. The reader is referred to the Glossary to obtain an understanding of any unfamiliar terms that are not explained here. One specific term that is widely used by the industry is "traffic control signals". In this section of the manual, the term traffic control signals refers to the system of equipment (e.g., poles, heads, controllers, detectors, etc.) that controls traffic at an intersection. An individual signal indication is referred to as a "traffic signal head" or "traffic signal indication". These terms differ slightly from the legal definitions presented in Section 2.

Standardization

Standardization of the many aspects of traffic control signal operation throughout Ontario is important from the viewpoint of motorists' expectations and safety. Standardization is achieved through the application of:

- Consistent decision-making on the need for and type of traffic control signals
- Consistent signal head use and placement
- Consistent traffic systems engineering/analysis practices in relation to selection of the mode of control
- Consistent decision-making on the need and type of phasing

Items requiring standardization provincially and locally are:

- Operational design of phasing requirements and phase and interval timing
- Timing of clearance intervals
- Determination of phase omissions or additions by time-of-day

Signal Operations Report

A Traffic Signal Operations Study may be undertaken at intersections with operational concerns and at new intersections being considered for signals. The Traffic Operations Study should consider the following elements:

- Collision history at the intersection
- Pedestrian volumes at various times of day
- Turning movements, including truck and bus volumes
- Approach speeds
- Geometric requirements
- Sight distance requirements

- Requirement for phase adjustments (adding or removing)
- Modifications to timing (clearances, minimums, splits)
- Requirements for preemption or priority operations
- Proximity to other intersections
- The need to operate independently or in a system
- Various peripherals monitor the controller circuits: “watchdog” circuits monitor voltages and currents and alert the “Conflict Monitor/Malfunction Management Unit (MMU)” to shut down the signals and revert to “all flash” mode in the event of a conflict, the absence of red signal indications, or low power supply voltage.

It is at the discretion of the roadway authority to select the type and brand of traffic signal controllers.

Chapter 4 provides a methodology for estimating the safety impacts of signalization and may be used in conjunction with the standard signal justifications to determine whether an intersection should be signalized or not.

The Ministry and several large municipalities use the Type 170 signal controller which was developed as a hardware based modular controller. The Type 170 controller is based on a common set of input/output specifications and hardware for any manufacturers to follow. Operational software must be purchased separately and is usually function dependent.

3.2 Controller Operation

This section addresses some of the physical attributes of traffic signal controllers. This section concentrates on solid state controllers, including the Type 170 controller¹⁷ and the NEMA Standard controller^{23, 24}. Although other types of solid state and electro-mechanical controllers are still used by municipalities, they are not discussed in this manual.

Many municipalities use the NEMA specification^{23, 24} controllers, either TS1 or TS2 (Type 1 or Type 2). NEMA is a functional standard that specifies functions that all controllers must follow. The NEMA controller is supplied complete with manufacturers’ software designed to meet or exceed the functional specifications.

Modern signal controllers consist of printed circuit boards with various peripheral devices to control different operations. A simplified description of their operation follows:

All modern controllers provide connections for conflict monitors. Conflict monitors detect the interruption of electronic circuits; signal conflicts on green, amber and walk signals; the absence of sufficient voltage; and the absence of all red signal indications for a given approach. Industry specifications require 170 and NEMA controllers to be operated only with conflict monitors.

- The controller’s Central Processing Unit (CPU) (or Remote Processing Unit (RPU) if the controller is in a system) is programmed using appropriate software to set all timed and actuated intervals and variables, and to allow the required phases for the intersection.
- The computer board sends commands via a 24 volt line to an electronic loadswitch that allows 120 volts to pass through or be cut off from the incoming line to the signal head indications.

Detailed information on controllers may be found in the publications of the major controller manufacturers and in the NEMA^{23, 24} and Ministry¹⁷ specifications.

3.3 Determination of Intersection Operation

The mode of control used (see Subsection 3.4) can have a profound effect on the operational efficiency and safety of any signal. The selection of the best type of control for any location can be made only with full knowledge of local conditions but, in general, can be based on:

- The variation in traffic volumes on all approaches throughout the day
- The volume of pedestrians using each crosswalk
- The percentage of large vehicles
- The volume of specialized vehicles such as bicycles, transit vehicles and emergency vehicles
- The volume of turning vehicles
- The seasonal variations in traffic volumes and characteristics
- The length of time that the signal will be in operation (if temporary)
- The volume of pedestrians with special needs

For any intersection, it is desirable to maximize efficiency of the traffic flow through the intersection and provide a measure of quality of service to pedestrians, motorists, passengers, cyclists and the movement of goods. To achieve these objectives, the ITE's "Canadian Capacity Guide for Signalized Intersections"¹ (CCG) recommends a four-step process which is paraphrased as follows:

1. *Definition of Objectives at an Intersection*

Objectives should be clearly stated and measurable. They may include minimization of average overall vehicle delay, equitable allocation of vehicle or person delay to individual intersection approaches or lanes, maximization of vehicle capacity, control of

queues, minimization of gridlock risk, minimization of vehicle stops, etc.¹.

2. *Analysis*

Analysis includes investigation of intersection conditions and the determination of relevant evaluation, design or planning variables and parameters. Analysis includes consideration of preliminary signal timing, any constraints and the level of detailed traffic input required. The balance between maximum efficiency and optimal safety is only derived from traffic control signals when the lengths of the various intervals are set in accordance with traffic demands with consideration given to the safety of both vehicular and pedestrian traffic.

3. *Planning and Design*

The planning and design step considers future geometric features and the iterative design of the operational parameters. The step may include field surveys for arrival flow, saturation flow, overload factor, average overall delay, average stopped delay and queue length. Appropriate methods are defined in the CCG.

4. *Evaluation*

The evaluation step includes the evaluation of any changes made to the traffic control signals. Because the introduction of new traffic control signals interrupts the traffic flow on all intersection approaches, it is necessary to determine:

- Measured or predicted traffic flow
- Existing or planned intersection geometry
- Cycle composition of traffic movements, phases, phase sequence, and clearance intervals
- Timing design for cycle times that include times for green intervals, walk intervals and clearance intervals
- Intersection capacity, queuing, arrival traffic flow, peaking characteristics, and mode splits

The four steps and associated analyses are discussed in detail in ITE's "Canadian Capacity Guide for Signalized Intersections"¹ (CCG).

Alternately, the practitioner may choose to use a software program to evaluate many of the factors, both local and system. The practitioner should choose the appropriate software based on the particular problem and need. The key to the successful use of any automated approach is a thorough understanding of the assumptions and constants built into the program.

3.4 Selection of Mode of Control

General

The selection of the mode of control at any intersection will depend on several factors:

- Proximity to other signalized intersections
- Operation within an existing area of interconnection
- Operation within an arterial or area wide system
- Variations in traffic flows for each approach by time of day, day of week, and season
- Side street to main street volume relationships
- Volumes of pedestrians crossing the main road
- Percentage of buses and heavy trucks

The following modes of control may be used for isolated intersections (operating independently), within an interconnected system, or for a central system:

Pretimed (or Fixed Time) Mode

A pretimed controller is one that operates within a fixed cycle length using preset intervals and no detection. A pretimed signal is a traffic control signal that directs traffic to stop and permits traffic to proceed in accordance with a single predetermined time schedule or a series of such schedules. Operational features of pretimed signals, such as cycle length, split, sequence, offset, etc., can be changed according to a predetermined set program or plan.

Pretimed control is best suited to locations where traffic patterns and volumes are predictable. The equipment can usually accommodate several plans with differing cycle lengths, splits and offsets. Potential advantages include:

- The consistent starting time and interval duration facilitates coordination with adjacent traffic signals. It also provides more precise coordination than does traffic-actuated control, especially when coordination is needed with adjacent traffic signals on two or more intersecting streets or in a grid system.
- Pretimed controllers do not depend on the movement of approaching vehicles past detectors. Thus the operation of the controller is not adversely affected by such conditions as a stopped vehicle or construction work within the area.
- Pretimed control may be more appropriate than traffic-actuated control in areas where large and fairly consistent pedestrian volumes are present, or where confusion may occur with the operation of pedestrian pushbuttons.
- Generally, pretimed equipment costs less to purchase and install, and it is simpler and more easily maintained than traffic-actuated equipment.

Actuated Mode

An actuated signal is a traffic control signal that makes use of detection to respond to vehicle and/or pedestrian demand. Depending on the number and placement of loops, the operation may be fully-actuated or semi-actuated. Potential advantages include:

- Traffic-actuated control may provide maximum efficiency at intersections where fluctuations in traffic cannot be anticipated and programmed using pretimed control.
- Traffic-actuated control may provide maximum efficiency at complex intersections where one or more movements are sporadic or subject to variation in volume.
- Traffic-actuated control may provide maximum efficiency at intersections that are poorly located within progressive pretimed systems. In these locations, interruptions of main road traffic are undesirable and must be held to a minimum frequency and duration.
- Traffic-actuated control may minimize delay during periods of light traffic because no green time is provided to phases where no traffic demand exists.
- Traffic-actuated control may reduce the number of collisions associated with the arbitrary stopping of vehicles.

Semi-actuated Mode

In semi-actuated control, detectors are located on the side road approaches and in the left turn lanes of the main road. Semi-actuated control is suitable for use at intersections with heavy traffic volumes on the arterial and relatively light volumes on the side road. The signal rests in green on the main road, changing to the side road only as a result of a vehicle or pedestrian actuation.

In the more flexible types of controllers, the duration of the side road green interval varies according to the traffic demand, with provision for a maximum limit. When the minor-street phase expires, the green indication reverts to the major street where it must remain for at least a predetermined minimum interval. When this minimum interval expires, the control is again free to respond to minor street actuation.

As the semi-actuated controller receives no actuation from traffic on the main road through lanes, the controller may assign the right-of-way to the side road at inopportune times (e.g. just before the arrival of a main road platoon of vehicles). The effective use of semi-actuated control is therefore limited to intersections with very lightly travelled side roads, or intersections in coordinated systems where main road progression can be assured.

In a coordinated system, side road actuation each cycle can be limited to a "window" of time that best accommodates a break in the main street progression.

In a semi-actuated controller, side street signal indications are not usually of fixed length, but determined by the side road's changing traffic flow at the intersection. The side street signal indication can occur within a fixed cycle length, or within specified minimum and maximum limits of main and side road green indications. In some cases, certain phases or intervals may be omitted when there is no actuation or demand from waiting vehicles or pedestrians.

Many jurisdictions run the semi-actuated operation using the "mainroad ped recall" feature. In this mode, the controller will cycle back to the main road green/walk interval and rest in this state (called the non-actuated phase) until demands are detected on the actuated phases.

Fully-actuated Mode

Fully-actuated control requires detection on all approaches of both the main road and the side road. Fully-actuated operation is suitable for use at:

- Intersections where the traffic volumes of the main road and the side road are more or less equal but where the traffic distribution may be sporadic and varying
- Locations where turning volumes are high at times and low at other times
- High speed locations where there is a need to avoid “dilemma zone” problems

In rural situations where traffic volumes on both the main road and side road are similar, presence/extension loops may be installed at the stop lines on both roads. The signal phase rests in the green display of the traffic direction last served. Alternatively, a recall for the main road may be programmed so the signal rests on the main road green in the absence of any other demands.

Many fully-actuated intersections use set back loops, which are located in each lane upstream from the intersection. The loops can be operated in a variety of ways. For example, set back loops can count the number of vehicle actuations during a red phase and provide a green time that is based on the number of actuations.

Another variation of fully-actuated operation is commonly used on roadways posted at 80 km/h or greater where the side road is actuated but the main road rests in green. Set back loops are used to extend the green. This form of control is referred to as “long distance detection” and is described in detail in Section 5.

System Operation*General*

A system can vary from two or more interconnected controllers to large centralized computers controlling thousands of intersection controllers. System intersections may be controlled as follows:

- Local controllers at each intersection are controlled by a field master controller.
- Local controllers at each intersection are controlled by a central computer (normally a PC for small systems). Each controller can have its own dedicated connection to the central computer or a group of controllers can be connected to the central computer via a master controller.

With the exception of signal systems using traffic adaptive software, systems use a common cycle length and have a definite offset relationship for all system intersections. Any system that accommodates traffic progression offers the following advantages over isolated/independent operation:

- Traffic is processed into tightly spaced groups, or platoons, with gaps between platoons. The gaps may be used for vehicle or pedestrian crossing times on sideroads, at unsignalized intersections, or at entrances between signalized intersections.
- Although delay may be increased on sideroads, stops for main road traffic are reduced and overall delay is generally decreased.
- Increased intersection capacity is achieved by decreasing the number of queued vehicles and thereby decreasing startup delays.

- The number of collisions is reduced by reducing the speed differential between individual vehicles.
- Fewer rear-end collisions occur due to fewer stops.
- Fuel consumption, noise and air pollution are all reduced due to fewer stops and lower delay.
- Maintenance benefits are achieved by reducing field visits required to update timing plans, and by providing quicker response to problems through earlier notification of equipment malfunctions.

Coordination

Coordination may be considered advantageous where intersections are spaced less than 1.0 km apart with posted speeds less than 80 km/h, or where intersections are spaced less than 1.5 km apart for posted speeds of 80 km/h and over.

In a simple coordinated system, different timing plans may be selected on a time-of-day basis or on a traffic responsive basis. In traffic responsive systems, vehicular volume and density (occupancy) are measured by detection devices in the roadway, and appropriate cycle lengths and offsets are chosen for programming into the master controller or central computer.

In a more complex traffic adaptive system, the traffic is continually travelling over loops placed downstream of all intersections and the central computer calculates and applies new cycle lengths, splits and offsets to better accommodate the traffic flows.

Where good progression is possible, pretimed operation can promote the formation of tight platoons of traffic. This is because vehicles entering the coordinated route will usually be released

from the first intersection with a high probability of staying within a green band (successive greens).

Actuated control may allocate unused phase time from the actuated phases (side streets or main street left turns) back onto the main street further increasing progression opportunities, but decreasing the certainty of the progression pattern. Actuated control simulates pretimed control when vehicle volumes on the side street are high enough to lead to continuous vehicle actuation and cause the side road to go to the full phase time allowed.

Design and analysis software is available for coordination and network analysis. The coordination calculation is designed to progress traffic through a particular set of traffic signals along an arterial by using an offset time at each intersection. When determining offsets, preference is normally given to the direction with the higher traffic demands.

The effectiveness of two-way progression is a function of intersection spacing, cycle lengths, and the number of signals in the control area. When controlling a grid network, the balancing of directional preferences is more difficult than for single arterials, but similar principles are used.

Modes for Isolated Operation

When a traffic signal is running isolated from other surrounding signals, it does not necessarily have to operate in a coordinated manner and therefore does not need a constant cycle length. Actuation of vehicle phases is generally the most efficient means of operating isolated signals if traffic volumes vary. Similarly, pedestrian actuation is generally the most efficient means of operating the signals if pedestrians are not present for the majority of signal cycles.

3.5 Phase Determination

General

The number of phases required for efficient operation depends on the physical characteristics of the intersection, collision trends and patterns, and the through and turning movements taking place. The smallest practical number of phases should always be used to reduce the “lost time” due to clearance intervals between phases.

Guidelines are available in ITE’s “Canadian Capacity Guide for Signalized Intersections”¹ (CCG).

Where the volume of vehicular or pedestrian traffic entering or crossing one or more approaches is sufficient to impact the operation of the intersection, but not sufficient to justify a completely separate phase, one or more of the normal phases may be split or programmed as a “subordinate” phase to provide an interval within the associated or parent phase. An advanced green combined with a through movement is an example of a subordinate phase.

The number and type of phases required will largely depend on the volumes and intersection geometrics. The number of required phases and their sequence constitute the cycle structure.

Standard Movements

General

It is recommended that the standard traffic movements be identified by number according to the type of controller. The type 170 controller¹⁷ and the NEMA type controller^{23,24} use similar numerical methods to identify phases. However, by convention, the side street phase numbers used by 170 and NEMA controllers are reversed.

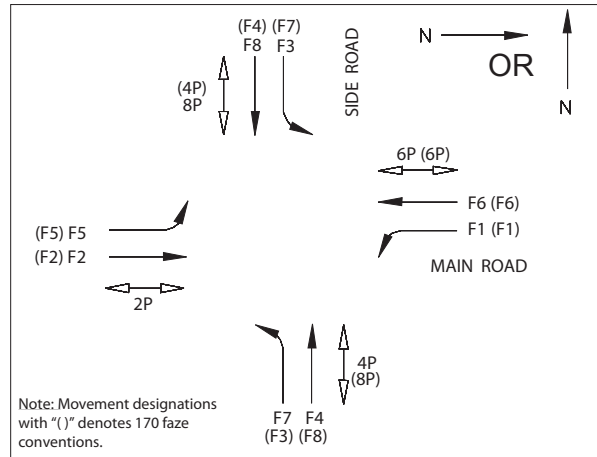

Figure 5 – NEMA and 170 Movements

The NEMA convention for traffic movements is shown in Figure 5. “F” designates a “faze” (movement) number, and “P” designates a pedestrian movement number. The following convention is used:

- The through fazes are even numbers starting with faze 2 (always on the main road) in either the northbound or eastbound location and progressing counter-clockwise around the intersection (clockwise for 170 controllers).
- Unless separate signal indications are provided, the right turn movements are usually represented by the faze number designated to the adjacent through movement.
- The left turn fazes are odd numbers, starting with faze 1 (always on the main road) in the southbound to eastbound or the westbound to southbound direction and progressing counter-clockwise around the intersection (clockwise for 170 controllers).
- Faze 1 always opposes faze 2. Odd number fazes are always left turn movements and even numbered fazes are always through movements.

Interval Sequence

A phase can be broken down into a sequence of intervals. An interval may be defined as a period of time during which the signal indications do not change. An interval may include, for example, a green ball and green arrow, or a solid amber ball indication. The traditional normal sequence of indications is indicated in a phase “diagram”:

Phase Diagrams

It is recommended that phase sequence diagrams be on or attached to the approved signal timings to ensure the phasing matches the signal layout shown. The phase sequence diagram should include the following information:

- Each lane should be shown.
- The signalized movements should be shown in solid lines with the appropriate movement numbers.
- The movements within each circle should represent only those taking place within the phase.
- The connecting lines between the phase circles should be solid with arrows indicating the permitted direction of phase change.

All phase sequence diagrams are specific to the intersection and must be individually determined.

The examples in Figures 7 and 8 show three phase and multi phase diagrams for “permissive” and “protected” left-turn movements for the 170 and NEMA controllers.

In a *permissive* mode, the left-turning motorist is permitted to turn during the normal circular green display, and can complete the turn if adequate gaps occur in opposing traffic. The motorist must yield to opposing traffic and pedestrians crossing the roadway. The left-turning vehicle can clear the intersection on the normal amber indication after yielding to any opposing through vehicles and

pedestrians clearing the intersection²³.

In a *protected* mode the left-turning motorist is given a signal display that provides right-of-way over conflicting traffic. Both pedestrians and opposing traffic are prohibited from crossing the path of the left-turning vehicle during the protected left-turn movement. The protected left turn is indicated by a left arrow display.

In a *fully-protected* mode, left turning traffic is prohibited from moving other than when provided a protected left turn indication.

Permutations and combinations of different modes of left turns are possible. For example, a permissive movement may be applied to one approach and a protected movement may be applied to another within the same intersection.

In some cases, simultaneous left turns are used where left turning traffic from opposing directions are allowed to make their turn at the same time during protected left-turn movements. The simultaneous left turns are indicated by left arrow

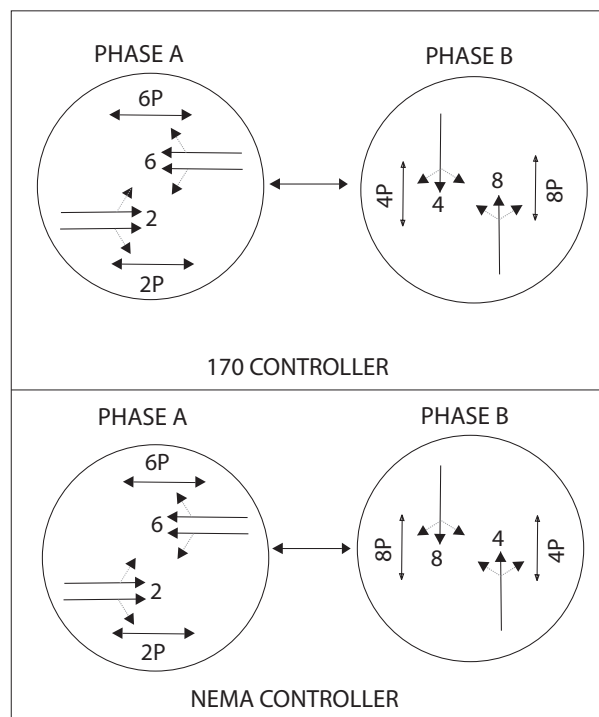

Figure 6 – Two Phase Diagram

displays facing each opposing lane of turning vehicles. For true simultaneous operation, both opposing left-turn phases start and stop at the same time. However, because it is common to apply detection to both opposing lefts, the term “simultaneous” is also used for the case where the two left-turn indications may start and end at different times.

Two Phase Operation

In a two phase operation, the controller simply alternates between main road and side road greens and can run under any mode of operation. Figure 6 shows the phase diagram.

Three Phase Operation

A three phase operation adds a left-turn signal on one approach. An example of this operation is shown in Figure 7 in which movement 5 is the advance green. Note that this operation would be classed as “protected permissive” as the left-turn green signal display shows a left-turn arrow type 8, 8A, 9 or 9A, or a flashing green arrow for the protected left-turn movement. Permissive left turns are permitted after the left-turn display has cleared.

Note that in Figure 7, the phase sequencing arrows show that the signal can not sequence from Phase B directly to Phase A, but must first pass through Phase C. (This operation ensures that a call for an advance green within Phase B does not create a trap situation.) The arrows also ensure that after serving an advance green phase, the signal must sequence to Phase B so as not to violate driver expectancy: drivers expect the parent through phases to come up after an advance green.

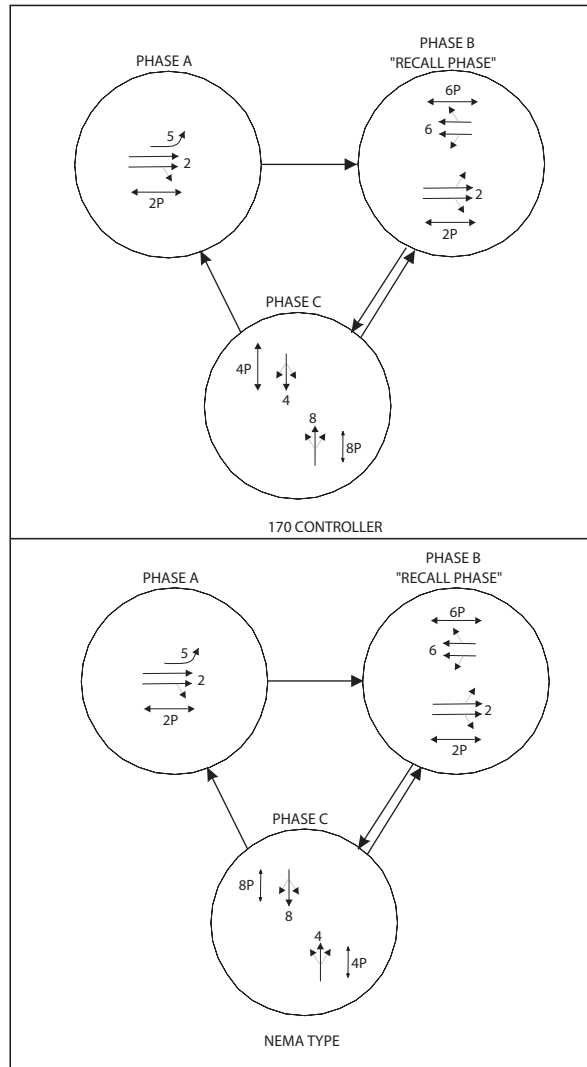

Figure 7 – Three Phase Diagram

Multiple Phase Operation

The number of phases may be increased where analysis indicates that additional phases are required to serve the traffic demands effectively.

For more complete discussions of phase diagrams and allowable phases and interval sequencing within the dual ring configurations, the engineer/analyst should consult the printed materials of the major controller manufacturers and the Ministry’s Electrical Design Manual³.

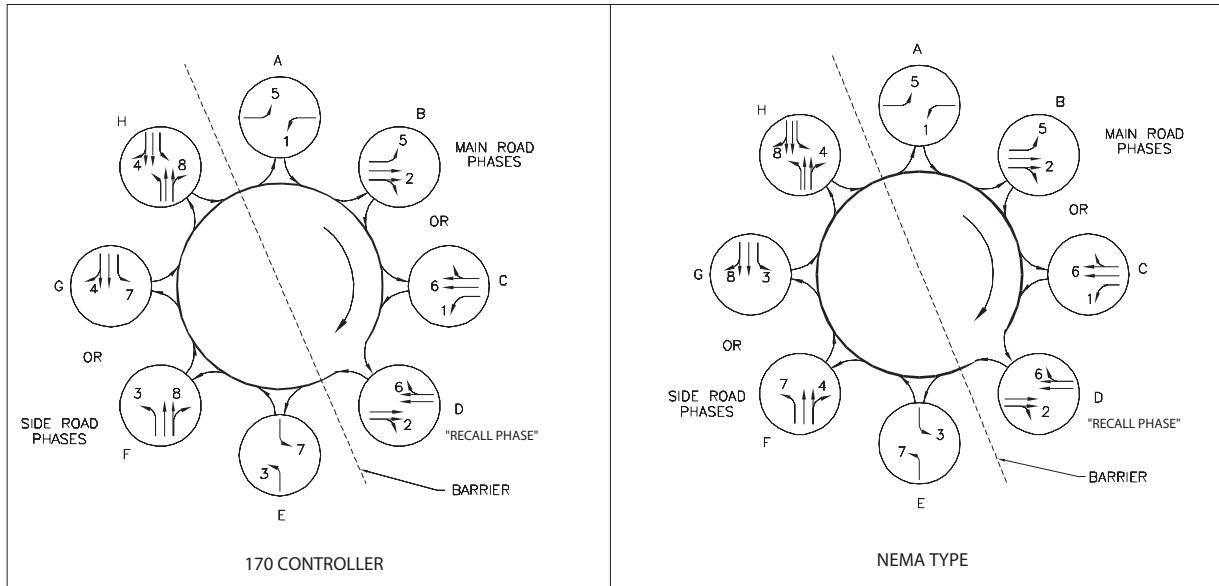

Figure 8 – Multi Phase Diagrams with Fully Protected Operation on the Main Road and Protected/Permissive Operation on the Side Road

For demonstration purposes, diagrams showing eight phase operations with protected/permissive simultaneous left turns on the side road approaches and fully protected simultaneous left turns on the main road are shown in Figure 8. The following should be noted:

- Stopped traffic is not shown.
- The operation shown will operate with a maximum of six phases per cycle since only phase 'B' or 'C' on the main road and phase 'F' or 'G' on the side road may occur in any one cycle.

Pedestrian Phases

General

Pedestrian signal indications should follow the following sequence:

- Walking Pedestrian ("Walk") shall be displayed only when the corresponding through movement green indications are displayed, or when an all-red period is displayed if special pedestrian phasing is used (such as leading pedestrian intervals or exclusive pedestrian phases). The Walking Pedestrian indication does not necessarily have to be displayed with the green at actuated intersections (where a pushbutton actuation is used) as this approach allows for the use of less vehicular green time during cycles when no pedestrians are waiting to cross.
- Flashing Hand ("Flashing Don't Walk", (FDW)) should be displayed after every Walking Pedestrian indication as this is a clearance interval required to warn pedestrians of an upcoming steady Hand Outline indication. Most agencies terminate the flashing hand at the beginning of the amber but it is permissible to continue the FDW through

the amber or all-red clearance intervals as this may provide additional information or reassurance to crossing pedestrians.

- Steady Hand Outline (“Don’t Walk”) shall be displayed with any conflicting phases. This indication may also be displayed during the amber and all-red displays.

Exclusive Pedestrian Phases

Despite the pedestrian indications discussed above, an exclusive pedestrian phase typically shows the walk indications for one or more pedestrian movements while displaying red on all traffic signal indications. Exclusive pedestrian phases are normally required only where the volumes of crossing pedestrians are extremely high and safety is impaired by the use of normal pedestrian display intervals parallel to the (vehicle) signal head. Driver confusion and undesirable delays must be carefully considered before implementing an exclusive pedestrian phase. “No Right Turn On Red” regulations implemented with this phasing may be considered to minimize conflicts and maximize pedestrian throughput.

Leading Pedestrian Phases

Another form of priority pedestrian phasing is the advance pedestrian interval where a walk indication (generally around 4 to 6 seconds in duration) is provided in advance of the corresponding vehicle green indications to give pedestrians a head start on parallel or turning traffic.

Pedestrian Signal Operation

Pedestrians facing the Walking Pedestrian indication may enter the crosswalk and proceed in the direction of the Walk display. For the pedestrian interval clearance, the Hand Outline should be a flashing indication. The clearance interval may terminate (and change to the steady Hand display) at the onset of the accompanying vehicular amber,

but in practice the clearance interval is also allowed to continue until the beginning of the all-red.

Pedestrians facing the flashing Hand Outline must not start to cross the roadway in the direction of the pedestrian signal indication. Pedestrians who have started the crossing while facing the Walking Pedestrian indication may complete their crossing and have the right-of-way over traffic to do so. Pedestrians facing the steadily illuminated Hand Outline indication must not enter the roadway.

The flashing Hand Outline should be flashed at a rate of not more than 60 nor less than 50 ON and OFF flashes per minute, with the length of each ON period approximately equal to the length of each OFF period.

Left-Turn Phase Justification

General

Left-turning movements are affected by turning volume, lane configurations, pedestrian movements, opposing traffic flow, the width of the intersection, and the phasing of the traffic control signals.

Except for the case of a protected left-turn phase, left-turning vehicles will take more time to clear the intersection than the straight through vehicles because of the opposing traffic. The left-turning vehicles may also block through vehicles unless a separate left-turn lane with adequate storage is provided.

The contents of this subsection assume that an adequate left-turn lane can be provided. If this is not the case, consideration should be given to restricting left-turning movements to one direction only or to providing a separate phase. Where shared left-through lanes are considered, and through traffic is blocked by a left turn vehicle, lane changes by through traffic must be taken into account.

Approximation

A simplified method using traffic volumes to estimate delays may be used initially to analyze the need for left-turn phases at planned or existing signalized intersections. The method is as follows.

A left-turn phase may be justified:

- i If the left-turning vehicles are not finding suitable turning gaps, volume exceeds at least two vehicles per cycle, and the Level of Service at the intersection will not be jeopardized; or
- ii If the left-turning volume plus the opposing volume > 720 vehicles per hour; or
- iii If a field check shows that vehicles consistently require more than two cycles in the queue in order to turn left; or
- iv. If an over-representation of left turning collisions is identified at the intersection

Analytical Method

Several analytical methods for determining the justification for separate left-turn phases are used in Ontario.

Ontario Capacity Analysis Method

The capacity analysis method is particularly useful for the planning of new signals.

The threshold capacity of a left-turn lane can be stated as $[1400 G/C - V_o]$ taking into account V_o , the opposing volume of traffic. This method checks to determine whether the left-turn volumes are greater than the threshold capacity required for a left-turn phase. V_o includes right-turning traffic if there is no right-turn channelization. G is the green time for the opposing flow in seconds, and C is the cycle length in seconds. If there is more than one opposing lane (not counting opposing left-turning vehicles), the left-turn lane capacity of $[1400 G/C - V_o]$ must be

Table 2 – Capacity Factor for Opposing Lanes

Number of Opposing Flow Lanes	1	2	3	4
(f) value	1.0	0.625	0.5	0.44

Source: ref. 23

modified by a factor “f” to take into account the effect of multiple opposing lanes, as given in Table 2.

The left-turning volumes normally include an allowance of two vehicles clearing the intersection per cycle by turning on the amber/all-red interval, (assuming a reasonably large intersection).

The capacity of the left-turn lane during the permissive stage (no separate left-turn phase) is given by:

$$c_{Lt} = 1400 G/C - (f) V_o + Lt_a$$

where:

c_{Lt} = the capacity of the separate left-turn lane during the permissive stage of the phase in vehicles per hour

(f) = the volume adjustment for the opposing number of lanes (Table 2)

V_o = total opposing traffic flow (vph), including through lanes, shared lanes and right-turn lanes where right-turn channelization does not exist

G/C = green time interval for the opposing flow/cycle length (seconds)

Lt_a = $7200/C$ vph and is the number of vehicles turning left on amber assuming two vehicles per cycle

If the calculated value of c_{Lt} is less than the actual number of left-turning vehicles, then a separate left-turn phase may be justified. If the

opposing and the left-turning traffic is mixed with transit buses and trucks, the volumes in the formula should be adjusted to represent passenger car equivalent volume.

Canadian Capacity Guide

The Canadian Capacity Guide¹ provides capacity evaluation techniques for left turns which consider many variables such as lane geometry, city environment, pedestrians and multiple turn lanes. It is particularly applicable if saturation flow rates have been measured for a jurisdiction, and particularly useful for understanding the effect of various factors in complex situations. The relative capacities of various options can be compared to find the phasing which best suits the left-turn demand.

Determination of the Type of Left-Turn Phase

General

Once it has been determined that a left-turn phase is required, it is necessary to assess the type of operational characteristics required. These range from the relatively simple and common protected/ permissive advanced green on one approach only (using type 8, 8A, 9 or 9A signal heads) to the complex multiple phase operation with left-turn phases in all directions. The traffic engineer/analyst must choose the type of operation and should consider the following issues:

1. If there is a geometric or visibility problem at the intersection, or if there is a historical collision pattern involving left turn vehicles, a fully protected left-turn phase should be considered.
2. Where the capacity analysis of equivalent turning volumes or queue end requirements indicates that dual left-turn lanes are required, due to equivalent left-turning volumes or because of queue length requirements, fully protected operation should be considered. Protective/permissive operation may be considered for use with dual left-turn lane operation only when:
 - The geometry of the intersection and approaches allows proper turning treatment.
 - The opposing through volumes are very low and it is considered that motorists will not have problems judging gaps in opposing traffic from the most right-hand left-turn lane.
3. Simultaneous left-turn operations should be considered wherever both opposing left-turn lanes require separate phases and the geometry of the intersection allows. The left-turn phases may be operated in the protected/permissive mode or the fully protected mode.

Recommended practice for simultaneous protected/permissive left-turn operation with single left-turn lanes uses type 8, 8A, 9 or 9A signal heads. Fully-protected left-turn operation must use separate left-turn signal heads (type 2 heads). A sign showing "Left-Turn Signal" is also required for fully protected left-turn operation. The sign should be located to the left of the median pole between the left-turn signal head and the pole, or as close to the signal head as practical and as specified in Book 5 – Regulatory Signs.
4. Delayed green or permissive/protected operation should be considered only where there is no opposing left-turn movement that could create an unsafe trap situation. The MUTCDC (B4.5.3) defines the trap as entrapment and uses the following example, "an entrapment could be created if Approach 1 rests in green and Approach 2 goes to amber. Left-turn drivers on Approach 2 would expect that vehicles on Approach 1 also have the amber indication and, therefore,

would be preparing to stop. Left-turn drivers on Approach 2 may try to use the clearance interval to cross opposing traffic which would still have a green indication on Approach 1."

Types of Left-Turn Phasing

The figures shown in this section are intended only to show the left-turn parameters. They have been adopted from the TAC MUTCD¹⁴. Additional amber, clearance and other traffic movement phases beyond those shown may be required to accommodate the local conditions of a specific intersection.

1. Protected/Permissive Single Direction Left Turn Phasing

Protected/permissive single direction left turn signal phasing (also known as "advance green" phasing) gives a protected/permissive left-turn movement in one direction. The left-turning vehicles are first given a protected interval on which to turn with the opposing traffic (including conflicting pedestrians) stopped. The associated through and right-turning vehicles are also allowed to proceed during the protected left-turn phase. After the protected left turn movement terminates with a clearance interval, the opposing traffic is released with a normal circular green ball display, allowing the left-turning vehicles to turn only after yielding to any opposing traffic.

Signal heads 8, 8A, 9, 9A, 10 or 10A may be used for protected/permissive single direction operations. The use of the amber arrow after a green left turn arrow is mandated by Regulation 626 of the HTA for simultaneous left turn operation. For single direction left turns, the use of the amber arrow is optional but should be used for consistency and to conform with TAC's requirements. While the use of either a circular flashing ball (in a Standard, Highway or Oversize Highway head) or a flashing arrow display is currently allowed under Section 144 (13)

of the HTA, the 2007 edition of this guide directed that the use of the flashing green ball should be discontinued after January 1, 2010. Jurisdictions still employing the flashing green ball display should now have plans for phasing out all such operations.

Protected/permissive, single direction, left turn phasing is shown in Figure 9.

2. Right Turn Overlap Phase

Right turn phasing may be controlled in a permissive or protected manner depending on demand, lane configuration, the presence of pedestrians, and the operation of other phases at the intersection.

Right turns may be operated in a protected mode on an overlap phase to increase efficiency at an intersection. The most typical overlap is the right turn operating at the same time as a perpendicular left turn protected phase.

Right turn overlap phasing is shown in Figure 10. The overlap right turn phase is controlled by a four section signal head, (Type 11 or 11A) in the primary position. The clearance from protected to permissive right turn is typically achieved through a short period between the end of the right turn arrow display and the beginning of the Walk display and green ball display.

Right turn overlap phasing is generally only required where there is high right turn demand through parts of the day. An exclusive right turn lane is strongly recommended for the operation of right turn overlap phasing. It should be noted that as this phasing may cause some issues for visually impaired pedestrians, the use of accessible pedestrian signals may be required to provide an audible cue to waiting pedestrians as to when to start crossing.

Right turn overlap phasing can also be implemented with back-to-back dual left turn protected permissive phasing.

3. Protected/Permissive Simultaneous Left Turn Phasing

Protected/permissive simultaneous left turn phasing gives left-turning vehicles from opposing directions a protected left-turn phase at the same time. No other conflicting vehicles or pedestrians are allowed to enter the intersection during the simultaneous protected left-turn phase. After the simultaneous protected left-turn phase has been terminated, the left-turning vehicles are permitted to turn through opposing traffic, but they must yield right-of-way.

When the left-turn lanes are separately actuated, the protected left-turn phase from one direction may terminate before the other left-turn phase. When this occurs, the associated through and right-turn vehicles, and non-conflicting pedestrians, are allowed to proceed with the one remaining protected left-turn movement. If there are no opposing left-turning vehicles during a cycle, the opposing protected left-turn phase can be skipped. In this case, the operation during that cycle will be similar to a single direction protected/permissive operation. Figure 11 shows the basic intervals.

4. Fully Protected Simultaneous Left Turn Phasing

In full protected simultaneous left turn phasing, left turns move only in a fully-protected mode. This phasing requires left-turning vehicles to be provided with their own traffic control signal heads. Left-turning vehicles from opposing directions are given a left-turn indication at the same time. No other conflicting vehicles or pedestrians are allowed to enter the intersection during the left-turn phase. In normal Ontario practice, the turn movements are usually programmed to give overlapping simultaneous lefts. The left-turn intervals are terminated with their own clearance displays, and left-turning vehicles are not permitted to proceed when the opposing through traffic is given a green indication. The opposing left turns may terminate at different times.

To help the motorist to recognize the Type 2 left-turn signal heads, a “Left Turn Signal” sign must be placed adjacent to the Type 2 heads. The fully protected simultaneous left turn operation is used where the visibility of vehicles making left turns to the opposing traffic (or vice versa) is limited, or where distractions caused by turning traffic are a concern. The operation may also be used where the opposing traffic approach has high volumes resulting in poor availability of gaps in the opposing traffic for permissive left turns. Fully protected simultaneous left turn phasing should also be used on high speed roads with potential visibility problems due to geometry, or where collision problems exist. Double left-turn lanes may also require fully protected simultaneous left turn phasing. Figure 12 shows the basic intervals.

5. Permissive/Protected Lagging Left Turn Phasing – Single Direction

For permissive/protected lagging left-turn phasing, left-turning vehicles are first permitted to turn after yielding to opposing vehicles during a normal green ball display. They are then provided with a protected left-turn phase in one direction after the opposing approach has been terminated with a circular amber and circular red display. The associated through and right-turn movements are allowed to proceed during the protected left-turn phase. **This type of phasing should only be used at locations where there is no opposing left-turn movement, for example, at “T” intersections and at 4-Leg intersections where the opposing left-turn movement is prohibited.** If used in other situations, an opposing left-turn vehicle may choose an inappropriate time to proceed while waiting for a gap as motorists generally expect the opposing traffic to receive the same signal indications (i.e., an amber display) at the same time. It is also suggested that signs be installed indicating the operation of the extended left turn. Figure 13 shows the basic intervals.

6. Separate Protected Left Turn Operation (Separate Phasing)

Separate protected left turn phasing allows one traffic approach to the intersection to proceed while the traffic on all other approaches is stopped. All movements on the separate phase approach including left turns are permitted to proceed through the intersection.

Separated protected left turn phasing is typically used to improve capacity where intersection geometrics prevent simultaneous left turns, or where there are shared lanes. This phasing may also be chosen as an effective countermeasure where a left turn with opposing through collision pattern cannot be resolved through other, less restrictive methods. Separate phasing is generally less efficient than other types of left turn phases or the standard two-phase operation, but it offers a very effective way to eliminate this specific collision type.

Figure 14 illustrates the basic intervals for separated protected left turn phasing.

7. Lagging Fully Protected Simultaneous Left Turn

The lagging fully protected simultaneous left turn is similar to the Fully Protected Simultaneous Left Turn operation described previously except that left-turn movements are given a protected phase after the through traffic phase.

Lagging fully protected simultaneous left turn phasing is seldom used, however, since left-turning displays are normally displayed before the through traffic indications. The exception occurs at intersections that are running fully actuated operation. At these locations, the fully protected left turn phase may lead or lag the through movement for any specific cycle depending on vehicle actuation.

PROTECTED/PERMISSIVE SINGLE DIRECTION LEADING LEFT-TURN PHASING

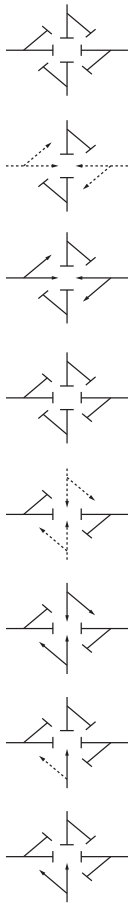

SIGNAL HEAD PLACEMENT
The minimum requirement is one primary and one secondary signal head for each approach. Auxiliary signal heads may be used as necessary.

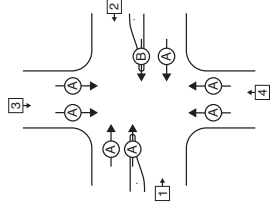

Signal head (B) should be located directly in line with the left-turn lane. It is normally mounted on a signal pole located on the median island.

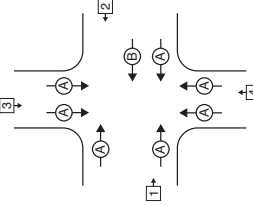

If no median island is present, this can be accomplished by using an extended mast arm, span wire, or a signal bridge that also holds the primary signal head (A) for the through/right-turn movements.

INTERVAL →	I	II	III	IV	V	VI	VII	VIII	IX
APPROACH									

NOTE: Signal head (B) can be a five-section signal head with separate amber and green arrow lenses as illustrated, or a four-section signal head with a single fibre optic green/amber arrow lens.

OPERATION:

The phasing sequence has a protected left turn on approach (1) during which all traffic on approach (1) may exclusively enter the intersection (Interval I). The protected left-turn phase is cleared through the use of an amber arrow indication (Interval II). All traffic on approaches (1) and (2) are permitted to enter the intersection (Interval III) during which time left turns on approaches (1) and (2) are permitted. Traffic on approaches (1) and (2) are cleared with an amber ball indication (Interval IV) and an all-red indication (Interval V). The standard phasing is used for approaches (3) and (4) (Intervals VI to VIII).

Figure 9 – Protected / Permissive Single Direction Leading Left-Turn Phasing (Source: TAC Figure B4-1)

PROTECTED/PERMISSIVE SINGLE DIRECTION LEADING LEFT-TURN PHASING AND RIGHT-TURN OVERLAP

SIGNAL HEAD PLACEMENT
The minimum requirement is one primary and one secondary signal head for each approach. Auxiliary signal heads may be used as necessary.

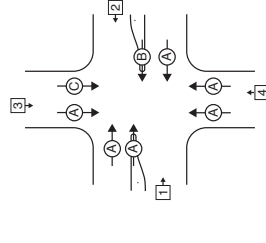

Signal head (B) should be located directly in line with the left-turn lane. It is normally mounted on a signal pole located on the median island.

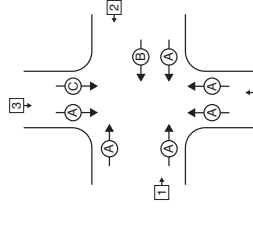

If no median island is present, this can be accomplished by using an extended mast arm, span wire, or a signal bridge that also holds the primary signal head (A) for the through/right-turn movements.

INTERVAL →	I	II	III	IV	V	VI	VII	VIII	IX

NOTE: Signal head (B) can be a five-section signal head with separate amber and green arrow lenses as illustrated, or a four-section signal head with a single fibre optic green/amber arrow lens.

OPERATION: The phasing is similar to that of Figure 9 with the addition of a protected right-turn on an overlap phase (3). The protected phase occurs simultaneously with the protected left-turn phase (1). The clearance occurs during the amber arrow display for the perpendicular street.

Figure 10 – Protected / Permissive Single Direction Leading Left-Turn Phasing and Right-Turn Overlap

PROTECTED/PERMISSIVE LEADING SIMULTANEOUS LEFT-TURN PHASING

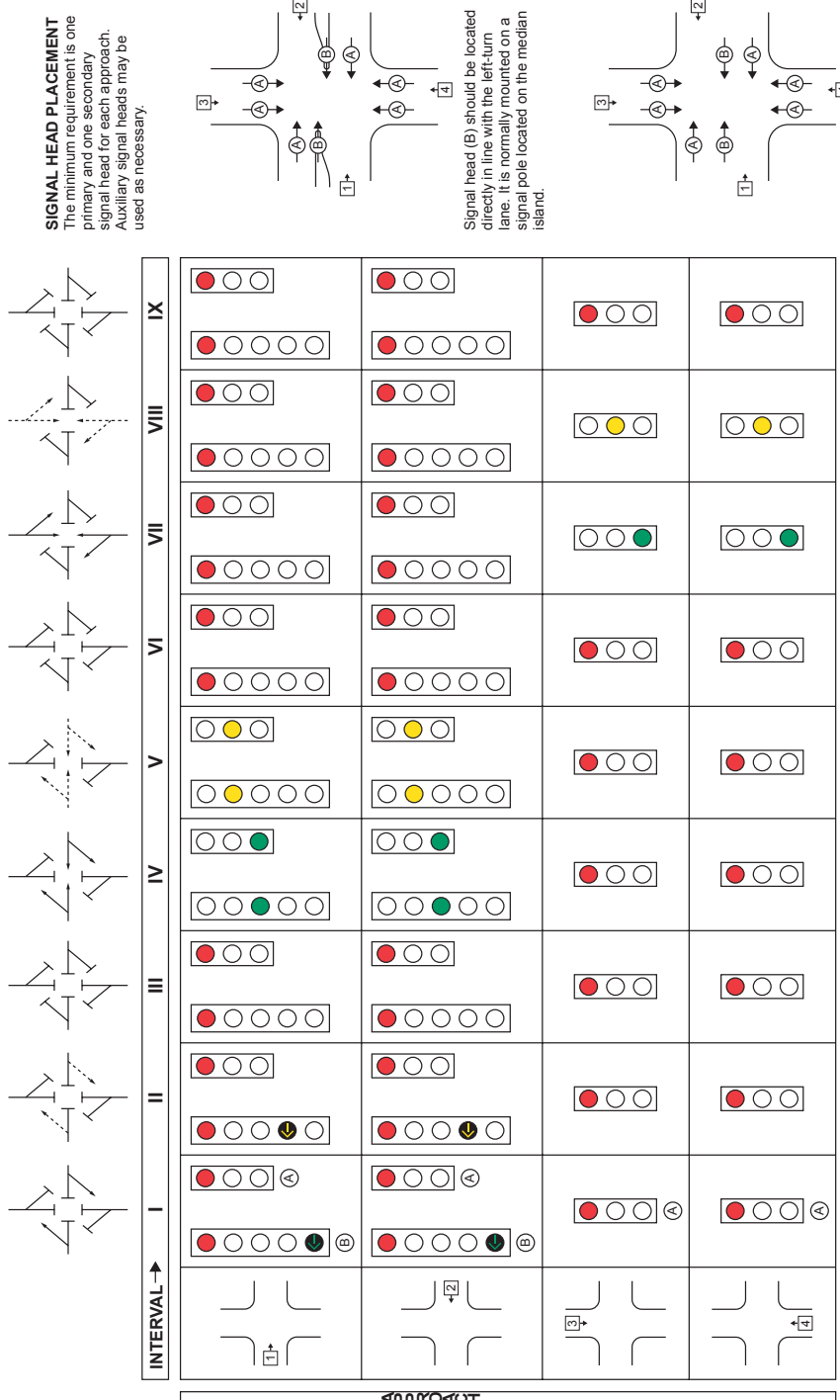

NOTE: Signal head (B) can be a five-section signal head with separate amber and green arrow lenses as illustrated, or a four-section signal head with a single fibre optic green/amber arrow lens.

OPERATION:
The phasing sequence has a protected left turn on approaches (1) and (2) during which left-turning traffic may exclusively enter the intersection simultaneously (Interval I). Each protected phase is cleared through the use of an amber arrow indication (Interval II) and an all-red interval (Interval III). All traffic on approaches (1) and (2) are permitted to enter the intersection (Interval IV) during which time left turns are allowed. Traffic on approaches (1) and (2) are cleared with an amber ball indication (Interval V) and an all-red indication (Interval VI). The standard phasing is used for approaches (3) and (4) (intervals VII to IX).

Figure 11 – Protected / Permissive Leading Simultaneous Left-Turn Phasing (Source: TAC Figure B4-2)

FULLY PROTECTED LEADING SIMULTANEOUS LEFT-TURN PHASING

INTERVAL →	I	II	III	IV	V	VI	VII	VIII	IX	

SIGNAL HEAD PLACEMENT
The minimum requirement is one primary and one secondary signal head for each approach. Auxiliary signal heads may be used as necessary.

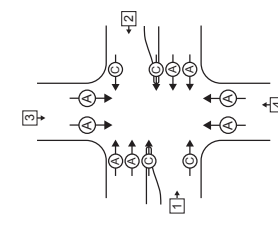

The primary left-turn signal head (C) should be located directly in line with the left-turn lane. It is normally mounted on a signal pole located on the median island.

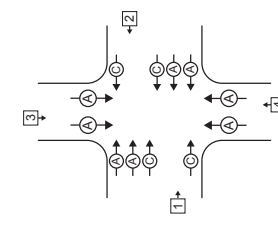

If no median island is present, this can be accomplished by using an extended mast arm, span wire, or a signal bridge that also holds the primary and secondary through/right-turn signal heads (A).

NOTE: At an actuated intersection when the left turn is called on one approach and not on the opposing approach, the controller may be programmed to display the Fully Protected Leading Left-Turn Phasing (Figure B4-7) for that approach.

OPERATION: The phasing sequence has a protected left turn during which only left-turn traffic on approaches (1) and (2) may enter the intersection (Interval I). The protected left-turn phase is cleared with an amber ball indication (Interval II) and an all-red interval (Interval III). Only through and right-turn traffic on approaches (1) and (2) may enter the intersection (Interval IV). The through and right-turn traffic is cleared with an amber ball indication (Interval V) and an all-red interval (Interval VI). The standard phasing is used for approaches (3) and (4) (Intervals VII to IX).

Figure 12 – Fully Protected Simultaneous Left-Turn Phasing (Source: TAC Figure B4-5)

PERMISSIVE / PROTECTED SIMULTANEOUS LAGGING LEFT-TURN PHASING

INTERVAL →	I	II	III	IV	V	VI	VII	VIII	IX

SIGNAL HEAD PLACEMENT
The minimum requirement is one primary and one secondary signal head for each approach. Auxiliary signal heads may be used as necessary.

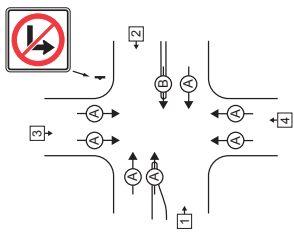

Signal head (B) should be located directly in line with the left-turn lane. It is normally mounted on a signal pole located on the median island.

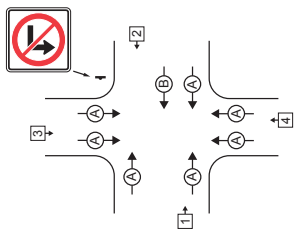

If no median island is present, this can be accomplished by using an extended mast arm, span wire, or a signal bridge that also holds the primary signal head (A) for the through/right-turn movements.

OPERATION: THIS PHASING CAN BE USED ONLY WHEN LEFT TURNS ARE NOT PERMITTED ON APPROACH (2).
All traffic on approach (1) and through and right-turning traffic on approach (2) may enter the intersection (Interval I), during which time left turns on approach (1) are permitted. The traffic on approach (2) is cleared with an amber ball indication (Interval II) and a portion of the red ball interval (Interval III). A protected left turn follows on approach (1) during which all traffic on approach (1) may exclusively enter the intersection (Interval IV). The traffic on approach (1) is cleared with an amber ball indication (Interval V) and an all-red interval (Interval VI). The standard phasing is used for approaches (3) and (4) (Intervals VII to IX).

Figure 13 – Permissive / Protected Simultaneous Lagging Left-Turn Phasing (Source: TAC Figure B4-4)

SEPARATE PROTECTED LEFT-TURN PHASING

INTERVAL →	I	II	III	IV	V	VI	VII	VIII	IX

SIGNAL HEAD PLACEMENT
The minimum requirement is one primary and one secondary signal head for each approach. Auxiliary signal heads may be used as necessary.

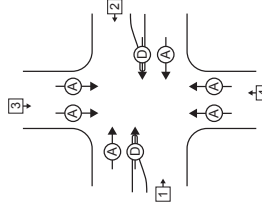

Signal head (D) should be located directly in line with the left-turn lane. It is normally mounted on a signal pole located on the median island.

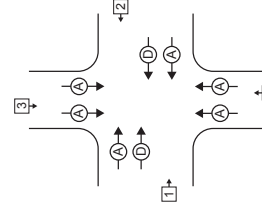

If no median island is present, this can be accomplished by using an extended mast arm, span wire, or a signal bridge that also holds the primary signal head (A) for the through/right-turn movements.

NOTE: Signal head (D) is a four-section signal head with a green arrow.

OPERATION:

The phasing sequence has a protected left turn during which all traffic only on approach (1) may enter the intersection (Interval I). The protected phase is cleared with an amber ball indication (Interval II) and an all-red interval (Interval III). A protected left turn follows, during which all traffic only on approach (2) may enter the intersection (Interval IV). The traffic on approach (2) is cleared with an amber ball indication (Interval V) and an all-red interval (Interval VI). The standard phasing is used for approaches (3) and (4) (Intervals VII to IX).

Figure 14 – Separate Protected Left-Turn Phasing (Source: TAC Figure B4-9)

3.6 Timing

General

To estimate the timing required for intervals and phases, reasonably up-to-date or predicted traffic volumes per movement are needed. Before deriving the traffic control signal timing, vehicle and pedestrian traffic flow and equivalent volumes must be analyzed. Traffic demand analysis will determine the optimum interval timing to best balance safety and traffic flow efficiency.

Guidelines are available in ITE’s “Canadian Capacity Guide for Signalized Intersections”¹ (CCG).

When determining equivalent traffic volumes (in accordance with the principles of the CCG¹), care should be taken to apply appropriate factors for turning vehicles, heavy vehicles (trucks and buses), and approach lanes. In urban conditions, the number of usable lanes may also vary at different times of the day as on-street parking, bus stops, HOV lanes, etc., may be present. The CCG uses the theory of intersection and lane flow ratios to determine minimum and optimum cycle times, capacity, delay and lost time per cycle.

However, consideration of minimum interval timing is required before the analysis of the cycle timings.

Minimum Interval Timing

Motorists do not expect a signal display that has just started to be terminated immediately¹. Minimum interval times are used to avoid this situation. Table 3 shows guidelines for minimum interval timing values.

General

The required clearance time for any through movement phase is related to the approach operating speed, motorists’ perception and reaction times, the crossing width of the intersection, and the average deceleration rate of the vehicles. Amber times are set so that motorists can reach the intersection if they are unable to stop when at the decision point for stopping or proceeding. The all-red

Table 3 – Minimum Interval Times

Interval	Preferred (seconds)	Minimum (seconds)
Circular green for roads posted at less than 80 km/h	10.0	7.0
Circular green for roads posted at 80 km/h or more	20.0 (Main Road) 10.0 (Side Road)	15.0 (Main Road) 7.0 (Side Road)
Circular amber	3.0	3.0
Protected arrow portion of protected / permissive	7.0	5.0
Clearance for protected portion of protected / permissive	3.0	2.0*
Fully protected left or right	7.0	5.0
Amber clearance for fully protected	3.0	3.0
All red	1.0	1.0
Transit priority	5.0	3.0
Pedestrian walk	7.0	5.0
Pedestrian clearance	5.0	3.0

Source: ref. 1 (in part)

* NEMA controllers are limited to 2.7 seconds minimum.

times are set so that vehicles just crossing the stop line have sufficient time to clear the intersection. It is generally accepted that the posted speed is used to ensure safe clearance times.

Amber and All-Red Clearance Intervals

The total clearance period is separated into the amber interval clearance and the all-red interval clearance. The clearance period may be expressed as:^{1, 22}

$$\text{clearance} = y+r = \text{amber} + \text{all-red} \\ = [t+V/(2a\pm 70.6g)]+[3.6(W+l)/V]$$

Where:

- y = amber interval clearance(s)
- r = all-red interval clearance (s)
- t = perception and reaction time (1 second minimum)
- V = approach posted speed (km/h)
- 70.6 = factor of 2x acceleration of gravity in km/h/s
- g = % grade/100: positive for uphill, negative for downgrade
- a = average deceleration rate (11 km/h/s is used)
- l = length of the average passenger vehicle (6.0 m is used)
- W = width of the intersecting road (m) to be crossed from the near side stop line to the far side curb line or the far outside edge of the crosswalk where used
- 3.6 = factor to convert km/h to m/s

The amber interval $[y = t + V/(2a\pm 70.6g)]$ informs the driver that the right-of-way is about to be changed and must therefore provide sufficient time for the approaching motorist to travel the stopping sight distance. The amber clearance interval in Table 4 assumes 1.0 seconds as the minimum perception-reaction time, and assumes a level approach grade. The road authority may, at its discretion and under specific conditions (typically isolated rural or high-speed locations) choose to employ a longer perception-reaction time. If this is the case, and/or if the approach grade to the intersection is significant, the amber time must be calculated directly from the formula above.

The all-red interval $[r = 3.6 (W +l)/V]$ represents the time required to provide a safe passage across the intersection for vehicles entering the intersection at or near the end of the amber interval. In the interests of standardization, an all-red interval should be used at all signalized intersections.

Clearance for Left-Turn Signals

A minimum clearance time of 2.0 to 3.0 seconds must follow the left-turn green (green arrow or fast flash green ball) before the opposing traffic is released. An all-red of 1.0 to 1.5 seconds may be used after the amber arrow if additional clearance is required.

Where the fully protected mode of operation is used in a left-turn lane, a nominal amber clearance time of 3.0 seconds should be used, followed by a 1.5 second to 2.0 second all-red to complete the clearance of any left turning vehicles left trapped in the intersection.

Table 4 – Amber Clearance Interval Times

Posted Speed (km/h)	40	50	60	70	80	90	100
Amber clearance for 1.0 seconds perception + reaction time (seconds)	3.0	3.3	3.7	4.2	4.6	5.1	5.5

Table 5 – All Red Clearance Interval Times

Clearing Distance (W + L) (m)	Posted Speed (km/h)						
	40	50	60	70	80	90	100
12.0	1.1	1.0	1.0	1.0	1.0	1.0	1.0
13.5	1.2	1.0	1.0	1.0	1.0	1.0	1.0
15.0	1.4	1.1	1.0	1.0	1.0	1.0	1.0
16.5	1.5	1.2	1.0	1.0	1.0	1.0	1.0
18.0	1.6	1.3	1.1	1.0	1.0	1.0	1.0
19.5	1.8	1.4	1.2	1.0	1.0	1.0	1.0
21.0	1.9	1.5	1.3	1.1	1.0	1.0	1.0
22.5	2.0	1.6	1.4	1.2	1.0	1.0	1.0
24.0	2.2	1.7	1.4	1.2	1.1	1.0	1.0
25.5	2.3	1.8	1.5	1.3	1.1	1.0	1.0
27.0	2.4	1.9	1.6	1.4	1.2	1.1	1.0
28.5	2.6	2.1	1.7	1.5	1.3	1.1	1.0
30.0	2.7	2.2	1.8	1.5	1.4	1.2	1.1
31.5	2.8	2.3	1.9	1.6	1.4	1.3	1.1
33.0	3.0	2.4	2.0	1.7	1.5	1.4	1.2
34.5	3.1	2.5	2.1	1.8	1.6	1.4	1.2
36.0	3.2	2.6	2.2	1.9	1.6	1.5	1.3
37.5	3.4	2.7	2.3	1.9	1.7	1.6	1.4
39.0	3.5	2.8	2.3	2.0	1.8	1.6	1.4
40.5	3.6	2.9	2.4	2.1	1.8	1.6	1.5
42.0	3.8	3.0	2.5	2.2	1.9	1.7	1.5
43.5	3.9	3.1	2.6	2.2	2.0	1.7	1.6
45.0	4.1	3.2	2.7	2.3	2.0	1.8	1.6

Notes:

1. Values do not apply to left turn clearances.
2. Where the approach to the intersection is on a significant grade, the formula used should be: $y = [t = v/(2a \pm 70.6g)]$ where $g = \% \text{ grade}/100$ and $70.6 = \text{factor } 2 \times \text{acceleration of gravity } (2 \times 3.6 \times 9.81)$ in km/h/s.
3. Three seconds is the recommended minimum for the amber clearance time. One second is the recommended minimum for the all-red.
4. If posted speeds are less than 40 km/h, 3.0 seconds for the amber and 1.0 second for the all-red are recommended.
5. W is the width of the intersection and L is the length of the typical vehicle, both in metres.

Level of Service

General

Various methods may be used to define the level of service (LOS) at an intersection (see Tables 6 and 7). While LOS A is ideal, it may not be realistic to design for this condition. LOS B or C is normally the design condition for isolated rural intersections (posted speed of 80 km/h or greater), and LOS C or D is normally the design condition for urban intersections (posted at less than 80 km/h), but it is not unusual to have LOS E in congested downtown areas or under certain specific circumstances.

The most common methods used to determine LOS are LOS Based on Delay, and LOS Based on Probability of Clearing the Arrivals.

LOS Based on Delay

The level of service for signalized intersections may be defined in terms of delay. Delay is a measure of driver discomfort and frustration, fuel consumption, and lost travel time as given in the HCM¹¹. Table 6 gives LOS for signalized intersections.

Table 6 – LOS Based on Delay

Level of service	Control Delay (s/veh)
A	≤ 10
B	> 10 - 20
C	> 20 - 35
D	> 35 - 55
E	> 55 - 80
F	> 80

Note: This table assumes Volume/Capacity Ratio of 1.0 or less. LOS is always F if Volume/Capacity Ratio is greater than 1.0.

Table 7 – LOS Based on Clearing Arrivals

Level of service	Probability of arrival vehicles clearing
A	95%
B	90%
C	75%
D	60%
E	50%

LOS Based on Probability of Clearing the Arrivals

In the LOS Based on Probability of Clearing the Arrivals, LOS is based on a probability that all vehicles arriving in the critical lane will clear the intersection in one cycle (one green interval). This method is based on average lane arrivals per cycle per critical lane. (Note that the actual arrival patterns could be different.) The probability of arrival vehicles clearing the intersection in one cycle defines the LOS, and is given in Table 7.

Determination of Green Interval Timing

General

The highest rate of traffic flow begins after approximately two to three vehicles in the same lane have started through the green signal. This is because the headway of the initial vehicles is significantly longer than the headway of vehicles further back in the queue (due to start-up lost times).

The analysis of traffic flow to determine green interval times may be accomplished by several methods. For most methodologies, there now exist software packages to assist the practitioner. The software may even include animation tools to view the operation of the simulated intersection or roadway signal group. Nonetheless, use of automated tools requires a thorough understanding

of the background concepts, principles and default constant values which support the software, before the results should be depended on. Three of the common methodologies used in Ontario are:

Canadian Capacity Guide Methodology

ITE's Canadian Capacity Guide for Signalized Intersections, 3rd Edition (CCG¹), gives a theoretical method for determining capacity based on saturation flow. In this method, Saturation Flow is defined as the rate at which vehicles that have been waiting in a queue during the red interval cross the stop line of a signalized intersection approach lane per hour of green. This method generally employs the use of arrival flows to represent travel demand for the analysis, design or evaluation of the intersection.

The guide uses lane by lane analytical techniques. The procedure requires all arrival flows and saturation flows to be expressed separately for each lane group. The critical lane group is identified by the highest flow ratio for a given phase, and is computed as the ratio of arrival flow and saturation flow. The sum of the flow ratios for the critical lanes is called the intersection flow ratio, and provides an indication of the quality of service at the intersection.

The allocation of green intervals, i.e., the duration of individual phases, normally employs the proportioning of the total available green time based on the relative values of the critical lane ratios for each phase.

Degree of saturation, capacity, probability of discharge overload, queuing and delay are measures of effectiveness used to evaluate how the intersection operates using the CCG methodology.

Software for this method is available from private sources.

Highway Capacity Manual Methodology

The principles employed in the HCM¹¹ and CCG¹ have identical theoretical foundations. The documents differ in the applications of these basic principles, in the measured values, and in the calibrated relationships that reflect specific conditions in Canada and the USA. The CCG establishes a link between the average overall delay used in the CCG and the average delay applied in the HCM for the determination of the level of service.

The Highway Capacity Manual (HCM¹¹) method uses volume to capacity ratios and average delays to measure intersection performance. Volume to capacity ratios provide a measure of sufficiency of capacity, and average delays provide a measure of the quality of service.

Capacities are determined by multiplying "Saturation Flows" by the proportion of time the movements have green during the design hour. Simply stated, saturation flow is the number of vehicles per hour that can pass through an intersection via a lane group under prevailing traffic and roadway conditions, assuming green 100% of the time. Delay is estimated from Webster's delay formula.

The HCM method takes operational objectives into account. These objectives can be used to determine green interval timing for preferred approaches using balanced delays, volume to capacity ratios, or by maximizing either measure.

The Highway Capacity Manual is available from the Transportation Research Board. Software ("HCS") is available privately.

Table 8 – Rural Intersections: Arrival Rates for Various Levels of Service

Level of Service					"X" VEHICLES	GREEN plus AMBER (SEC)
A (95%)	B (90%)	C (75%)	D (60%)	E (50%)		
0.0 - 0.3	0.2 - 0.5	0.3 - 0.9	0.5 - 1.3	0.7 - 1.6	1	3.8
0.4 - 0.8	0.6 - 1.1	1.0 - 1.7	1.4 - 2.2	1.7 - 2.6	2	7.0
0.9 - 1.3	1.2 - 1.7	1.8 - 2.5	2.3 - 3.1	2.7 - 3.6	3	9.7
1.4 - 1.9	1.8 - 2.4	2.6 - 3.3	3.2 - 4.0	3.7 - 4.6	4	12.0
2.0 - 2.8	2.5 - 3.1	3.4 - 4.2	4.1 - 5.0	4.7 - 5.6	5	14.2
2.9 - 3.2	3.2 - 3.8	4.3 - 5.0	5.1 - 6.0	5.7 - 6.6	6	16.4
3.3 - 3.9	3.9 - 4.6	5.1 - 5.9	6.1 - 6.9	6.7 - 7.6	7	18.6
4.0 - 4.6	4.7 - 5.4	6.0 - 6.8	7.0 - 7.9	7.7 - 8.6	8	20.8
4.7 - 5.4	5.5 - 6.2	6.9 - 7.7	8.0 - 8.8	8.7 - 9.6	9	23.0
5.5 - 6.1	6.3 - 7.0	7.8 - 8.6	8.9 - 9.8	9.7 - 10.6	10	25.1
6.2 - 6.9	7.1 - 7.8	8.7 - 9.5	9.9 - 10.8	10.7 - 11.6	11	27.2
7.0 - 7.7	7.9 - 8.6	9.6 - 10.4	10.9 - 11.7	11.7 - 12.6	12	29.3
7.8 - 8.4	8.7 - 9.4	10.5 - 11.3	11.8 - 12.7	12.7 - 13.6	13	31.4
8.5 - 9.2	9.5 - 10.3	11.4 - 12.2	12.8 - 13.7	13.7 - 14.6	14	33.5
9.3 - 10.0	10.4 - 11.1	12.3 - 13.1	13.8 - 14.6	14.7 - 15.6	15	35.6
10.1 - 10.8	11.2 - 11.9	13.2 - 14.0	14.7 - 15.6	15.7 - 16.6	16	37.7
10.9 - 11.6	12.0 - 12.8	14.1 - 14.9	15.7 - 16.6	16.7 - 17.6	17	39.8
11.7 - 12.4	12.9 - 13.6	15.0 - 15.9	16.7 - 17.6	17.7 - 18.6	18	41.9
12.5 - 13.2	13.7 - 14.5	16.0 - 16.9	17.7 - 18.5	18.7 - 19.6	19	44.0
13.3 - 14.0	14.6 - 15.3	17.0 - 17.8	18.6 - 19.5	19.7 - 20.6	20	46.0
14.1 - 14.9	15.4 - 16.2	17.9 - 18.7	19.6 - 20.5	20.7 - 21.6	21	48.0
15.0 - 15.7	16.3 - 17.0	18.8 - 19.6	20.6 - 21.5	21.7 - 22.6	22	50.0
15.8 - 16.5	17.1 - 17.9	19.7 - 20.5	21.6 - 22.4	22.7 - 23.6	23	52.0
16.6 - 17.4	18.0 - 18.8	20.6 - 21.4	22.5 - 23.4	23.7 - 24.6	24	54.0
17.5 - 18.2	18.9 - 19.7	21.5 - 22.4	23.5 - 24.4	24.7 - 25.6	25	56.0
18.3 - 19.0	19.8 - 20.6	22.5 - 23.3	24.5 - 25.4	25.7 - 26.6	26	58.0
19.1 - 19.9	20.7 - 21.5	23.4 - 24.3	25.5 - 26.3	26.7 - 27.6	27	60.0
20.0 - 20.7	21.6 - 22.3	24.4 - 25.2	26.4 - 27.3	27.7 - 28.6	28	62.0
20.8 - 21.6	22.4 - 23.2	25.3 - 26.2	27.4 - 28.3	28.7 - 29.6	29	64.0
21.7 - 22.4	23.3 - 24.1	26.3 - 27.1	28.4 - 29.3	29.7 - 30.6	30	66.0
22.5 - 23.3	24.2 - 25.0	27.2 - 28.0	29.4 - 30.3	30.7 - 31.6	31	68.0
23.4 - 24.2	25.1 - 25.9	28.1 - 29.0	30.4 - 31.2	31.7 - 32.6	32	70.0
24.3 - 25.1	26.0 - 26.8	29.1 - 29.9	31.3 - 32.2	32.7 - 33.6	33	72.0
25.2 - 25.9	26.9 - 27.6	30.0 - 30.9	32.3 - 33.2	33.7 - 34.6	34	74.0
26.0 - 26.7	27.7 - 28.5	31.0 - 31.8	33.3 - 34.2	34.7 - 35.6	35	76.0

- Notes: (1) The relationship between the average and maximum arrival rates is based on the Poisson Distribution.
- (2) The relationship between arrival rates and phase times is based on the Greenshield's Chart of Headways for passenger (car) vehicles.⁶
- (3) Each truck or bus is equivalent to 2.0 passenger cars.
- (4) The percentages for each column are the probabilities of a vehicle clearing the intersection on the first green.
- (5) "X" vehicles are the average flow at LOS E for the associated green plus amber time.
- (6) The shaded area falls below the minimum through movement timing requirements.

Table 9 – Urban Intersections: Arrival Rates for Various Levels of Service

Level of Service					"X" VEHICLES	GREEN plus AMBER (SEC)
A (95%)	B (90%)	C (75%)	D (60%)	E (50%)		
0.0 - 0.3	0.2 - 0.5	0.3 - 0.9	0.5 - 1.3	0.7 - 1.6	1	2.6
0.4 - 0.8	0.6 - 1.1	1.0 - 1.7	1.4 - 2.2	1.7 - 2.6	2	4.9
0.9 - 1.3	1.2 - 1.7	1.8 - 2.5	2.3 - 3.1	2.7 - 3.6	3	7.0
1.4 - 1.9	1.8 - 2.4	2.6 - 3.3	3.2 - 4.0	3.7 - 4.6	4	8.9
2.0 - 2.8	2.5 - 3.1	3.4 - 4.2	4.1 - 5.0	4.7 - 5.6	5	10.8
2.9 - 3.2	3.2 - 3.8	4.3 - 5.0	5.1 - 6.0	5.7 - 6.6	6	12.7
3.3 - 3.9	3.9 - 4.6	5.1 - 5.9	6.1 - 6.9	6.7 - 7.6	7	14.6
4.0 - 4.6	4.7 - 5.4	6.0 - 6.8	7.0 - 7.9	7.7 - 8.6	8	16.5
4.7 - 5.4	5.5 - 6.2	6.9 - 7.7	8.0 - 8.8	8.7 - 9.6	9	18.4
5.5 - 6.1	6.3 - 7.0	7.8 - 8.6	8.9 - 9.8	9.7 - 10.6	10	20.2
6.2 - 6.9	7.1 - 7.8	8.7 - 9.5	9.9 - 10.8	10.7 - 11.6	11	22.0
7.0 - 7.7	7.9 - 8.6	9.6 - 10.4	10.9 - 11.7	11.7 - 12.6	12	23.8
7.8 - 8.4	8.7 - 9.4	10.5 - 11.3	11.8 - 12.7	12.7 - 13.6	13	25.6
8.5 - 9.2	9.5 - 10.3	11.4 - 12.2	12.8 - 13.7	13.7 - 14.6	14	27.4
9.3 - 10.0	10.4 - 11.1	12.3 - 13.1	13.8 - 14.6	14.7 - 15.6	15	29.2
10.1 - 10.8	11.2 - 11.9	13.2 - 14.0	14.7 - 15.6	15.7 - 16.6	16	31.0
10.9 - 11.6	12.0 - 12.8	14.1 - 14.9	15.7 - 16.6	16.7 - 17.6	17	32.8
11.7 - 12.4	12.9 - 13.6	15.0 - 15.9	16.7 - 17.6	17.7 - 18.6	18	34.6
12.5 - 13.2	13.7 - 14.5	16.0 - 16.9	17.7 - 18.5	18.7 - 19.6	19	36.4
13.3 - 14.0	14.6 - 15.3	17.0 - 17.8	18.6 - 19.5	19.7 - 20.6	20	38.2
14.1 - 14.9	15.4 - 16.2	17.9 - 18.7	19.6 - 20.5	20.7 - 21.6	21	40.0
15.0 - 15.7	16.3 - 17.0	18.8 - 19.6	20.6 - 21.5	21.7 - 22.6	22	41.8
15.8 - 16.5	17.1 - 17.9	19.7 - 20.5	21.6 - 22.4	22.7 - 23.6	23	43.7
16.6 - 17.4	18.0 - 18.8	20.6 - 21.4	22.5 - 23.4	23.7 - 24.6	24	45.6
17.5 - 18.2	18.9 - 19.7	21.5 - 22.4	23.5 - 24.4	24.7 - 25.6	25	47.5
18.3 - 19.0	19.8 - 20.6	22.5 - 23.3	24.5 - 25.4	25.7 - 26.6	26	49.4
19.1 - 19.9	20.7 - 21.5	23.4 - 24.3	25.5 - 26.3	26.7 - 27.6	27	51.3
20.0 - 20.7	21.6 - 22.3	24.4 - 25.2	26.4 - 27.3	27.7 - 28.6	28	53.2
20.8 - 21.6	22.4 - 23.2	25.3 - 26.2	27.4 - 28.3	28.7 - 29.6	29	55.1
21.7 - 22.4	23.3 - 24.1	26.3 - 27.1	28.4 - 29.3	29.7 - 30.6	30	57.0
22.5 - 23.3	24.2 - 25.0	27.2 - 28.0	29.4 - 30.3	30.7 - 31.6	31	58.9
23.4 - 24.2	25.1 - 25.9	28.1 - 29.0	30.4 - 31.2	31.7 - 32.6	32	60.8
24.3 - 25.1	26.0 - 26.8	29.1 - 29.9	31.3 - 32.2	32.7 - 33.6	33	62.7
25.2 - 25.9	26.9 - 27.6	30.0 - 30.9	32.3 - 33.2	33.7 - 34.6	34	64.6
26.0 - 26.7	27.7 - 28.5	31.0 - 31.8	33.3 - 34.2	34.7 - 35.6	35	66.5

- Notes: (1) The relationship between the average and maximum arrival rates is based on the Poisson Distribution.
- (2) The relationship between arrival rates and phase times is based on Ministry of Transportation of Ontario Time to Enter Studies (1986 to 1988).
- (3) Each truck or bus is equivalent to 2.0 passenger cars.
- (4) The percentages for each column are the probabilities of a vehicle clearing the intersection on the first green.
- (5) "X" vehicles are the average flow at LOS E for the associated green plus amber time.
- (6) The shaded area falls below the minimum through movement timing requirements.

Ministry of Transportation Methodology

The Ministry of Transportation, Ontario (MTO) methodology for calculating required green times employs the Poisson random probability function.

The Poisson random probability function is based on the concept that vehicles arriving at a signalized intersection will, to a certain degree of probability, be able to clear the intersection during the first green interval encountered upon their arrival. The Poisson distribution is used because it has been found to give a reasonably good simulation of actual traffic conditions at signalized intersections.

The level of service is used to describe the quality of traffic flow under various operating and geometric conditions. The degree of probability of the vehicles clearing the intersection determines the level of service. Five levels of service are used in this method, each with a different degree of probability of clearing the intersection during the first green interval. To determine the length of a green interval for a through phase, it is necessary to identify the critical movement for the phase. The critical movement is the movement with the highest average equivalent volume per lane, V_{Le} , or average arrival rate per lane, m . Using the average arrival rate (m) for the critical movement at a specified LOS, the green plus amber time for the phase is obtained.

The average arrival rate (m) is determined as the total number of vehicles per hour arriving at the intersection divided by the number of signal cycles per hour. Lookup tables (Tables 8 and 9) have been developed for both rural and urban commuter environments. The tables show the relationship between average arrivals for each clearance probability (level of service) and the time required for successive vehicles to enter the intersection upon the start of the green interval. For a desired level of service and calculated average arrival rate, the corresponding green plus amber time can be found in the lookup table.

Calculation of Initial Green and Green Extension Time for Actuated Control

Where actuation of an individual intersection is used, the green interval timing may be set to a fixed initial portion plus a variable extendible portion. The extendible portion consists of a series of green extensions. The number of extensions called depends on the traffic demands on that phase. The green interval time may be extended up to a set maximum value. The minimum time for the green interval is the fixed initial portion plus one unit of extension. The initial portion green interval should be calculated to clear all vehicles which could queue between the stop line and the detector closest to the intersection. The actual timing setting would be the calculated minimum green minus one vehicle extension time unit. A unit extension is typically the time allowed for vehicles moving at average speed to travel from the detectors to within one second of the stopline. In some systems, the unit extension time should be based on holding the phase green to service an approaching vehicle while demand for the conflicting flow is present. Longer extension times should be considered for approaches with high volumes of heavy vehicles.

Vehicle actuations during the initial portion have no effect on interval timing, but each succeeding vehicle actuation during the extendible portion cancels the previous unit extension and starts a new extension timer. The green interval is extended as long as vehicle actuations are spaced closer than the extension times, unless terminated by a "maxout".

Determination of Delays On Actuation

Where actuation of an approach or phase is used, a delay in the registration of a vehicular actuation at the controller may be set for the detectors. This delay is commonly used for vehicles that stop at the detection device, but are turning when a gap is

available in conflicting traffic. Delays may be set for either right turns or left turns.

The right turn delay time is typically based on allowing a reasonable opportunity for a right turn on red, and is normally set between 5 and 12 seconds. If the waiting vehicle does not clear the detection device within this period, a call will be placed in the controller to service the phase.

Left turn delays are more typically based on the possibility that a perpendicularly travelling vehicle will cut the corner and will momentarily travel over the edge of the left turn loop, sending a false call for service. The left turn loop delay is typically 1 to 3 seconds, and may have to be determined through site observation after the intersection is installed.

Calculation Of Pedestrian Timing

General

Where pedestrians are present at signalized intersections, the minimum safe crossing needs should be accommodated in the times provided for the pedestrian interval (“Walk”) and the pedestrian clearance interval (“Flashing Don’t Walk” and “Solid Don’t Walk” through the amber and/or all-red intervals). Pedestrian timings must be generous enough to ensure that pedestrians are given enough time to cross safely and comfortably, but not so over-generous that service to vehicular traffic is unduly compromised.

The pedestrian clearance interval, or “Flashing Don’t Walk” (FDW), is generally calculated to include the amber and all-red intervals. However, the FDW may be displayed up to the amber, through the amber, or through the amber/all-red intervals. The advantage of displaying the FDW during the amber or amber/all-red clearance interval times is that it gives pedestrians reassurance that they still have the right to be in the intersection during the vehicle clearance. A disadvantage of this approach is the

potential conflicts between pedestrians still in the crosswalk and turning vehicles trying to clear the intersection.

The FDW should not be less than 5.0 seconds duration except in exceptional circumstances such as a crossing on a very narrow (two lane) roadway with low posted speeds. Here, the pedestrian clearance interval may be reduced to a minimum of 3.0 seconds provided that the pedestrian clearance interval terminates upon activation of the vehicular amber interval.

When the sum of the vehicle green and amber (and optionally all red) clearance times are in total greater than the minimum total pedestrian Walk and pedestrian clearance intervals, the difference should be added to the Walk time. When the pedestrian Walk plus clearance interval times are greater than the required vehicle phase time, the pedestrian values shall overrule the required vehicular values, and the vehicle phase shall be extended to at least match the minimum required pedestrian total interval times.

The walking speed of pedestrians (W_s) normally varies between 1.0 m/s and 1.25 m/s. A normal walking speed of 1.2 m/s is usually assumed for initial calculations although a speed of 1.0 m/s may be used at crossings frequented by young children, seniors, and special needs persons. The timing can be field adjusted for such conditions. However, on wide arterials, the total pedestrian time normally governs the time available for the non-coordinated phases, and may impact the minimum cycle time.

The pedestrian crossing distance, W_c , may be taken as the longest distance within the crosswalk measured from the point of stepping onto the pavement to the point of non-conflict with any traffic or as the distance from curb to curb along the centreline of the crosswalk.

The minimum Walk time (as per Table 3) should be observed. The pedestrian clearance interval should be equal to W_c/W_s .

As a result of prevailing local conditions, pedestrian timing methods may vary from the above approach, and may vary among road authorities (as implemented by experienced and knowledgeable practitioners). The key point is the need to maintain consistency and not violate pedestrian expectancy.

Pedestrian Actuation

When the minimum vehicle green interval is less than the sum of the minimum pedestrian crossing time and the pedestrian clearance time (for vehicles at intersections with traffic actuated controls), and a pedestrian actuation is detected, the green vehicle time must be extended.

In most operations, the pedestrian pushbutton actuation is accepted as a call during all times except when the Walking Pedestrian indication is already underway.

Determination of Cycle Length

Guidelines

The calculation and selection of cycle lengths requires an estimation of the “lost capacity” per phase due to start-up headways and the effects of cycle length on vehicle delay. The calculation and selection of cycle lengths also requires good judgement on the part of the traffic engineer/analyst.

Guidelines for cycle length selection are as follows²²:

- The useful range for cycle lengths is between 50 and 120 seconds for 2- or 3-phase operation.
- Where roadways are wide (over 15 m), with long pedestrian walk times (over 20 seconds), or where heavy traffic is present, or turning interference is significant, a cycle length of 60 to 90 seconds is required to serve minimum timing requirements.
- Where three or four phases are present, a cycle length of 90 to 120 seconds is generally preferred.
- For capacity calculations, a cycle length of 90 seconds is usually considered optimum since lost time is approaching a minimum, capacity is approaching a maximum, and delay is not too great.
- Intersection capacity drops substantially when cycle lengths fall below 60 seconds (a greater percentage of available time is used by the clearance intervals).
- The impact of cycle length on pedestrian and side road delays and on side road and left-turn queue lengths should be considered in the selection of cycle length.
- There are only minimal increases in capacity when cycle lengths rise above 100 seconds. As any through green interval approaches 45 seconds duration, there is a decrease in saturated flow so that fewer vehicles per lane per second traverse the intersection.
- In many situations, the pedestrian timing required (walk interval plus pedestrian clearance interval) will be greater than the green interval time required for traffic. This is particularly true for side road timing as the pedestrians must cross the wider main road, and at intersections where it is necessary to adjust walk time for the accommodation of seniors, young children, and/or special needs persons. In such cases, the pedestrian timing will overrule the green interval timing, and the green indication will be on, but not efficiently serving vehicular traffic.

- Analysis and evaluation should consider optimization of the cycle length (to the nearest second) to obtain minimal delays to vehicles and pedestrians, and to provide sufficient capacity to accommodate the highest LOS possible. Starting the analysis with a 90 second cycle length is suggested.

Cycle Composition

Cycle length calculations require consideration of the following points:

- Amber and all-red clearance times are fixed by the speed of the traffic and the width of the intersection and they should be added together to give the “intergreen”¹ times or the “lost times”.
- Where interconnected or central systems are operating, it is preferable to use a cycle length that fits in with other surrounding intersections and allows for coordinated operations.
- Hourly, daily and weekly traffic variations should be examined to determine when different timing plans are required. It is not uncommon to use different phase timing and different cycle lengths to accommodate the variations in flows and directions at different times of day, week or season.
- Protected left-turn phases should be considered where demand and safety dictates. However, the use of left-turn phases should be considered against a decline in progression, a degradation in the opposing level of service and the possibility of not being able to fit the turn phase timing into the existing cycle length at a signal operating in a coordinated system on a predetermined background cycle.

Many worked examples may be found in ITE’s “Canadian Capacity Guide for Signalized Intersections”¹ (CCG).

3.7 Signal Spacing

New Signalized Intersections

Where a new “interstitial” intersection is planned, the distance between signalized intersections should be reviewed taking into account the following:

- A coordinated system should be considered for local or central system operation where intersections are less than 1.0 km apart for posted speeds less than 80 km/h and less than 1.5 km apart for posted speeds of 80 km/h and over.
- Given that left turn storage lanes do not usually exceed 85 m in length for low LOS, the minimum distance between intersections is approximately 215 m for roads posted at 60 km/h or less and up to 350 m for roads posted at 80 km/h. These minimum distances are designed to allow “back-to-back” left turn lanes and proper tapers (but do not consider optimal coordination).
- A distance of 215 m between signalized intersections will usually be sufficient to allow motorists to recognize and react to each device (but this distance does not consider optimal coordination).
- Intersection spacing that is less than 415 m or greater than 625 m may affect progression efficiency at a posted speed of 50 km/h.
- Any new intersection will produce delays to traffic flow. Traffic analysis should consider the pattern that routinely occurs at traffic signals: deceleration, decreasing headways, stopping, accelerating, and increasing

headways. Repeating this pattern at the new intersection may produce unacceptable delays and poorer levels of service. ITE's "Canadian Capacity Guide for Signalized Intersections"¹ (CCG) gives analysis methods for determining whether continuous queues will exist and whether delays are to be expected.

- Signal spacing should include a progression analysis to ensure that proper coordination of the signals is possible for a range of traffic demands.

3.8 Flashing Operation

Advanced Green Flashing Green Ball and Flashing Arrow Operation

In Ontario, the circular flashing green indication has been used to provide a separate advanced left turn phase for a single approach at an intersection when protected/permissive green is necessary in a single direction only. Ontario is one of only a few users of the circular flashing advanced green in North America, and its use may cause some confusion for out-of-province motorists. Consequently, the use of the circular flashing advanced green was deemed to be no longer permitted in Ontario after **January 1, 2010**. At the time of publication of this version of Book 12, all jurisdictions should have phased out the flashing green ball displays or have plans to do so. During the phase out period, it is strongly recommended that a flashing green arrow not be used in the proximity of intersections with circular flashing advanced greens since drivers may be confused by the different methods.

The national standards, as given in the TAC MUTCD¹⁴, recognize flashing arrow signal displays only, and do not recognize steady arrow or flashing circular displays. The use of the flashing advanced green arrow is at the discretion of the road authority. If the flashing green arrow is used, it is

recommended that it is used only in an area which does not have any circular flashing advance greens. In areas where circular flashing advanced greens were predominant, it is suggested that the process should be to reconstruct the circular flashing advance greens to steady arrow control. This process should be followed by a separate process to introduce flashing arrows.

Standardized Flashing Amber and Red Operation

Traffic control signals may be switched from their normal cycling operation to flashing operation. Three modes of flashing operation are normally used:

- Start-up flash – the signals are commonly started with flashing ambers on the main road and flashing reds on the side roads.
- Emergency flash – when a conflict is detected, the signals are commonly flashed in an all-red or "red-red" mode if the controller flashers have that capability. The red-red mode has a safety advantage over the red-amber mode (reds on side road; ambers on main roads). However, the red-amber mode is an acceptable alternative and is considered preferable on roads with posted speeds of 80 km/h and above with light side road traffic as fewer stops are required.
- Timed flash – the signals may be programmed to operate in the red-red or red-amber mode during various periods of the night, week or season, for special events, or during a police over-ride mode of operation.

It should be noted that flashing operations within a traffic control signal cabinet are generally wired as either red-red or amber-red and the flash circuit cannot be changed from one mode to another without re-wiring the necessary circuits.

Planned flashing operation for signalized intersections may be advantageous to traffic flow

under some specific and limited conditions. Flashing operation may help to reduce vehicle delay and stops in pretimed networks at locations with poor signal spacing. Planned flashing is only applicable under conditions of very light minor street traffic such as during the overnight period, or in locations that have extended periods of low volume such as accesses to an industrial area. Caution should be used in the application of planned flashing signal operation. It should only be used if:

- Sidestreet traffic is very light (less than 200 vph combined for both directions).
- The traffic signals operate fixed time (i.e., no side street vehicular or pedestrian actuation).
- The planned flash mode is amber flash for the main street and red flash for the side street.
- There is no emergency vehicle pre-emption capability.
- Pedestrian volumes crossing the main street during planned flashing period are very light.
- The major roadway is not channelized and has no more than four lanes.

If planned signal flash is implemented, regular safety reviews should be conducted to compare the occurrence of collisions during the flash hours at intersections with planned flash with similar locations without planned flash.

The standard flashing red or flashing amber traffic control signal indication shall be at a rate of not more than 60 and not less than 50 ON and OFF flashes per minute, with the length of each ON period approximately equal to the length of each OFF period. The flash rate is slower than that used for flashing advance green or protected/permissive indications.

3.9 Preemption and Priority

General

All modern controllers offer both preemption and priority operations in addition to signal plans. Preemption involves an interruption in the timing or phasing operations of the traffic signal. Priority operations allow for phasing and timing changes (generally within the active cycle time) that do not require the controller to interrupt the operations of the timing plan.

Most modern controllers have two preemption modes of operation: one for railway plans (two plans) and one for emergency vehicle plans (two to four plans). The preemption mode allows a limited operation where one or more phases remain on red and one or more phases remain on green until the pre-emption event is terminated. The preemption may be activated by one of the following events:

- An approaching train is detected on a level crossing that crosses one or two of the roadways near or within an intersection.
- An approaching emergency fire vehicle is detected on the approach. This causes the signal to return to green for that approach as soon as possible, and/or to hold the green on the vehicle's approach.
- A manual actuation is received, most typically from a fire station close to a signalized intersection.

Transit priority is the most common and widely used form of traffic signal priority operations in Ontario. Upon detection of an approaching transit vehicle, a traffic signal controller may respond in the following ways: it may invoke timing changes such as an early green or green extension, or it may invoke phasing changes such as servicing an actuated priority phase, inserting a phase into the cycle, or rotating the phases within the cycle.

Different manufacturers of traffic control equipment execute preemption and priority in slightly different ways. Many modern day controllers are capable of providing these functions directly, while in other situations, the functions are provided from a master controller or a central system.

Preemption For Railway Crossings

Where a proposed traffic control signal installation is close to a railway crossing, the traffic control signal installation should be discussed with the appropriate railway authority. The installation must operate in a way that reflects Transport Canada guidelines.

Where the railway crossing actually lies within the intersection itself, special treatment of railway and highway signals will be required to provide greater protection for vehicles. Examples of this are given in the MUTCDC¹⁴.

In the case of railway preemption, it is extremely important that a preemption sequence compatible with the railway crossing signals provides for safe vehicle, pedestrian and train movements. Because trains cannot stop in time to accommodate traffic at the level crossing, it is essential that the separate intersection and railway signal devices complement rather than conflict with each other¹⁹.

The following situations may require railway preemption phases and the interconnection of railway and vehicle signals:

1. Where a railway crossing is in proximity to an intersection such that vehicles queue towards the tracks, and inadvertent vehicular stoppage may occur on the level crossing, it will be necessary to provide a preemption phase to clear the approach before the train arrival. This situation requires analysis of the time required to clear the tracks during the preemption phase (plus a suitable factor of safety).
2. Similarly, a railway crossing may be close to the intersection, and the activation of the railway crossing control gates may cause vehicles to queue back into the intersection, essentially plugging up the distance between the intersection and the railway tracks. In these cases, railway preemption can help to prevent the intersection from becoming blocked.
3. Where a railway crossing may be close to the intersection, it is also necessary to disallow turns into the roadway with the railway crossing while the crossing is active. This may be accomplished by eliminating a phase, by activating arrow signal heads, by activating blank-out signs, or some combination of these options.

The ITE's "Preemption of Traffic Signals At or Near Railroad Grade Crossings with Active Warning Devices"¹⁹ provides recommendations on when to include preemption operations, and some recommended design considerations.

Signals that require railway interconnection should not be constructed until the approval of the appropriate railway authority (and Transport Canada) has been received. In some instances, this process can take many months to complete.

Preemption For Emergency Vehicles

Preemption for emergency vehicles can be activated through systems that use dedicated short range communications (DSRC). Preemption for a small number of intersections close to a station can similarly be activated by simple devices such as a pushbutton inside the station. Preemption can be used locally to allow traffic control signals at or near the station entrance to remain on green until the emergency vehicles have left allowing easier passage through nearby intersections. The activation is similar to the action of a detector sensor amplifier and puts in a call for the preemption phase to begin

after suitable minimum interval times and clearance times have been met. In the case of centralized systems, once the initial call is made, a moving window form of preemption can be implemented.

Either type of preemption system normally requires an investigation of the intersections or arterials to be managed and of the vehicles to be fitted. Other factors include a review of the impacts of coordination and the capabilities of the existing equipment, and an agreement on cost sharing for the involved parties.

3.10 Miscellaneous Signals

Pedestrian Signals

Traffic control signal systems intended to serve only pedestrian traffic may be installed at appropriate pedestrian crossing locations. The locations may be at intersections (Intersection Pedestrian Signals (IPS)) or between intersections (Midblock Pedestrian Signals (MPS)). Both types require the main road traffic to be fully signalized.

At IPS locations, the side road must be controlled with stop signs. The control of the pedestrian signals is by pedestrian actuated two phase operation with pedestrian signal indications used for crossing the main street and regular traffic control signals used on the main roadway approaches. No pedestrian signals are used on the main road.

Pedestrian timing should be set as for normal intersections, and should consider the factors discussed in Subsection 3.5. The controller should rest in main road green until a pedestrian actuation is received. The controller may operate in conjunction with the background cycle imposed by a system, but system control may often be at odds with the purpose of the pedestrian signal, which is installed to provide a high level of service and quick response to waiting pedestrians. The

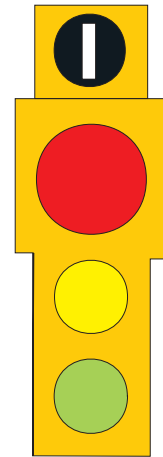

Figure 15 – Transit Priority Signal

controller timings should have a minimum green interval programmed for the main road so that an acceptable level of service for main street vehicular traffic can be maintained in the event of continual pedestrian actuations.

Transit Priority Signals

A transit priority signal display (see Figure 15) may be used to assign right-of-way to public transit vehicles over all other vehicular and pedestrian traffic movements within a signalized intersection. The transit priority signal may be operated exclusively during a protected transit movement or concurrently with other non-conflicting vehicular movements.

Transit priority signals can be used on the primary traffic signal head or on the secondary traffic signal head or on both, depending on the transit movement, the location of transit lane, and the operation of the intersection.

Transit vehicles facing a normal red indication and an illuminated white transit vehicle indication may proceed with caution through the intersection.

Upon termination of the transit phase, a normal red clearance interval is required before the signals revert to normal phasing. The transit priority signal may also be operated concurrently with other non-conflicting vehicular and pedestrian movements, as directed by the traffic control signal indications. When the vertical white bar is not displayed, transit vehicles must obey the normal traffic signals. The transit signals may be required only at certain times of the day, on certain days or for special events. The additional transit phase(s) can generally be programmed into the appropriate signal plan.

Reference documents on operating transit signal priority include the planning and implementation handbook by the U.S. Department of Transportation²⁶. The Transportation Association of Canada has just published a guide⁹ dedicated to transit signal priority and associated phasing and signalization. The guide provides additional information, but some concepts, such as transit signals oriented at 45 degrees, are not supported by the HTA. More information on transit priority signal timing is also provided in Section 3.9 – Preemption and Priority.

Movable Span Bridge Traffic Control Signals

When a roadway crosses a drawbridge, swing bridge or lift bridge, normal traffic signal heads should be considered in conjunction with control gates or other forms of physical protection. The traffic signals and protection system are to be interconnected with the bridge mechanism in such a way that the signal indications will change to amber at least 15 seconds before the gates are closed, and will not show green at any time the bridge is not traversable. The all red interval should allow sufficient time for all traffic to clear the bridge deck before activation of the protection devices. In cases where areas of traffic congestion are present, traffic presence detection on the bridge may be required to detect any vehicles stranded on the bridge. Where railway crossings



Figure 16 – Lane Direction Signals

are present, another set of advance signals may be required to ensure that vehicles are not trapped and forced to stop between the bridge barrier and the railway tracks. Where signalized intersections are within 150 m of the bridge signals, they are to be interconnected with the bridge signals and upon activation of the bridge signals, they are to enter preemption mode, resting in red in the direction approaching the bridge. Where the bridge has pedestrian walkways, it may be necessary to supply pedestrian signals and calculate the all red time to be sufficient to allow pedestrians to clear the bridge before the span moves.

A great deal of care should be taken with the design of bridge signals as it is not possible to stop large water vessels in a short distance and, once activated, the bridge mechanism has to continue to open the bridge. It is good practice to allow a distance of at least 15 m between the end of the movable part of the bridge and any barrier protection. This space provides storage for one or two vehicles in an emergency.

Lane Direction Signals

Lane direction signals (see Figure 16) are used to legally indicate the direction of traffic flow on reversible direction lanes. The downward green arrow indicates right-of-way in the lane for through traffic approaching the display. A red “X” indicates that approaching traffic must not travel in the lane. A separate display must be used over each reversible lane, and the heads are normally mounted back-to-back provided visibility from both directions permits.

Lane direction signals may be used in conjunction with control gates to physically indicate closure of lanes or roads.

Amber “X” indications are not used for clearance intervals in Ontario. A flashing red “X” can, however, be used as a clearance interval. Where hardware does not allow for a flashing red “X” clearance, it will be necessary to allow enough phase time to allow a vehicle travelling at posted speed plus a buffer time to completely clear the full length of the lane (by use of a long all-red clearance interval) before switching to the reverse direction. Alternatives to this method involve vehicle detection and axle counting and controller software modifications that allow reversal on lane clearance. TAC has now published national guidelines on the use of reversible lanes systems. Entitled “Guidelines for the Planning, Design, Implementation and Evaluation of Reversible Lane Systems (2010);” the guide is described by TAC as “offer(ing) roadway design practices and suggested warrant guidelines / thresholds, as well as an evaluation of multiple configurations, addressing left turn issues and safety considerations. Systems capacity and evaluation / assessment methods are also included.”

Automated Flagger Assistance Devices

An automated flagger assistance device is intended to augment a traffic control person, and is used to separate two-way traffic operations through a single lane. One device is placed at each end of the lane closure. The device displays a red or amber lens, generally in conjunction with a control arm. An automated flagger assistance device is **not** considered a traffic control signal according to the HTA, allowing each road authority to establish its own policies to govern the use of automated flagger assistance within construction zones. More details on the setup and conditions of use of these devices are listed in Section 5 of this manual.

Portable Lane Control Signals

Portable Lane Control Signals consist of at least one “standard” vehicle traffic signal head, normally mounted on a movable pole. The signals are sometimes used to reduce traffic flow to a single lane in alternate directions at very local work areas requiring lane closures. Road authorities may establish their own policies governing the use and application of portable lane control signals. More information is provided in Section 5 of this manual.

Portable Temporary Traffic Signals

Portable Temporary Traffic Signals consist of standard traffic signal heads mounted on movable trailers. The trailers are typically positioned at intersections to emulate traffic control signals. They may also be used as portable lane control signals for short or very short duration work. No legal drawings are required if these devices are operated while attended on site. Road authorities may establish their own policies governing the use and application of portable temporary traffic control signals. More details are provided in Section 5 of this manual.

Temporary Traffic Signals

Temporary traffic signals typically consist of traffic signal heads positioned on span wires or temporary poles. Temporary signals are intended to be used as an alternative to permanent traffic signals for limited periods before or during the re-construction of roadways. More details are provided in Section 5 of this manual.

Accessible Pedestrian Indications

Signalized intersections used by the visually impaired may be equipped with auxiliary audible or tactile devices that provide additional information about the status of the intersection or the traffic

signals, and help the visually impaired to cross the road. The decision to use these devices at a specific traffic signal location may be best determined by a recognized agency or body trained in the needs of the visually impaired, such as the Canadian National Institute for the Blind. If an intersection is equipped with an accessible signal system, the system can advise the visually impaired pedestrian (and those pedestrians with both visual and hearing impairments) of some or all of the following: that the intersection is equipped with special signalization features for the visually impaired; where the pushbuttons may be found; the direction for which each of the pushbuttons activates the special features; and when, and in which direction, to start crossing the street. The new style of accessible signals supercedes the concept of audible signals which consisted only of a sound associated with the Walk interval for sighted pedestrians.

The accessible equipment may include a number of features beyond audible tones for the “Walk” intervals. The additional features may consist of tones that locate the pushbuttons, tones that acknowledge that the button has been pushed or vibrating features that operate in parallel with the audible sounds. These traffic signal features operate in conjunction with typical accessibility features in the sidewalk and crosswalk. The activation of these devices at traffic control signals should include a training program for users provided by an agency recognized as dealing with the needs of the visually impaired.

Accessible indications are not covered by the HTA. Basic standards and pushbutton operation options are provided in the MUTCDC¹⁴, but the existing audible signal standard in the MUTCDC has been reviewed, and the changes approved. The MUTCDC will be updated with a more comprehensive accessible signal standard in the very near future. Two significant changes (compared to the older audible standard) have been made: one of the Walk tones has been changed from a “chirping”

or beeping tone to the “Canadian Melody;” and it is now recognized that the sounds need only be heard as far as the edge of the curb and not across most of the crosswalk. While the MUTCDC has not yet been updated, the standard is available as a standalone document entitled “Guidelines for Understanding, Use and Implementation of Accessible Pedestrian Signals (2008)”¹⁵. For more information, refer to <http://www.tac-atc.ca/>.

Pedestrian Countdown Signals

Pedestrian countdown displays supplement the regular Walk and Flashing Don’t Walk symbols with a numeric countdown of the number of seconds left in the interval(s). Most countdown pedestrian heads available today determine the display time using the durations of pedestrian intervals from previous cycle(s). As a result, phases which are more consistent in duration are more appropriate for countdown pedestrian heads because of the associated accuracy in the countdown display time.

TAC has completed a project that provides comprehensive recommendations on the operation of countdown timers. The key recommendation is that the timers should operate only during the pedestrian clearance interval to ensure the timing consistency noted above.

Tunnel Signals

“Tunnel Signals” may consist of signals at the ends of a tunnel used to prohibit the entrance of traffic, lane control signals within the tunnel, and signals on the tunnel approaches. Signals are also used for reversible lanes or for the closure of lanes for maintenance.

Signals located near the ends of a tunnel should be constructed at crossing roads so that traffic may be diverted should it be necessary to close the tunnel. The tunnel may be closed by a manually

activated or automatic preemption signal sent to the controller. The preempt signal may come from the tunnel alarm systems for, for example, fire, collision, noxious gases or water leakage. The signals operate similarly to those for railway preemption.

The principles of the use of symbols, visibility distances and operational strategies as outlined under “Lane Direction Signals” also apply to tunnel signals.

Ramp Metering Signals

Ramp metering signals are used on freeway or expressway entrance ramps to control the rate of traffic flow onto the highway. Metering signals normally operate only during rush hours and in a preferred direction (normally toward the Central Business District (CBD) in morning and outbound from the CBD in the evening).

Ramp metering signals are normally controlled by traffic management computer software at the Traffic Operations Centre. The signals have a controlled cycle length that depends on the volume/density of the highway lanes. When the highway is operating at LOS E, the ramp metering cycle length will be relatively long (e.g., 15 seconds) so that the number of vehicles per hour is restricted in order to alleviate the highway congestion. When the highway speeds and volumes increase and volumes of throughput increase, the central computer commands a relaxation in the ramp metering cycle (e.g., 5 seconds), thus allowing more vehicles per hour from the ramp to enter the highway.

The ramp metering station (RMS) itself requires a controller with modified software/firmware to access values of minimum green and amber which are normally disallowed for intersection controllers. The green time is normally set to a very short interval, in the order of 1.0 seconds (one vehicle only per green signal), with the amber interval even shorter (in the order of 0.5 seconds). The signals rest in red for the remainder of the cycle, and must

be activated by a detector when the system is running. The ramp metering signals typically rest in green during the off-peak hours of the day.

Ramp metering signals are always used in conjunction with an advance flasher to indicate that RMS is in operation.

Optically Programmable Traffic Signals

Optically Programmable Signal indications can be used to limit the visibility of signal indications to specific areas. These types of indications are generally used to avoid conflicting or confusing indications to drivers approaching in adjacent lanes or approaching signals that are very closely spaced. Example applications include left turn indications on high speed roadways with centre medians, and unusual geometric intersection configurations. The optically programmed heads are also used where signalized intersections on the same roadway are so closely spaced that drivers may look past the closest signal to the one farther away, resulting in violations and collisions.

Many programmable signal indications are designed to veil the areas where the signal indication is to be restricted by applying opaquing material to portions of the signal lens (which actually consists of an optical window located within the signal head). The veiling process is generally done by opening the back door of the head, looking through the window at the approach, and “taping off” areas where the indication is to be restricted. This process is almost always done after the signal is placed and aligned at the intersection. Typically these signal heads are rigidly mounted so that the programming will remain consistent in relation to the area of the roadway for which the signal indication should be visible or veiled.

Road authorities should routinely confirm that the programmable indication is visible within the intended boundaries, and that the signal head has not shifted or moved. This routine check could be

made a standard part of the maintenance practices, and should apply for all traffic signal locations with optically programmable traffic signals.

Further specifications are available through the ITE at <http://www.ite.org/standards>.

Bicycle Signal Indications, Timing and Phasing

Bicycles are defined as vehicles in the Highway Traffic Act and are therefore governed by the rules of the road as defined in the act. Under the vast majority of circumstances, standard vehicle displays, standard signal phasing, and standard signal timing and clearance intervals should be adequate to control bicycle movements through intersections, but in very unusual conditions, where bicycles make up the majority of vehicle flow, it may be necessary to have a slightly longer minimum green time. The use of bicycle specific signals and/or bicycle phasing should be limited to special circumstances where safety or efficiency can be improved for cyclists or other users, and not randomly or universally applied to all signalized intersections.

Bicycle specific signal lenses are not currently approved under the HTA. These lenses are in use in other provinces and have been included in the 2008 update to the MUTCDC along with information on the mounting of bicycle signals. In Ontario, standard signals can be used for bicycle-specific purposes. In this case, it is recommended that, the requirements of the HTA are satisfied such that two heads are provided in the direction of travel. In addition, various techniques may be used to ensure that the intent of the bicycle signals is conveyed to all road users, and that the bicycle signals are distinct from other indications. Techniques include the size and colour of the signal heads, the lack of backboards, signing that clearly identifies the purpose of the signal heads, and proper positioning. As an additional precaution, where bicycle signals are

operated in a parallel direction with other signals, displaying the amber phases simultaneously, if possible, will minimize possible confusion.

Separate bicycle signal phases may be required in unique situations, typically when a heavily-used off-road bicycle trail or multi-use trail crosses through a signalized intersection in a way that cannot be combined efficiently or safely with existing vehicular or pedestrian phases. The Transportation Association of Canada is planning to make available the Traffic Signal Guidelines for Bicycles report which will provide information on bicycle traffic signals, phasing and timing. This guide will contain additional material about these topics. Please refer to the TAC Transport Information Service for added information. The contact email is TIS@tac-atc.ca.

3.11 Flashing Beacons

General

Flashing beacons may be used at locations where full traffic control signals are not justified, but lack of visibility or other hazards mean that regulatory or cautionary signs alone are not sufficient. Flashing red or flashing amber indications may be shown. The red indicates that all approaching traffic must stop before proceeding, and the amber indicates that traffic may proceed with caution provided that the way is clear. The red flashing beacon is always used in conjunction with stop control for the same direction.

Beacons must be clearly visible to approaching motorists for the distances shown in Section 5.

Beacons must be flashed at a rate of not more than 60 or less than 50 ON and OFF flashes per minute, with the length of each ON period approximately equal to the length of each OFF period.

Beacons should be used with considerable discretion because over-use of these devices may lead to their being disregarded by motorists. The decision to install flashing beacons should be based, at least in part, on a higher than expected collision risk, and the presence of a pattern of collisions of a type which should be prevented or reduced in number by the installation of the flashing beacon.

Hazard Identification Beacons

Hazard beacons include those used for reinforcement of signs or signing systems. Examples of the use of hazard beacons include their use for obstructions in or immediately adjacent to the roadway, and as a supplement to advance warning and regulatory signs such as KEEP RIGHT, STOP or SIGNALS AHEAD. Hazard beacons are also used as visual warning on pedestrian crossovers.

Beacons with flashing amber indications may be used to emphasize the need for caution. Studies that determine the justification for hazard beacons investigate problems identified at the intersection, the location's collision experience, and the presence of any of the following conditions:

- A physical obstruction in the roadway
- A sharp curve in the roadway
- A major intersection that is hidden by a sharp curve or severe grade
- The beginning of a divided highway (median)

Beacons in Advance of a Signalized Intersection

An amber "Keep Right" flasher on a median island shall be used only if it does not visually distract from nearby vehicular traffic signals. This type of flasher is therefore seldom used for traffic signal islands. These beacons are usually considered only in

locations that are a minimum of 300 m away from signals.

Intersection Control Beacons

General

Intersection control beacons consist of 200 mm or 300 mm diameter lenses with continuously flashing red or amber indications. Applications include: overhead beacons mounted on suspension wire at the centre of an intersection; and the provision of visual assistance where stop signs are not conspicuous, or sightlines to the major road are poor or in situations where the driver has not needed to stop for some distance and may not be expecting to have to do so.

Flashing beacons may be used when two major high speed roads intersect in a rural area, or when the collision history suggests that additional treatments are required.

It is generally intended that intersection control beacons operate on a continuous basis (aside from power failures, mechanical problems or other unforeseen events).

1-Way or 2-Way Overhead Red Flashing Beacons

1-way or 2-way overhead red flashing beacons are used where the visibility of intersections or stop signs is poor due to abrupt vertical curves or other visibility restrictions that result in poor stop sign compliance and/or collisions. The beacons provide additional visual assistance for normal stop signs.

These types of overhead beacons should use 300 mm red lenses, and should be positioned to be clearly visible along each approach of the side road. Stop signs must also be located at the intersection.

3-Way and 4-Way Overhead Red Flashing Beacons

3-way or 4-way overhead red flashing beacons are used where “all-way” stop conditions are in place, but traffic control signals are not justified. The beacons are used where geometric conditions, visibility conditions or the collision history suggest that the stop signs require reinforcing.

These types of overhead beacons should be positioned to be clearly visible along each approach. Stop signs must also be used on each approach.

3-Way and 4-Way Overhead Red/Amber Flashing Beacons

3-way or 4-way overhead red/amber flashing beacons are used where the side road traffic is required to exercise caution and stop, but traffic control signals are not justified. The beacons are used where geometric conditions, visibility conditions or the collision history requires reinforcement of the normal stop signs, and where side road traffic may have difficulty turning due to limited sight distance.

These types of overhead beacons should be positioned to be clearly visible along each approach of the intersection with the red beacons facing the side road(s) and the amber beacons facing the main road. Stop signs must be located on the side road approaches.

Red Beacon for Stop Sign Reinforcement

A red beacon for stop sign reinforcement is typically used above an oversized stop sign. The beacons should be 200 mm diameter to prevent excessive glare caused by the low mounting height. The beacons must operate 24 hours a day.

Warning Beacons in Advance of Signalized Intersections

In general, warning beacons in advance of signalized intersections should be implemented if one or more of the following criteria are met:

- The view of the signals is obstructed due to vertical or horizontal alignment (due to buildings, rock cuts or large signs along the inside of curves) such that the traffic signal indications are not visible for the minimum sight distances, as described in Section 5.
- Freeway conditions come to an end at a signalized intersection.
- The grade approaching the intersection is sufficient to require more than normal braking effort.
- Where the beacons can provide a supplement to double long distance detection on downhill approaches (except for true active advance warning). As well, authorities may wish to consider use of warning beacons if motorists are exposed to many kilometres of travel without encountering a traffic control signal.

In addition, jurisdictions may consider the use of warning beacons in advance of a signalized intersection if drivers are exposed to a long distance of travel without encountering a traffic control signal.

Warning beacons can be in the form of full-time flashing operation, or one of two types of operation interconnected with the traffic controller, as described in the next sections.

Continuous Advance Warning Beacons for Traffic Signals

Continuous advance warning beacons for traffic signals are single 200 mm diameter beacons. They are used as reinforcement for the “Traffic

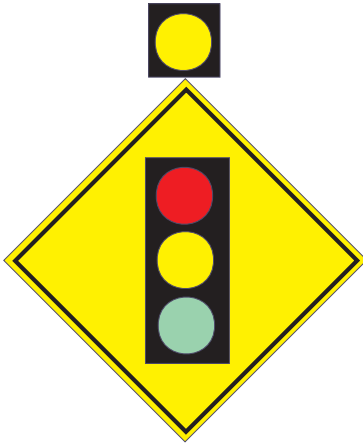

Figure 17 – Signalized Intersection Warning Beacon

“Signals Ahead” warning signs where the visibility of intersections with traffic control signals is restricted, where signal observance is found to be substandard, or where signals may not be expected by motorists such as on remote highways. A typical configuration is shown in Figure 17.

Continuous advance warning beacons may be used in advance of signalized intersections where there may be limited sight distances (due to buildings, rock cuts or large signs along the inside of curves) or on abrupt vertical curves in locations where the traffic signal indications are not visible for the minimum sight distances, as described in Section 5. In these situations, continuously operating single flashing beacons with the oversized “Signals Ahead” sign (Wb-102A) may be required. The location of the signs shall be in conformance with the requirements shown in Book 6 - Warning Signs.

Active Advance Warning Beacons for Traffic Signals

Active advance warning beacons consist of a special oversized Traffic Signals Ahead warning sign (Wb-202A), two alternating flashing amber beacons (200 mm) (one mounted on each side of the sign) and a



Figure 18 – Active Advance Warning Beacon

word tab (Wb-102At), that reads “Prepare to Stop When Flashing” mounted below the sign. Figure 18 shows a typical arrangement. The word tab must be bilingual in designated areas. The signs should be illuminated with a down light at night to prevent message washout from the flashing beacons. The beacons are interconnected to the traffic control signal and are activated at the beginning of the corresponding amber signal display. The beacons continue to flash until the approach receives the next green signal indication. The beacons should also flash when the traffic control signal goes into flash operation.

Successful operation of active advance warning beacons is directly related to accurate placement of the sign. If located too close to the intersection, the sign may not provide sufficient advanced warning. If the sign is located too far from the intersection, a motorist passing the sign may have insufficient time to clear the intersection.

In order to ensure efficient and safe intersection operation, the following equation should be used:

$$D_A = Vt_y - D_p$$

Where:

- D_A = distance of the active advance warning sign from the stop bar (m)
- V = operating speed (85th percentile speed or 10 km/h above the posted speed limit (m/sec)
- t_y = amber time (seconds)
- D_p = minimum distance at which the flashers can be perceived (21.3 m)

True Active Advance Warning Beacons for Traffic Signals

True active advance warning signs are interconnected with the traffic signal controller. They are similar to active advance warning beacons, but instead of commencing flashing at the start of amber, they are programmed to start flashing a pre-determined time before the amber. They continue to flash until the approach receives the next green indication. The operation of this device is intended to provide motorists with additional information, compared to other types of advance beacons, about the operation of the traffic signals, in order to assist the driver in making decisions. These devices consist of a Signals Ahead warning sign (Wb-102A), two alternating flashing amber beacons (20 cm) (one mounted on each side of the sign), and a tab sign (Wb-102At) that reads "PREPARE TO STOP WHEN FLASHING". This tab must be bilingual in designated areas. These signs should be illuminated with a down-light at night to prevent message washout from the flashing beacons. The beacons should also flash if the signal goes into flashing operation. The sign must be accurately located in order to be effective.

True Active Advance Warning Beacons provide the motorist with valuable information related to the existing or impending state of the traffic control signal at an approaching intersection. Motorists viewing the sign as it is activated are provided with a true warning that they are about to lose the right-of-way at the intersection and should adjust their speed accordingly. Motorists who are just past the

sign as it is activated are provided with sufficient time to travel through the pre-defined dilemma zone before the amber is displayed.

True Active Advance Warning Beacons **should only** be implemented when the intersection operates in fixed time mode or is semi-actuated (with no advance detection on the approach where the sign is being considered).

Since the safety advantages of signal "gap-out" are diminished by adding a pre-amber flash time, True Active Advance Warning Beacons are not recommended for use in combination with Long Distance Detection. True Active Advance Warning Signs should never be used in combination with Double Long Distance Detection.

The key elements related to the successful operation of True Active Advance Warning Beacons are related to the accurate placement of the sign and to the calculation of the advance flash time provided before the onset of amber. The sign should be placed before the stop line, at a distance equal to that required to bring the vehicle to a comfortable stop. Recommended sign placement is shown in Figure 19 and is summarized in Table 10. The distance is calculated using the following equation:

$$D_{TA} = VT_{pr} + \frac{V^2}{2a}$$

Where:

- D_{TA} = distance of the True Active Advance Warning Sign from the stop bar (dry stopping distance (m))
- V = operating speed (85th percentile speed or 10 km/h above the posted speed limit (m/sec))
- T_{pr} = perception reaction time (1.8 seconds recommended)
- a = average deceleration rate (3.06 m/sec/sec or 11 km/hr/sec recommended)

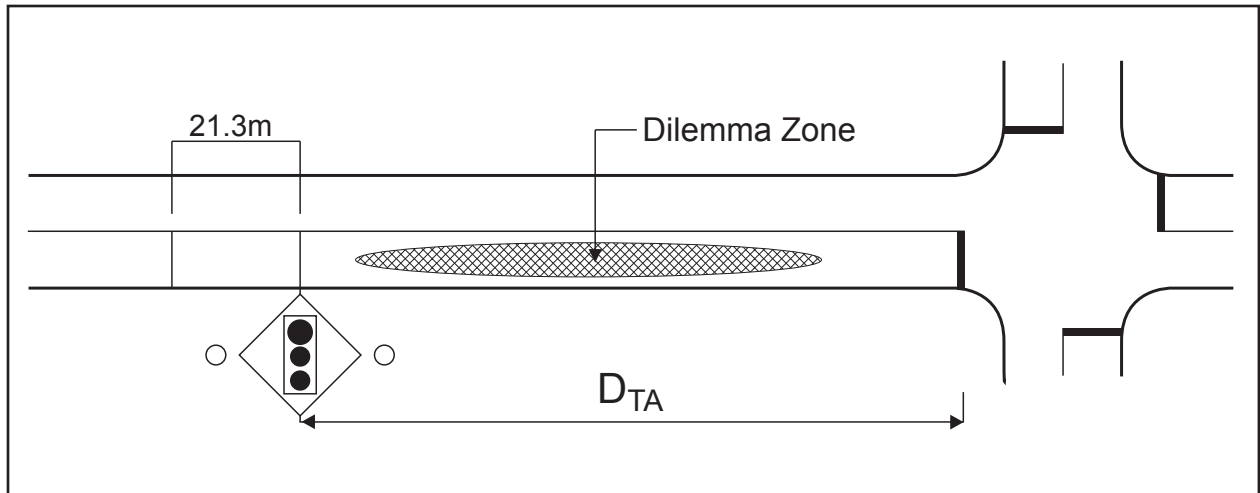

Figure 19 – True Active Advance Warning Beacon - Recommended Installation

* Figure 19 shows the recommended installation of a True Active Advance Warning Sign.

The advance warning flasher should be timed to begin a pre-determined number of seconds before the signals change to amber. This time is calculated so that a driver who passes the advance flashers just a fraction of a second before they are activated is afforded time to clear the dilemma zone safely. The length of time the signs flash before the signals change to amber is summarized in Table 10, as calculated using the following equation:

Table 10 – True Active Advance Warning Beacon Placement

OPERATING SPEED (km/h)	PRE-AMBER FLASH TIME (TBA) (seconds)	SIGN PLACEMENT (D _{TA})* (metres)
60	4.8	75
70	5.1	97
80	5.4	121
90	5.7	147
100	6.1	176
110	6.5	208
120	6.9	242

* Distance is measured from the stop bar.

$$TBA = \frac{D_{TA} + D_P}{V} - t_D$$

Where:

TBA = time before amber (pre-amber flash time, seconds)

D_{TA} = distance of the True Active Advance Warning Sign from the stop bar

D_p = minimum distance at which the flashers can be perceived (21.3 m)

V = operating speed (m/s)

t_D = 1 second

3.12 Systems

Need for a System

Traffic signal control systems can be used to operate, monitor and control traffic signal controllers located at each intersection. Traffic signal control systems can be very cost effective if frequent adjustments to the timing are required, or if more dynamic forms of control are indicated, or if frequent retrieval of the traffic data is necessary.

Traffic signal control systems can also be integrated with other systems such as freeway traffic management systems, transit control centres, or fleet management systems. More information on system integration can be found in the ITS Architecture for Canada (see <http://www.wapps.tc.gc.ca/innovation/its/eng/architecture/menu.htm>).

A feasibility study should be undertaken to assess the need and justification for a traffic signal control system and, if justified, the most appropriate type of system for the present and projected requirements of the road authority.

3.13 Maintenance Considerations

Traffic control signals require regular maintenance to ensure that they are functioning properly, to maximize safety to the public, and to proactively avoid potential operational problems. The legislated component of required maintenance for traffic control signals is set out in the Municipal Act, Regulation 239/02 as amended. This Regulation is entitled “Minimum Maintenance Standards for Municipal Highways.” More information is available at www.e-laws.gov.on.ca.

Suggested traffic signal maintenance standards for consideration (including those listed in the Municipal Act) include the following:

Every 6 months

Traffic Control Subsystem

- Check conflict monitor

Every 12 months

Traffic Control Subsystem

- Vacuum cabinet
- Change filter
- Check cover plates
- Check heater/fan
- Check for pests
- Check/service cabinet joints and sealants
- Verify maintenance logs are being used
- Check that supporting documents/drawings are in cabinet
- Verify operation of system connection and communications

Display Subsystem

- Re-lamp signals (incandescent)
- Clean lenses
- Verify head alignments
- Check/service condition of hangers, backboards
- Check/service cabling for temporary signals
- Verify integrity of mast arms, brackets, poles, base bolts, back guys
- Verify integrity of pedestrian heads, pole and bases

External Detection Subsystem

- Clean/service pedestrian push buttons

- Check and verify operation of vehicle detectors
- Check and verify operation of emergency vehicle and railway preemption

Road authorities are encouraged to establish maintenance practices and schedules that reflect the needs of their own local circumstances provided they are compliant with the requirements listed in the Municipal Act.

Maintenance staff should stock standard equipment used for replacement purposes. The choice of hardware should consider ease of replacement and minimization of stock requirements. The Ministry uses Ontario Provincial Standards Drawings (OPSD) for traffic signal standardization purposes.

3.14 Other Considerations

Electrical Considerations

Traffic control signal design has traditionally been managed or approved by traffic engineers because the signals are a tool of traffic management and regulation. Traffic signal installations in Ontario are subject to inspections from the Electrical Safety Authority (ESA). Information on agency responsibilities and inspection details can be found in the latest amended ESA Bulletin (2-12) available through the ESA website (<http://www.esasafe.com>).

Other recommended practices with regard to the electrical design of traffic control signals include:

- Where in-house design capability does not exist, a consulting engineering firm with electrical design expertise in traffic signals may be selected.
- Municipalities may adopt methods and practices that best address the specific design requirements for their local signals.
- All electrical equipment items should be ESA approved as a safety measure and as part of a pro-active risk management process.
- Where contracts for the traffic signal installation work are let, the contractors should use qualified licensed electricians for the wiring, and qualified IMSA technicians for the controller setup. The contractor should obtain inspection and certification of a qualified staff electrical technician, qualified electrician, or qualified electrical engineer.

Aesthetic and Practical General Design Considerations

Although aesthetics play a minor part in the functionality of a traffic signal system, it should be kept in mind that local citizens see the equipment on an everyday basis. Since standard equipment is used in most installations, consideration of aesthetic values consists mainly of avoiding of signal elements that are not considered pleasing. The same choices that will satisfy aesthetic considerations will often lead to more efficient design and lower capital cost or maintenance requirements, and may serve to comply with disability requirements.

Examples of aesthetic considerations include:

- The number of poles should be kept to a minimum.
- The signal head displays and traffic signals are the only items we really want to notice. Poles and all other equipment should be as inconspicuous as practical.
- The length of single member arms should be kept to the minimum required to satisfy the criteria.
- The locations of corner poles with pushbuttons may lead to complaints if the poles are not installed in a way that is

compatible with sidewalks, if they are behind barriers, if the pushbuttons are on the wrong side, or the poles are sited where a pedestrian has to take a few steps in mud to reach the pushbutton.

- Where buildings are adjacent to the sidewalk, the poles should be sited so that no interference occurs with doors, windows or commercial signs. Spaces between poles and buildings should be a minimum of 1.5 m to allow space for sidewalk snowplows. In some locations, the space between poles and buildings should be closed to allow no more than a 450 mm space. (This may reduce the sidewalk width in tight spaces and will require agreement by the owners of the buildings.)
- Signal arms should project beyond overhanging tree branches so that future tree trimming can be controlled without excessive trimming of large branches.
- Controller cabinets should be oriented to be parallel to the roadway, particularly in urban areas. Where practical, the controller pad can be directly adjacent to and flush with the sidewalk, provided that offset rules are observed. In congested urban areas, care should be taken to place the controller free of store doors, windows, etc. and as clear of sidewalks as practical so as to provide a minimum 1.5 m sidewalk space.
- Excessive equipment on poles (particularly on utility poles with external conduits, straps, etc.) can be unsightly.
- Long signal arms on utility poles tend to tilt these poles towards the roadway. Guy anchors with sidewalk struts behind the mast arm attachment brackets can neaten these installations. The need for guy anchors should be discussed with the power supply authority as needed to decide who should do the work.

4. Planning and Justification

4.1 General

Purpose

This section discusses the planning and justification for a traffic signal installation. Traffic signals are not the only alternative available to provide right-of-way control. There is a range of other choices including stop signs, yield signs, and roundabouts. Traffic signals should only be selected if consideration of alternative options suggests that traffic signals are the best choice. A comprehensive study of the traffic conditions and the physical characteristics of the site should be undertaken to determine whether the installation of a traffic control signal would benefit the intersection operation.

Users should be aware of the advantages and disadvantages of traffic signals. Traffic signals can move traffic efficiently by distributing time and alternating the right-of-way judiciously. Traffic signals can also help to reduce the number of certain types of collisions. A poorly timed signal, however, is likely to serve traffic inefficiently. Users should also be aware that the installation of a traffic signal does not guarantee the elimination of all collisions, and the number of some types of collisions may increase following the installation of traffic signals.

Background/Context

The decision to install a traffic signal should be based on sound engineering judgment. This section provides guidance on a number of justification procedures that should be used to assist in determining the need for traffic signals. The fulfillment of a traffic signal justification or justifications does not in itself require the

installation of a traffic signal. Justifications must be used in combination with traffic engineering experience, professional judgment, and economic analysis. Satisfying signal installation justifications is only one criterion for determining the suitability of traffic signals for any location.

Even if the evaluation of a location meets a justification, a traffic signal should not be installed if the signal will result in operational problems that create a potential for collisions and/or significantly increase delays to all users. Section 4.13 provides guidance for a procedure that can be used to assess the potential impact of signalization on collisions. Other potential problems should also be assessed. The problems include the extension of vehicle queues through upstream intersections, and possible impacts on existing signal progression. These broader network considerations must be taken into account, and necessitate the application of engineering judgement over and above strict reliance on justification criteria.

This section identifies seven distinct justifications for traffic signal installation. Other considerations that support justification for a signal installation may also arise. For example, if visibility at a location is inadequate for the safe and efficient operation of the intersection in its unsignalized state, and if geometric or operational improvements cannot resolve the situation, experience and professional judgement may support signal installation. An experienced analyst may also consider benefits to other users such as public transit, cyclists or pedestrians that may flow from signalization.

4.2 Information Requirements

Basic Input Data

Various basic data and location attributes are required for the analysis of signal justification. Table 11 lists and describes the basic data required for the volume, collision and pedestrian components

of Justifications 1 through 6. Comments providing additional guidance about the collection and application of the data are also included in the Table.

Table 11 – Traffic Control Signal Justification: Data Input Requirements

Justification 1 - Minimum 8 Hour Vehicle Volume Justification 2 - Delay to Cross Traffic Justification 3 - Combination Warrant Justification 4 - Minimum 4 Hour Volume		
Information Required	Description	Notes/Comments
Intersection Configuration	Number of approaches. Number of lanes on each approach.	Three or four leg intersection. Divided into left, through, right, and channelized right turn lanes.
Traffic Volumes	Number of vehicles entering the intersection during the eight highest hours of an average day categorized by those passing left, through and right.	Vehicles should be categorized into passenger cars, trucks/buses, and bicycles.
Pedestrian Volumes	Number of pedestrians crossing each leg of the intersection during each of the eight highest hours of an average day.	Eight hour pedestrian volume should coincide with the eight highest traffic volume hours.
Roadway Speed	Design, operating, or posted speed on the main roadway during the signal justification analysis period.	For future roadways, the design speed on the main roadway should be used. For existing facilities, the operating or posted speed should be applied. If either figure exceeds 70 km/h, the intersection is assumed to function under free flow conditions.
Area Population	Approximate population of built-up or urban area.	Quantitative measure that assists in determining whether the intersection is operating under free flow (rural) or restricted flow (urban) conditions.

Justification 5 - Collision Warrant		
Information Required	Description	Notes/Comments
Intersection Configuration	Number of approaches.	Three or four leg intersection.
Traffic Volumes	Traffic volume. Entering AADT volumes for major and minor streets. Expected volume after signalization.	At least three years of historical AADT volumes should be provided. The years should correspond to collision data years. If known, expected traffic volume following the installation of the signal.
Collision Data	Most recent three or more year history of reported collisions. Initial impact type detail.	Collision history should be as current as possible. A shorter time period may be used if major changes to the intersection have taken place. Collision data must be sufficiently detailed to allow the determination of initial impact type, so that the collision can be categorized as susceptible to reduction ("Reducible") or not-susceptible to reduction ("Non-reducible") following signalization. Reducible collisions include: Angle and Turning Movement. Non-Reducible collisions include: Rear End, Approaching, Sideswipe, Single Motor Vehicle and Other.

Justification 6 - Pedestrian Volume and Delay Warrant		
Information Required	Description	Notes/Comments
Roadway Configuration	Number of lanes on the main road. Presence of median island.	Divided into left, through, right and channelized right turn lanes. Width of median, if any, on main street.
Traffic Volumes	Total number of vehicles in both directions during the eight highest hours of an average day.	Vehicles should be categorized into passenger cars, trucks/buses and bicycles.
Pedestrian Volumes	Number of pedestrians crossing main roadway during the same eight highest hours of an average day.	Total pedestrian volume categorized as "assisted" (children under the age of 12, seniors, and mobility challenged) or "unassisted," and segregated by zones.
Pedestrian Delay	Delay time experienced by each pedestrian for the same eight highest hours of an average day.	Eight hour monitoring of delay is desirable but delay counts for brief periods can be factored up to create eight hour totals. A minimum of two one-hour peak periods should be surveyed.
Pedestrian Crossing Opportunities	Percentage of pedestrians from each zone.	A qualitative assessment of the percentage of each zone's pedestrians who would choose to use the proposed crossing control.

Flow Conditions

The justification for traffic signals has been developed for two types of flow conditions: restricted flow and free flow. The two types are necessary to reflect different operating characteristics. Engineering judgment should be used in determining which condition best describes the study location under existing operating conditions or for a predetermined future analysis scenario:

- Restricted Flow Conditions represent roads with operating or posted speeds of less than 70 km/h and are normally encountered in urban areas where side friction on the roadway (due to parking, numerous entrances, etc.) reduces the operating speed.
- Free Flow Conditions represent roads with operating or posted speeds equal to or greater than 70 km/h and are normally encountered in rural areas or on controlled access roads in urban areas. As driving characteristics in small urban communities can be different from those in larger urban areas, free flow conditions are also used for isolated communities with a population of less than 10,000 and located outside the community influence of a large urban center, even if the operating speed is less than 70 km/h.

Intersection / Roadway Configuration

Roadway Type

The minimum justification values in Justifications 1 and 2 (minimum 8 hour vehicle volume and delay to cross traffic) for main road volume are given for a two-lane, two-way roadway and for a multi-lane roadway with four or more through lanes. Vehicle volume justification values for multi-lane roadways having four or more through lanes on the main road are 25% higher than the values for two-lane, two-way roadways. Two-lane, two-way roadways with exclusive left-turn lanes are generally not classified

as multi-lane roadways, but engineering judgement should be used to determine whether the inclusion of left and right auxiliary turn lanes in the main street approach configuration is appropriate. If vehicles encounter conflicts or delays in turning from a right turn lane, it could be included. The main street approach should be considered a multi-lane approach if approximately half of the traffic on the approach turns left and the auxiliary lane is of sufficient length to accommodate all left-turn vehicles.

Median Islands

For the application of Justifications 1 through 4 (traffic volume-based warrants), an intersection with a wide median, even a wide median greater than 9 m, should be considered as one intersection. For the application of Justification 6, each direction on a divided roadway with a raised median island of at least 1.2 m may be considered individually in the justification process.

Traffic Volume Data

Main Road

The main road should be the road that carries the greater hourly vehicular traffic volume over the period of study. As this "main road" may not, however, carry the greater volume during each of the hours studied, it is possible to refine the definition of main road to incorporate analysis on an hour-by-hour basis. Where the intersecting volumes are approximately equal, the road having the less restrictive form of existing control is generally selected as the main road.

Determination of an Average Day

The traffic and pedestrian volumes used in the analysis should be representative of traffic and pedestrian volumes likely to be experienced on an average day, i.e., the typical operating conditions that the signal is intended to address. When signal justifications are met on days other than weekdays, signals may be justified on the basis of recurring congestion, but their design and operation should

reflect the variations in their use. Example of these conditions may include roadways in:

- Retail oriented areas that are congested on Saturdays and Sundays rather than during weekdays
- Recreational areas that experience peak traffic conditions only during summer weekends
- Employment areas where major shift changes or other operational attributes result in peak travel during periods outside typical morning and afternoon weekday peak periods
- Special event areas such as stadiums, arenas, exhibition grounds, theme parks and community centres where there is recurring congestion on a relatively frequent basis

In each of the above cases, the signal should be operated to avoid causing undue delay during periods when demand is lower.

The hours counted should reflect the eight highest hours of the day. Traffic volumes normally vary hourly, daily, monthly, seasonally, and annually. If the counts available are for the periods other than the one(s) of interest, the counts may be factored appropriately with reference to local or provincial experience. Guidance relating to temporal variations and appropriate adjustment factors is provided in the Traffic Characteristics section of the Geometric Design Standards for Ontario Highways (MTO 1999)⁵. Alternative references include Section 4 of the Institute of Transportation Engineers Traffic Engineering Handbook²⁵, and Chapter 8 of the Highway Capacity Manual 2000¹¹.

Vehicle Counts

Only vehicles entering the intersection should be considered. The vehicles may turn right, go straight through, or turn left. If the right turns are free-flowing, channelized and effectively segregated from the through traffic by means of a physical island, vehicles turning right are not considered to

enter the intersection, and should therefore not be included in any justification calculations.

Bicycles

For the purposes of traffic signal justification analysis, bicycles must be treated as vehicles when on the road. Bicycles should be treated as pedestrians at the intersection of roads and park paths where cyclists dismount to cross the road.

Heavy Vehicle Movements

At locations in or near heavy industrial, manufacturing, agricultural, or natural resource extraction areas, heavy vehicle travel may impact on signalized intersection flow or capacity. In these cases, engineering judgement and visual observations of delay, roadway grades, and conflict potential will be required to determine whether a heavy vehicle adjustment factor should be applied to reflect the site specific operational characteristics. Heavy vehicle adjustment factors ranging from 1.5 to 3.5 passenger car unit equivalents (PCUs) have been applied in many operational analysis methodologies. ITE's "Canadian Capacity Guide for Signalized Intersections"¹ (CCG) provides some guidance to the application of passenger car unit equivalents.

Pedestrian Volume Data

For the purpose of Justification 6: Pedestrian Volume and Delay, an adjusted pedestrian volume is applied to reflect a factored volume based on "equivalent adults" and the following definitions:

- Unassisted – Adults and adolescents at or above the age of 12 are considered "unassisted" pedestrians.
- Assisted – Children under the age of 12, senior citizens, disabled pedestrians, and other pedestrians requiring special consideration are termed "assisted" pedestrians. In cases where an adult is accompanying a pedestrian included in the

“assisted” category, both individuals should be counted as “assisted” pedestrians to reflect their higher vulnerability. It should be recognized that the exact age of the pedestrian is not critical, but the observer will need to use judgement to place each pedestrian into one of the two categories.

The factored pedestrian volume is calculated as follows:

$$\text{Adjusted volume} = \text{Unassisted Pedestrian Volume} + 2 \times \text{Assisted Pedestrian Volume}$$

Collision Data

Reportable collisions are collisions involving personal injury or property damage that are serious enough to be reported by the police.

Supplementary Input Data

The following supplementary data may provide a more precise understanding of the operation of the intersection, and may assist the analyst to apply additional engineering judgement to the results of the signal justification analysis. Supplementary data that may be obtained for time periods for which the relevant Justification applies include:

- Vehicle Delay – Vehicle-seconds delay determined separately for each approach.
- Gaps – The number, length, and distribution of gaps in vehicular traffic on the main road when side road traffic experiences significant delays.
- Site Conditions – A condition diagram showing the intersection geometrics, lane arrangements, channelization, pavement markings, pedestrian paths, sight distance restrictions, and distance to nearest traffic signals. The condition diagram may also include approach grades, bus stops and

routing, on-street parking conditions, driveways, street lighting, utility poles and fixtures, and adjacent land use/plans.

4.3 Principles of Justification

General

The initiative for considering the installation of a traffic signal at an existing intersection or mid-block location often arises from complaints or from analysis regarding delay, congestion, safety, or pedestrian crossing problems. The resulting needs investigation begins with the collection of traffic, pedestrian, collision, and geometric data (as described in Section 4.2). An assessment of whether or not a signal is technically justified is made using the following criteria:

Justification 1 – Minimum Eight-Hour Vehicle Volume (Section 4.4)

Justification 2 – Delay to Cross Traffic (Section 4.5)

Justification 3 – Combination Warrant (Section 4.6)

Justification 4 – Minimum Four-Hour Vehicle Volume (Section 4.7)

Justification 5 – Collision Experience (Section 4.8)

Justification 6 – Pedestrian Volume (Section 4.9)

Justification 7 – Projected Volumes (Section 4.10)

For a traffic signal installation to be technically justified, at least one of the above justifications must be fulfilled. Unless one or more of the signal justifications are met, the installation of signals would not normally proceed as it would likely result in an increase in overall intersection delay and/or a negative impact on intersection safety.

4.4 Justification 1 – Minimum Vehicle Volume

Purpose

The Minimum Vehicle Volume Justification is intended for applications where the principal reason for installing a traffic signal is the cumulative delay produced by a large volume of intersecting traffic at an unsignalized intersection.

Justification 1A reflects the lowest total traffic on all approaches, and Justification 1B reflects the lowest volume on the minor road for which the average delay is similar for both signalized and unsignalized conditions. Therefore, this justification is intended to address the minimum volume conditions for which signalization can be used to minimize total average vehicle delay at the intersection.

As volumes increase beyond threshold criteria, delay to traffic on the minor road will increase, and the overall delay for the intersection will be greater than would be the case if minor delays were distributed between both main and minor roadways.

Standard

The need for a traffic signal must be considered if both Justification 1A and Justification 1B are 100% fulfilled.

If Justifications 1A and 1B do not reach or exceed 100%, but are at least 80% fulfilled, the lesser fulfilled of the Justifications 1A or 1B can be used in the assessment of Justification 3, the Combination Justification.

In applying Justification 1 (Minimum Vehicle Volume) for “T” intersections, the justification values for the minor street are increased by 50%. This approach reflects the reduction in traffic volumes due to the lack of one of the approaches.

Table 12 may be used for Justification 1: Minimum Vehicle Volume. Restricted Flow is applicable to Urban Conditions, while Free Flow is applicable to Rural conditions (see Section 4.2 for definitions).

Guidelines

Justification 1 evaluates total intersection volume and total minor road volume. The hours selected should represent the eight highest hours of the 24-hour traffic volume, and they do not have to be consecutive hours. Each one of the highest eight hours of the entering volumes is compared to the justification value. The justification should be met for each of the eight hours. “Sectional Percent” is calculated in Table 12 for reference purposes, and may indicate how close an intersection is to achieving full justification. “Total Across” is calculated by adding all 8-hour compliance percentages. The Compliance % figures used in Table 12 must not exceed 100%.

Table 12 – Justification 1 – Minimum Vehicle Volume

100% SATISFIED – YES NO
 80% SATISFIED – YES NO

APPROACH LANES	MINIMUM REQUIREMENTS (80% SHOWN IN BRACKETS)				PERCENTAGE WARRANT								TOTAL ACROSS
	1		2 or MORE		HOUR ENDING								
FLOW CONDITION	FREE FLOW	RESTR. FLOW	FREE FLOW	RESTR. FLOW									
A. ALL APPROACH LANES	480 (385)	720 (575)	600 (480)	900 (720)									
	100% FULFILLED												
	80% FULFILLED												
	ACTUAL % IF BELOW 80% VALUE												
TOTAL DOWN / 8 =													
B. MINOR STREET BOTH APPROACHES	120* (95)*	170* (135)*	120* (95)*	170* (135)*									
	100% FULFILLED												
	80% FULFILLED												
	ACTUAL % IF BELOW 80% VALUE												
TOTAL DOWN / 8 =													

* For "T" intersections, these values should be increased by 50%.

4.5 Justification 2 – Delay to Cross Traffic

Purpose

The Delay to Cross Traffic Justification is intended for applications where the traffic volume on the main road is so heavy that traffic on the minor road suffers excessive delay or hazard in entering or crossing the main road.

Standard

The need for a traffic signal must be considered if both Justification 2A and Justification 2B are 100% fulfilled. If Justifications 2A or 2B do not meet or exceed 100%, but both are at least 80% fulfilled, the lesser fulfilled of the justifications 2A or 2B can be used in the assessment of Justification 3, the Combination Justification.

Table 13 may be used for Justification 2: Delay to Cross Traffic. Restricted Flow is applicable to Urban Conditions, while Free Flow is applicable to Rural Conditions (see Section 4.2 for definitions).

Table 13 – Justification 2 – Delay to Cross Traffic

100% SATISFIED – YES NO
 80% SATISFIED – YES NO

APPROACH LANES	MINIMUM REQUIREMENTS (80% SHOWN IN BRACKETS)				PERCENTAGE WARRANT								TOTAL ACROSS
	1		2 or MORE		HOUR ENDING								
FLOW CONDITION	FREE FLOW <input type="checkbox"/>	RESTR. FLOW <input type="checkbox"/>	FREE FLOW <input type="checkbox"/>	RESTR. FLOW <input type="checkbox"/>									
A. MAJOR STREET BOTH APPROACHES	480 (385)	720 (575)	600 (480)	900 (720)									
	100% FULFILLED												
	80% FULFILLED												
	ACTUAL % IF BELOW 80% VALUE												
												TOTAL ACROSS	SECTIONAL PERCENT
												TOTAL DOWN / 8 =	
B. TRAFFIC CROSSING MAJOR STREET	50 (40)	75 (60)	50 (40)	75 (60)									
	100% FULFILLED												
	80% FULFILLED												
	ACTUAL % IF BELOW 80% VALUE												
												TOTAL ACROSS	SECTIONAL PERCENT
												TOTAL DOWN / 8 =	

Guidelines

Justification 2 evaluates major road volume and minor road movements that cross the intersection. The hours selected should represent the eight highest hours of the 24-hour traffic volume, and they do not have to be consecutive hours. The entering volumes of each of the highest eight hours are compared to the justification value. The justification is met if the justification value is 100% and fulfilled by each of the eight hours.

“Sectional Percent” is calculated in Table 13 for reference purposes, and may indicate how close an intersection is to achieving full justification. “Total Across” is calculated by adding all 8-hour compliance percentages. The Compliance % figures used in Table 13 must not exceed 100%.

As right turns are not considered as traffic crossing a road, they should be deleted from the combined pedestrian and vehicle volume in the Delay to Cross Traffic Justification. In one-way street systems, left turns from a one-way street into another one-way

street should be treated in a similar manner to right turns, and be deleted from the justification.

When applying Justification 2B, the crossing volume consists of the sum of:

1. The number of pedestrians crossing the main road
2. Total left turns from both the side road approaches
3. The highest through volume from one of the side road approaches
4. Fifty percent of the heavier left-turn traffic movement from the main road when both of the following criteria are met:
 - a) The left-turn volume is greater than 120 vehicles per hour
 - b) The total of the heavier left-turn volume plus its opposing volume is greater than 720 vehicles per hour

4.6 Justification 3 – Volume/Delay Combination

Purpose

Signals may occasionally be justified where neither Justification 1 or Justification 2 is 100% satisfied, but both justifications are at least 80% satisfied.

Standard

The requirements for the Volume/Delay Combination Justification are given in Table 14.

4.7 Justification 4 – Minimum Four-Hour Vehicle Volume

Purpose

The Minimum Four Hour Vehicle Volume Justification is intended for applications where the intersection experiences excessive delays for four or more peak hours of the day, but does not have the prolonged demands throughout the day to meet an eight hour warrant. The Ministry of Transportation, Ontario does not use the Minimum Four-Hour Vehicle Justification, but some jurisdictions may consider the Justification applicable for limited

Table 14 – Justification 3 – Volume/Delay Combination

Justification Satisfied 80% or More				Two Justifications Satisfied 80% or More	
Justification 1	Minimum Vehicular Volume	YES <input type="checkbox"/>	NO <input type="checkbox"/>	YES <input type="checkbox"/>	NO <input type="checkbox"/>
Justification 2	Delay to Cross Traffic	YES <input type="checkbox"/>	NO <input type="checkbox"/>		

Guidelines

Justification 3 should only be applied after an adequate trial of other remedial measures designed to reduce delay and inconvenience to traffic have failed to solve the operational issues at the intersection. Explicit consideration should be given to the safety benefits and disadvantages of installing traffic signal control. Section 4.13 of this section sets out an alternate recommended practice for undertaking and assessing the relative safety effects.

specific situations. The application of the four-hour warrant is focused on locations such as:

- Commuter-dominated roadways – with heavy demands for two or more hours in each of the AM and PM peaks, but considerably reduced demand for the remainder of the day
- Commercial areas – with limited demand in the morning, but a substantial four to six hour peak in the afternoon and early evening
- Manufacturing, office or industrial areas/ accesses – where minor street traffic experiences considerable delays when entering the major street during the mid-day and PM peak periods, but the AM arrival peak creates only low side street demands

Standard

The need for a traffic signal must be considered if an engineering study indicates that for each of the four highest hours of an average day, the plotted point representing the vehicles per hour on both major street approaches and the corresponding vehicles per hour on the highest minor street approach falls above the applicable curve outlined in Figure 20 (Rural - Unrestricted Flow Conditions) or Figure 21 (Urban - Restricted Flow Conditions).

No adjustments are made for “T” intersections as the methodology is based on the highest minor street approach volume, and is applicable irrespective of the configuration.

Guidelines

Where the highest volume minor street approach accommodates a heavy right turn volume, engineering judgment is required to determine whether a portion of the right turn volume should be excluded from the approach volume. The decision will depend on on site specific operational conditions. The degree of conflict and delay the minor street right turn traffic experiences while entering the main street is the primary consideration. Additional considerations include: the presence of a dedicated right turn lane; the presence of a wide minor street approach that allows right turns independent from left/through movements; or a high percentage of right turns in the minor street volumes. In general, the right turn volume should not be included in the minor street volume if the movement enters the intersection with minimal delay or conflict.

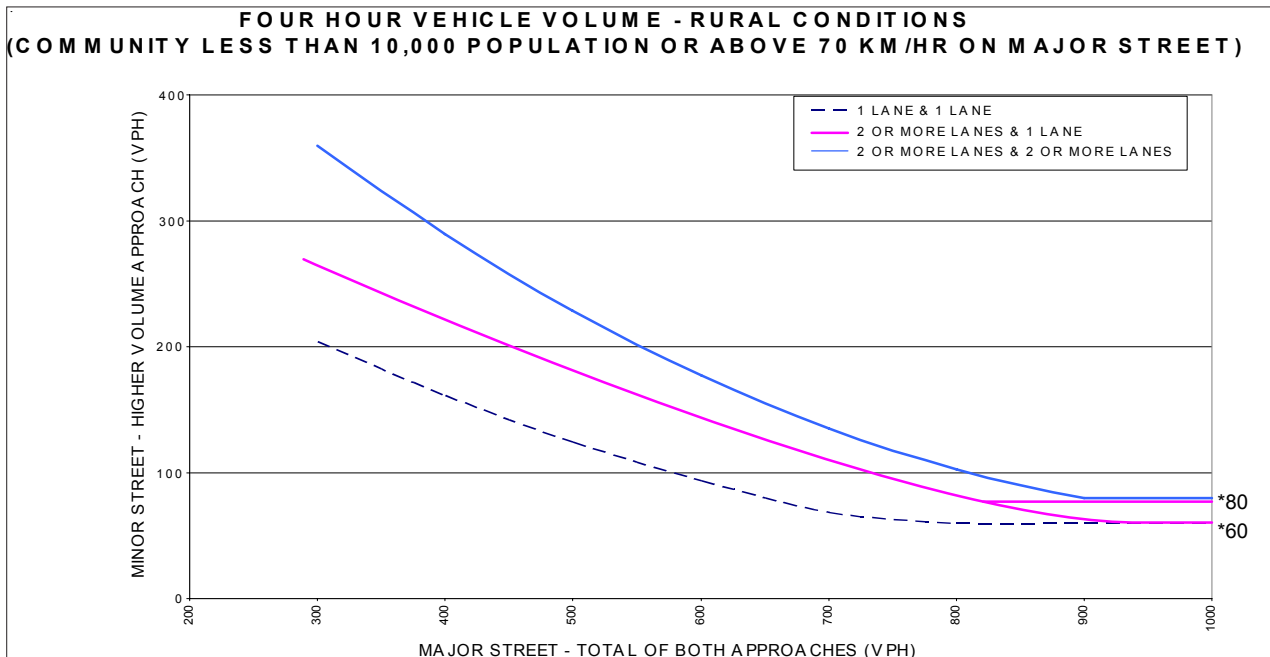

Figure 20 – Justification 4 – Minimum Four Hour Justification, Unrestricted Flow

*Note: 80 vph applies as the lower threshold volume for a minor street approach with two or more lanes, and 60 vph applies as the lower threshold volume for a minor street approach with one lane.

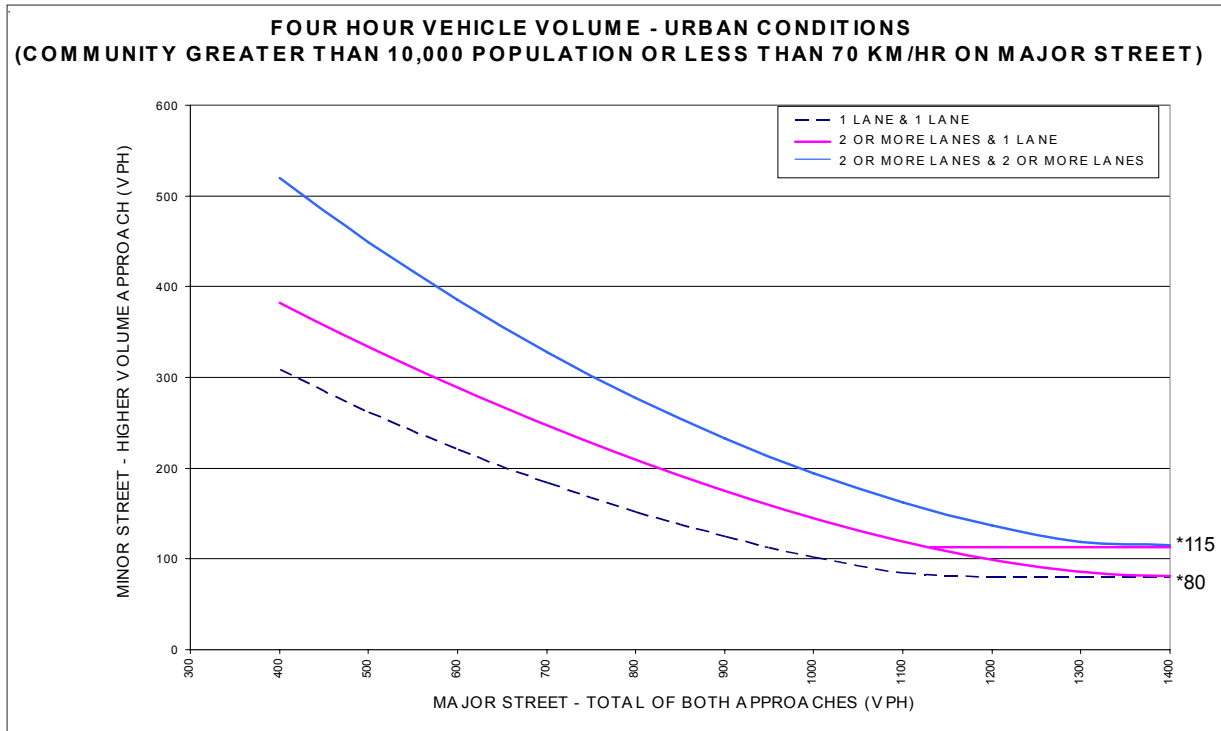

Figure 21 – Justification 4 – Minimum Four Hour Justification, Restricted Flow

*Note: 115 vph applies as the lower threshold volume for a minor street approach with two or more lanes, and 80 vph applies as the lower threshold volume for a minor street approach with one lane.

On the minor street, the “highest volume approach” need not be specified as the same approach during each of the four highest hours of the day.

Justification 4 is not to be applied in combination with the other traffic signal control justifications.

Requirements: The four highest hour volumes are plotted on the applicable figure, 20 or 21. If the plot shows that all four points lie above the applicable curve, the justification is satisfied.

4.8 Justification 5 – Collision Experience

Purpose

Traffic signals may be considered as one means of improving intersection safety where an unsignalized intersection has an unusually high collision history.

Standard

The approach taken in the following section is a practical and straightforward methodology. If the basic frequency method finds that a signal installation is justified, or nearly justified, the agency may wish to consider the alternative methodology

Table 15 – Justification 5 – Collision Experience

Reportable Collisions over 36 consecutive months susceptible to correction by a traffic signal			
WARRANT VALUE	TOTAL NUMBER OF CRASHES	OVERALL % COMPLIANCE	
15%	
Adequate trial of less restrictive remedies has failed to reduce accident frequency		Yes <input type="checkbox"/>	No <input type="checkbox"/>
Justification 5	100% Fulfilled	Yes <input type="checkbox"/>	No <input type="checkbox"/>
	80% Fulfilled	Yes <input type="checkbox"/>	No <input type="checkbox"/>

presented in section 4.13 to gain more insight into the decision. The alternative method requires more data and analysis, but many jurisdictions already have these data and analysis tools available. If the data and analysis tools are available, the advantage of the method given in section 4.13 is that it considers many additional factors such as: the background traffic volume; collision severity; the possibility that while preventable collisions may be reduced, other types may be increased; and the past experience a jurisdiction may have had when converting from the specific type of traffic control to signalization.

The installation of traffic signals may be justified when the conditions presented in Table 15 Justification 5 – Collision Experience are satisfied:

1. Fifteen or more reportable collisions of types susceptible to correction over a 36 month analysis period. Collisions susceptible to reduction are those involving vehicles and/or pedestrians which, under signalized conditions, would move on separate phases. Reducible collisions are described in detail in Table 11.
2. Adequate trial or consideration of less restrictive remedies with satisfactory observance and enforcement has failed to reduce collision frequency.

Guidelines

Less restrictive measures that could be tried before signals are installed include the improvement of control or warning signs, installation of flashing beacons, the provision of safety or channelizing islands, the improvement of street lighting, geometric or visibility improvements, shifting of bus stops, and/or the prohibition of parking and/or turns.

When applying Justification 5, consideration should be given to whether self-reported or police reported collisions are most prevalent. If self-reported collisions are prevalent, the accuracy of the collision history may be reduced.

The justification is intentionally designed to ensure that traffic signals will seldom be justified on the collision justification alone. Engineering judgment should be applied to assess whether signal use may even increase the intersection collision rate due to rear-end collisions, etc., caused directly or indirectly by the signal operation.

Analysis methods that assess the expected collision performance of a location following signalization are available, and can be used to assist with the determination of the net safety change that can be expected to occur after a signal installation. Details of this procedure are included in section 4.13.

4.9 Justification 6 – Pedestrian Volume and Delay

Once justification has been established, determination of the appropriate crossing protection device should be subject to site-specific engineering judgement (see Guideline 3 for options).

Purpose

The minimum pedestrian volume conditions are intended for applications where the traffic volume on a main road is so heavy that pedestrians experience excessive delay or hazard in crossing the main road, or where high pedestrian crossing volumes produce the likelihood of such delays.

The justification is applicable to an unsignalized intersection or a mid-block location.

Standard

The need for a traffic control device at an intersection or mid-block location must be considered if both the following minimum pedestrian volume and delay criteria are met:

1. The total eight-hour pedestrian volume crossing the main road at an intersection or mid-block location during the highest eight hours of pedestrian traffic fulfils the

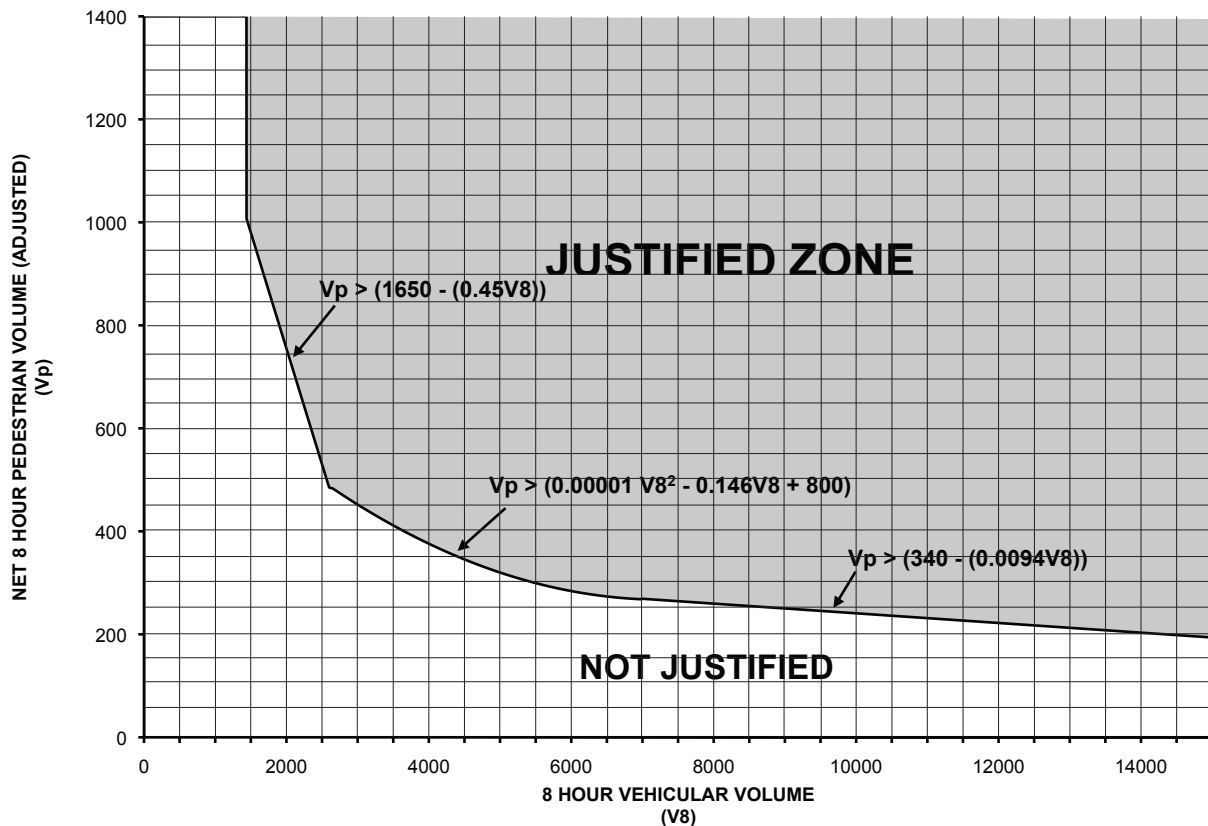

Figure 22 – Justification 6 – Pedestrian Volume

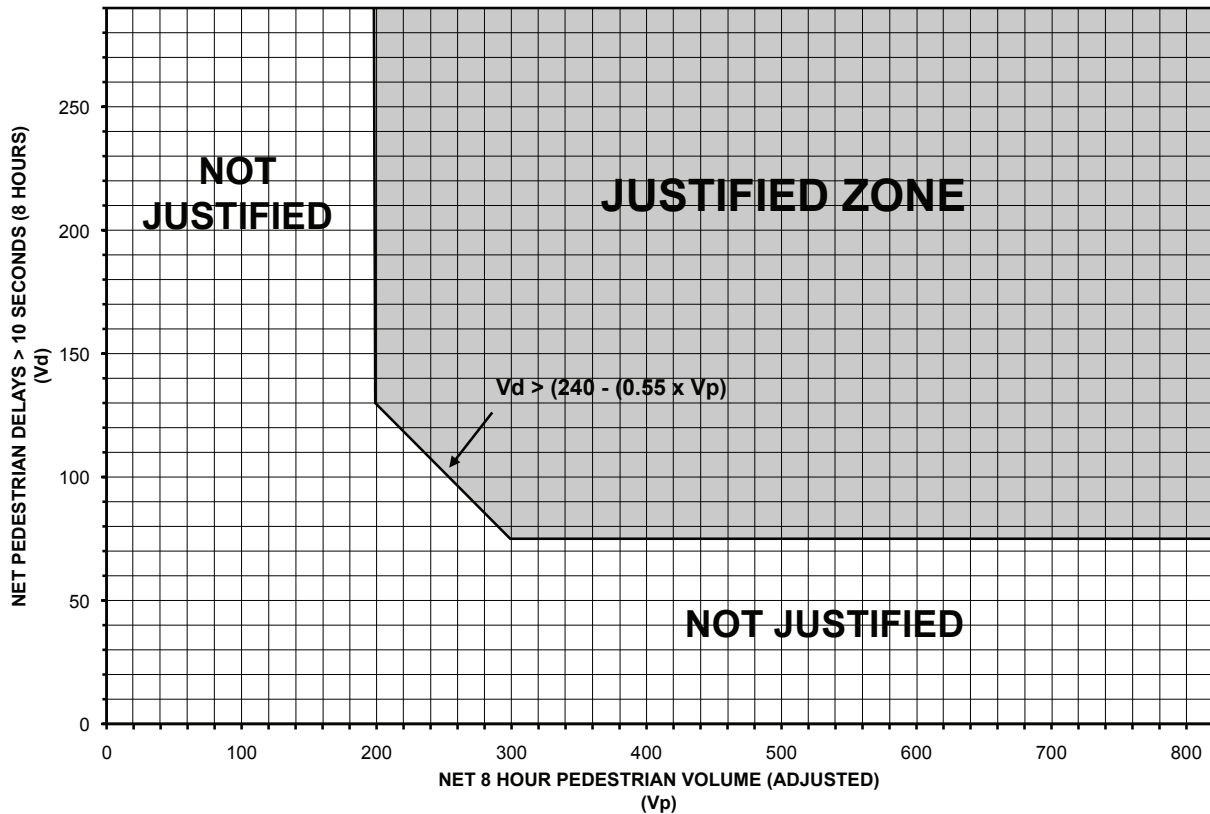

Figure 23 – Justification 6 – Pedestrian Delay

justification requirement identified in Figure 22. A tabular form of the justification values is provided in Table 18.

2. The total 8-hour volume of pedestrians experiencing delays of ten seconds or more in crossing the road during the highest eight hours of pedestrian traffic fulfils the justification requirement identified in Figure 23. A tabular form of the justification values is provided in Table 19.

Guidelines

1. If a roadway is crossed by pedestrians at several locations, and the introduction of a signal-protected crossing is likely to

consolidate the crossings at a single point, the road segment may be divided into zones, with an appropriate proportion of crossings in each zone reassigned to the signal-protected crossing zone included in Tables 16 and 17.

2. In the case of a divided roadway with a raised median at least 1.2 m wide, the justification may be calculated separately for each side. The “worst case” will govern the outcome: such that if a protected crossing is justified for one side, the entire crossing will be justified.
3. If both Justification 6 and a traffic engineering study determine that protection of pedestrian traffic crossing a roadway is appropriate, consideration may be given to the variety of options. Consistent municipal practice

Table 16 – Pedestrian Volume Data Summary

	ZONE 1		ZONE 2 (if needed)		ZONE 3 (if needed)		ZONE 4 (if needed)		TOTAL
	ASSISTED*	UNASSISTED	ASSISTED	UNASSISTED	ASSISTED	UNASSISTED	ASSISTED	UNASSISTED	
8 HOUR PED. VOLUME COUNT									
FACTORED 8 HOUR PED. VOLUME									
% ASSIGNED TO CROSSING RATE***									
NET 8 HOUR PEDESTRIAN VOLUME AT CROSSING									
NET 8 HOUR VEHICULAR VOLUME ON STREET BEING CROSSED									

- * Assisted = senior citizens, disabled pedestrians and children under 12 assisted in crossing road (Refer to Section 4.2)
- ** Factored volume = unassisted + (2 x assisted)
- *** See guideline 1 of Justification 6

Table 17 – Pedestrian Delay Data Summary

	ZONE 1		ZONE 2 (if needed)		ZONE 3 (if needed)		ZONE 4 (if needed)		TOTAL
	ASSISTED*	UNASSISTED	ASSISTED	UNASSISTED	ASSISTED	UNASSISTED	ASSISTED	UNASSISTED	
8 HOUR TOTAL OF PEDS.									
8 HOUR TOTAL OF PEDS. Delayed > 10 SECONDS									
FACTORED VOLUME** OF TOTAL PEDS.									
FACTORED VOLUME OF DELAYED PEDS.									
% ASSIGNED TO CROSSING RATE***									
NET 8 HOUR VOLUME OF TOTAL PEDESTRIANS									
NET 8 HOUR VOLUME OF DELAYED PEDESTRIANS									

- * Assisted = senior citizens, disabled pedestrians and children under 12 assisted in crossing road (Refer to Section 4.2)
- ** Factored volume = unassisted + (2 x assisted) volume
- *** See guideline 1 of Justification 6

is desirable for pedestrian crossing types, application thresholds, and crossing design. Consistency promotes motorist familiarity with the pedestrian crossing, and helps to prevent motorists from running the signal or making other unsafe maneuvers. Unique or limited application of pedestrian crossing types not typically used in a jurisdiction should be avoided.

Pedestrian crossing protection devices include:

- a) *Intersection Pedestrian Signals (IPS).*
If the pedestrian crossing is at an intersection, the decision should be based on fulfilment of Justification 6, but the crossing vehicular traffic should be so light

that it does not meet one of the other justifications (1 through 4).

- b) *Pedestrian Crossovers (PXOs).*
Pedestrian Crossovers are intended for low to moderate volume, low speed roadways (60 km/h or less posted speed), and must not be used where the road volume exceeds 35,000 AADT. PXOs should not be installed at sites where there are heavy volumes of turning traffic, or where there are more than four lanes of two-way traffic or three lanes of one-way traffic. PXOs should not be within 200 m of other signal-protected pedestrian crossings. Parking and other sight obstructions should be prohibited within at least 30 m

of the crossings. Regulation 615 of the HTA covers most aspects of required PXO traffic control devices and their placement. Justification for PXOs should be based on the above factors plus an adjusted threshold for Tables 18 and 19 which is set by the authority.

c) Midblock Pedestrian Signals.

Midblock pedestrian signals should be restricted to roadways posted at less than 80 km/h. Justification for midblock pedestrian signals should be based on a percent justification, as given in Figures 22 and 23, which is set by the authority as the required threshold.

d) Full Intersection Signals.

Consideration should be given to implementing a full traffic signal at an intersection in the case where pedestrian crossing protection is justified but either:

- A PXO, IPS or midblock device is inappropriate because of the roadway physical or operating conditions as noted in (a) or (c) above.
- An IPS is justified but is not in the preferred traffic control device within the municipality. In such cases, it is desirable that at least one of the justifications 1, 2 or 3 is met 80% or more in addition to justification 5 being met.

Signal Justification:

Both Justification 6A (volume) and Justification 6B (delay) met?

___ YES = Traffic Control Justified ___ NO = Traffic Control Not Justified

Table 18 – Pedestrian Volume Justification 6A

8 HOUR VEHICULAR VOLUME (V8)	NET 8 HOUR PEDESTRIAN VOLUME				
	<200	200 - 275	276 - 475	476 - 1000	>1000
<1440	NOT JUSTIFIED	NOT JUSTIFIED	NOT JUSTIFIED	NOT JUSTIFIED	NOT JUSTIFIED
1440 - 2600	NOT JUSTIFIED	NOT JUSTIFIED	NOT JUSTIFIED	SEE EQUATION 1	JUSTIFIED
2601 - 7000	NOT JUSTIFIED	NOT JUSTIFIED	SEE EQUATION 2	JUSTIFIED	JUSTIFIED
>7000	NOT JUSTIFIED	SEE EQUATION 3	JUSTIFIED	JUSTIFIED	JUSTIFIED

EQUATION 1: Justified if net 8-hour ped vol. > (1650 – (0.45V_g))

EQUATION 2: Justified if net 8-hour ped vol. > (0.00001 V_g² - 0.146V_g + 800)

EQUATION 3: Justified if net 8 hour ped vol. > (340 – (0.0094V_g))

% Justification = ((net 8 hour pedestrian volume)/(Equation 1, 2 or 3 as appropriate)) x 100%

Table 19 – Pedestrian Delay Justification 6B

NET TOTAL 8 HOUR VOL. OF TOTAL PEDESTRIANS	NET TOTAL 8 HOUR VOLUME OF DELAYED PEDESTRIANS		
	<75	75 - 130	>130
<200	NOT JUSTIFIED	NOT JUSTIFIED	NOT JUSTIFIED
200 - 300	NOT JUSTIFIED	JUSTIFIED IF VOL. OF DELAYED PEDS. > (240 - (0.55 x VOL. OF TOTAL PEDS))	JUSTIFIED
>300	NOT JUSTIFIED	JUSTIFIED	JUSTIFIED

% Justification = ((net 8 hour delayed pedestrian volume) / (threshold volume for justification)) x 100%

Table 20 presents minimum requirements for installation of traffic signals for Justification 1 to Justification 6.

Table 20 – Summary Table of Traffic Signal Justification

JUSTIFICATION	DESCRIPTION	MINIMUM REQUIREMENT FOR TWO-LANE ROADWAYS		COMPLIANCE	
		FREE FLOW	RESTRICTED FLOW	SECTIONAL %	ENTIRE %**
		OPERATING SPEED GREATER THAN OR EQUAL TO 70 km/h	OPERATING SPEED LESS THAN 70 km/h		
1. MINIMUM VEHICULAR VOLUME	A*. Vehicle Volume, All Approaches for Each of the Heaviest 8 Hours of an Average Day, and	480	720		
	B***. Vehicle Volume, Along Minor Streets for Each of the Same 8 Hours	120	170		
2. DELAY TO CROSS TRAFFIC	A*. Vehicle Volume, Major Street for Each of the Heaviest 8 Hours of an Average Day, and	480	720		
	B*. Combined Vehicle and Pedestrian Volume Crossing the Major Street for Each of the Same 8 Hours	50	75		
3. VOLUME/DELAY COMBINATIONS	The Above Justifications (1 and 2) Both Satisfied to the Extent of 80% or More	YES <input type="checkbox"/>	NO <input type="checkbox"/>		
4. MINIMUM FOUR HOUR VEHICLE VOLUME	At Plotted Point Representing Hourly Volume for Minor Approach vs. Major Approach for Four Highest Hours of an Average Day Fall above the Applicable Curve	YES <input type="checkbox"/>	NO <input type="checkbox"/>		
5. COLLISION EXPERIENCE	A. Total Reported Accidents of Types Susceptible to Correction by a Traffic Signal, per 12 Month Period Averaged Over a 36 Month Period, and	5			
	B. Adequate Trial of Less Restrictive Remedies, Where Satisfactory Observance and Enforcement Have Failed to Reduce the Number of Collisions	YES <input type="checkbox"/>	NO <input type="checkbox"/>		
6. PEDESTRIAN VOLUME AND DELAY	A. Plotted Point Representing 8 Hour Pedestrian Volume vs. 8 Hour Vehicular Volume Fall in Justified zone, and	YES <input type="checkbox"/>	NO <input type="checkbox"/>		
	B. Plotted Point Representing 8 Hour Volume of Pedestrian Experiencing Delays of 10 s or more vs. 8 Hour Pedestrian Volume Fall in Justified Zone	YES <input type="checkbox"/>	NO <input type="checkbox"/>		

Notes:

- * Vehicle Volume Warrants (1A) and (2A) for Roadways Having Two or More Moving Lanes in One Direction should be 25% Higher than Values Given Above.
- ** The Lowest Sectional Percentage Governs the Entire Warrant.
- *** For "T" Intersections, the Values for Warrant (1B) should be increased by 50%.

- e) Pedestrian Grade Separations In cases of very heavy pedestrian and traffic volumes, it may be economically viable to construct pedestrian bridges or tunnels.
4. The priority placed on implementing a new pedestrian crossing device should reflect the proximity and convenience of existing crossings; a higher priority should be placed on crossings where no reasonable alternatives exist within walking distance.

impact study, transportation planning study, environmental assessment or other similar evaluation. The preferred approach is that eight-hour volume projections are estimated as part of the engineering study and evaluated against Justifications 1, 2 or 3. It is incumbent upon the road authority to ensure that the calculation methodology is sound and is based on good data, so that there is a high level of confidence in the predicted traffic volumes.

4.10 Justification 7 – Projected Volumes

In some cases, it is desired to determine the future need for traffic signals at an existing or planned intersection. There are two basic scenarios. The first is that the intersection may exist and all that is changing is the addition of one or more developments which will add traffic to the intersection. The second is a development which will require, or be associated with, the construction of one or more new legs at an existing intersection or a completely new intersection or roadway.

For future development, especially where the intersection or road may not exist, eight-hour volumes may be difficult to obtain or predict with the necessary accuracy. If eight-hour volumes are unavailable or not considered to be of sufficient accuracy, Peak Hour Volumes (PHV) may be estimated as part of the transportation studies and reduced to Average Hourly Volumes (AHV) for comparison with traffic signal justifications for projected volumes.

The prediction of future traffic demands is based on knowledge of growth in roadway usage, growth of local traffic generators and predicted traffic volumes, obtained from a traffic

Table 21 – Justification 7 – Projected Volumes

Justification	Description	Minimum Requirement 1 Lane Highways		Minimum Requirement 2 or more lanes		Compliance		
		Free Flow	Restr. Flow	Free Flow	Restr. Flow	Sectional		Entire %
						Numerical	%	
1. Minimum Vehicular Volume	A. Vehicle volume, all approaches (average hour)	480	720	600	900			
	B. Vehicle volume, along minor streets (average hour)	120	170	120	170			
2. Delay to cross traffic	A. Vehicle volume, major street (average hour)	480	720	600	900			
	B. Combined vehicle and pedestrian volume crossing artery from minor streets (average hour)	50	75	120	170			

*Note: For "T" intersections, these values should be increased by 50%.

The Average Hourly Volume for a typical day can be estimated from the Peak Hour Volumes using the following relationships:

$$AHV = \frac{PHV}{2} \text{ or } AHV = \frac{amPHV + pmPHV}{4}$$

Alternately, the Average Hourly Volume for the eight highest hours of an average day can be estimated from Annual Average Daily Traffic (AADT) volume using the following relationship:

$$AHV = \frac{AADT}{16}$$

Where:

AHV = Average hourly volume

AADT = Annual average daily traffic

Analysis Using Eight-hour Volumes

If eight-hour projections are available, Justifications 1, 2 or 3 should be used. For the situation of an existing intersection with new development, Justifications 1 or 2 need to be met to 100%, or Justification 3 needs to be met to 80%.

For developments where new intersections or roadways are to be built, there is more uncertainty in the volume projections as the estimate requires projections of background traffic as well as development traffic. For this reason, where new intersection or roadway construction is required, Justifications 1 or 2 must be met to 120%.

Analysis Using Average Hour Volume

In the case that the volume estimates are based on the expansion of peak hour volumes or average daily traffic, the effect on Justifications 1 or 2 of the requirement to meet the warrant for each of eight hours would be lessened by averaging. As well, increased uncertainty is introduced by estimating from as little as one hour of traffic volume. For this reason, the thresholds are raised and, for traffic signals to be considered, Justification 7 as per Table 21 is used but with a 20% increase over the required volumes for an existing intersection and a 50% increase for a future intersection or roadway. For example, under restricted flow and two lanes, the AHV for Part 1A of Justification 7 must be met to $900 \times 1.20 = 1080$ vph.

Note that future volumes may include side street traffic attracted to the new traffic signal since the signal may provide a significant reduction in delay.

Table 22 – Future Development: Volume Expansion Required to Meet Justifications

Roadway Condition	Full Eight-hour Count Estimate Available		AHV Only Available
	Justification 1 or 2	Justification 3	Justification 7
Both Intersecting Roads Exist; Development is Future	100%	80%	120%
One Road, Both Roads and/or Intersection are Future; Development is Future	120%	N/A	150%

It is recommended that necessary underground provisions (such as ductwork, pull chambers and possibly pole bases) should be constructed as part of the road works where justification of a signal is met (Refer to Section 5.4). Table 22 summarizes the options and thresholds.

4.11 Signal Installation Prioritization

Due to funding limitations or other constraints, it may not be possible to implement all signals that meet the minimum technical justification criteria network-wide. It is therefore important to understand the relative value of each candidate set of traffic signals so that effort may be directed first to the site that would provide the greatest overall benefits. The benefits are normally expressed in terms of benefit/cost ratios with safety and the movement of people and goods the prime considerations.

One approach is to examine the justification analysis for each potential location and rank the sites by the degree to which they meet each justification. This approach should ensure that the collision history is integrated into the prioritization process. A weighting may be placed on each of the justification components to assign priority. Determination of a weighting scheme is the responsibility of the road authority.

4.12 Removal of Existing Signals

If the conditions under which a signal was installed change significantly and concerns arise that the signal is no longer justified, the need may be analyzed using Justifications 1 to 6 as if the signal were a “new” installation. If, under current conditions, the signal fails to meet any of Justifications 1 to 6, then the signal should be considered a candidate for removal.

If only Justification 6, Pedestrian Volume and Delay, is met, then the installation should be reviewed to ensure that the most appropriate type of pedestrian crossing protection is used. Removal of a signal should not take place without consultation with the affected community.

Key steps that should be followed for traffic signal removal after it is determined that none of the justifications are met, and are not likely to be met for a considerable period of time, are:

- A. Determine the appropriate traffic control to be used after removal of the signal.
- B. Remove any sight-distance restrictions as necessary.
- C. If the public has not been informed through a public consultative process or formal public meeting, notify the public of the pending removal by installing an informational sign (or signs) with the legend TRAFFIC SIGNAL UNDER CONSIDERATION FOR REMOVAL (or similar) at the signalized location in a position where the sign is visible to all road users.
- D. Deactivate the signal and remove the above-ground hardware. Secure and make any underground plant safe. Add sunburst “NEW” signs along with the appropriate warning signs to indicate the new form of traffic control. Monitor the new operation and make modifications to signing if required.

4.13 Collision Experience / Safety Change Estimation

Improving traffic safety is a major goal for traffic engineers, the public and elected officials. Traffic collisions cause fatalities, injuries, property damage and highway congestion. In order to improve traffic safety, the identification of highly hazardous locations or collision-prone spots and evaluation of the effectiveness of safety improvements are essential.

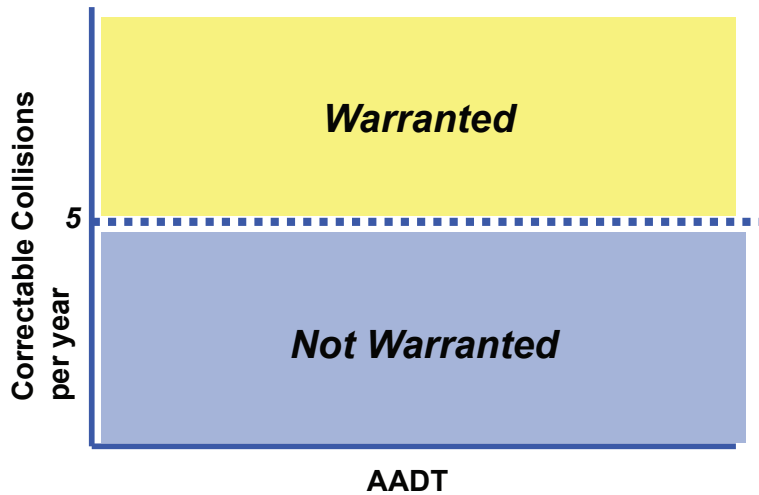

Figure 24 – Current Signal Collision Justification (Justification 5 –Section 4.8)

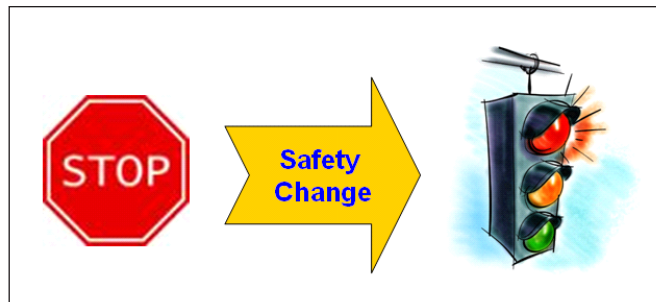

Figure 25 – General Consideration of Safety Changes

In a transportation network, intersections are relatively collision-prone locations due to the complicated conflicts between road users occurring within the intersection. A number of treatments may improve the safety and efficiency of the intersection operation. Signalizing intersections is a common treatment used by road authorities to address the safety and operation issues.

The current signal collision justification (Justification 5 – Section 4.8) for determining traffic signal installation at existing stop controlled intersections is that an intersection has had at least fifteen correctable collisions over the past three years. There are, however, limitations to this approach as it does not take into consideration

the effect of traffic volume variations in collisions. As shown in Figure 24, the number of correctable collisions that justifies signal installation remains the same regardless of the traffic volume (AADT).

Justification 5 focuses only on correctable or reducible collisions (those anticipated to be prevented following signal installation) and does not account for the non-correctable, non-reducible collisions that might increase following the installation of traffic signals. In summary, the current collision warrant may not provide a way to measure changes in safety at an intersection after installation of traffic signals. A new collision justification procedure has therefore been developed to address these potential shortcomings.

To address the issue of overall intersection safety, new collision justification procedures should examine both the safety benefits and drawbacks that can result from the installation of a signal. Conceptually, the intent is to understand the safety change that will result as the traffic control at a location changes from stop control to signal control, shown graphically in Figure 25.

The following section describes a detailed approach for estimating the safety impacts of signal installations. The approach can be used as an alternative method for examining the justification of signalization using collision experience.

Purpose

The objective of this section is to demonstrate the use of a safety analysis and evaluation tool for estimating the expected safety of installing traffic signals. The demonstration is intended to help the traffic engineer to use the analysis and evaluation tool to determine the likely safety impact of installing a traffic signal.

The proposed approach considers both the potential increase in some types of collisions and the potential decrease in others. Using the Empirical Bayes (EB) statistical analysis method, which combines the expected collision performance as indicated by Operational Performance Functions (OPFs) with the collision counts obtained from a safety database, provides an estimate of the safety effects of changing a “target” intersection from (in this case) unsignalized to signalized control.

It is critical that the expected collision performance of signalization takes into account both the recent collision history at the target location and the long-term expected collision performance of traffic signals at similar locations (in terms of traffic volume, intersection type).

Standard

The collision experience justification is based on concepts first introduced to Ontario in the Science of Highway Safety Manual²¹. The approach uses Operational Performance Functions (OPFs) to understand how collisions at similar types of locations change with traffic volume. The approach also uses Empirical Bayes (EB) statistical methods to consider the effect of the target location’s recent collision history on future outcomes. With this approach, it is possible to assess the potential change in safety that may result from installing a signal.

The Empirical Bayes method is a statistical approach for determining the appropriate weighting for each relevant factor that affects the estimate of collision outcomes for the location. The EB method determines a “smoothed” value for the number of expected collisions (obtained from the OPFs) and eliminates the randomness element in the number of recorded collisions. If the random element is ignored, regression to the mean bias may result.

OPFs detail the relationship between collisions and traffic volume. The first step is to consider what the collision behaviour will be if a signal is not installed. The predicted number of collisions for the general type of intersection being investigated is obtained from OPFs and combined with the historical collision counts for the particular intersection to determine the expected number of collisions for that particular intersection if it remains unsignalized. The next step is to examine what the collision behaviour will be if signals are installed.

For traffic signals, it is important to examine two distinct groups of intersection collisions: Reducible collisions and Non-Reducible collisions. Reducible collisions are the types of collisions deemed susceptible to reduction following a signal installation. Angle and Turning Movement collisions are considered reducible collisions. These categories include both vehicle-vehicle and vehicle-

Table 23 – Collision Groups for Calibration of OPF

Reducible Collisions (RC)	Non-reducible Collisions (NRC)
Angle	Side-swipe
	Rear-end
Turning-Movement	Approaching
	Other

pedestrian collisions. Non-reducible collisions are the types of collisions that are likely to be reduced by a signal installation. They include side-swipe, rear-end and approaching collisions. The reducible and non-reducible collisions are shown in Table 23.

To examine the effect of installing a signal, it is necessary to look at reducible collisions and non-reducible collisions separately, assessing what will happen to each group as a result of installing the signal. This is because the change in outcome following signalization is different for each group. The net change in safety, looking at both potential benefits and drawbacks can be measured, and a decision to signalize, as it relates to safety, can then be determined. Figure 26 displays this concept graphically.

To develop the collision experience justification for each collision type, OPFs for unsignalized intersections (representing the before periods) and OPFs for signalized intersections (representing the after periods) were developed for both reducible and non-reducible collisions. The database used for the development of the OPFs was obtained from Ontario’s Ministry of Transportation (MTO). The database integrates the crash, intersection configurations, and traffic volume data from all intersections in the MTO’s Central and Southwest regions for the six-year period from 1998 to 2003.

To complete the collision experience justification, the unsignalized OPFs for reducible collisions obtained from intersections to the characteristics of the target intersection are used to predict the expected numbers of collisions for the target intersection. Then the expected number of collisions

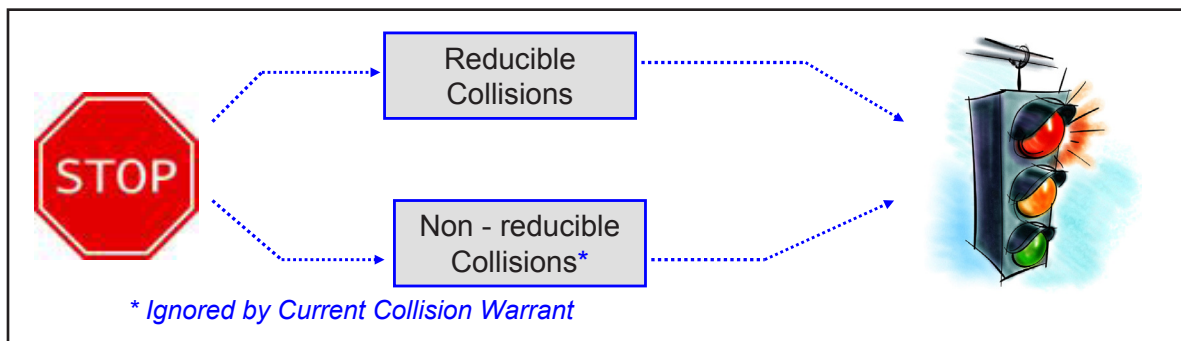

Figure 26 – Detailed Consideration of Safety Changes

(the point on the OPF for unsignalized intersections in Figure 27) and the observed number of collisions are used to determine the “smoothed” collisions for the target intersection by using the EB method.

In the next step, the signalized OPFs for reducible collisions obtained from intersections with similar characteristics are used to predict the expected numbers of collisions for an intersection with similar characteristics if the intersection were to be signalized.

Then the expected collisions for the signalized intersection with a “smoothed” value, and the expected collisions for the unsignalized condition are used to determine the estimated number of collisions at the target intersection if the intersection were to be signalized. This estimate is shown as “Estimated Collisions, Target Intersection (Signalized)” in Figure 27.

The net change between the “smoothed” collisions in the unsignalized conditions and the estimated collisions in the signalized condition represents the safety change estimated to occur. Generally,

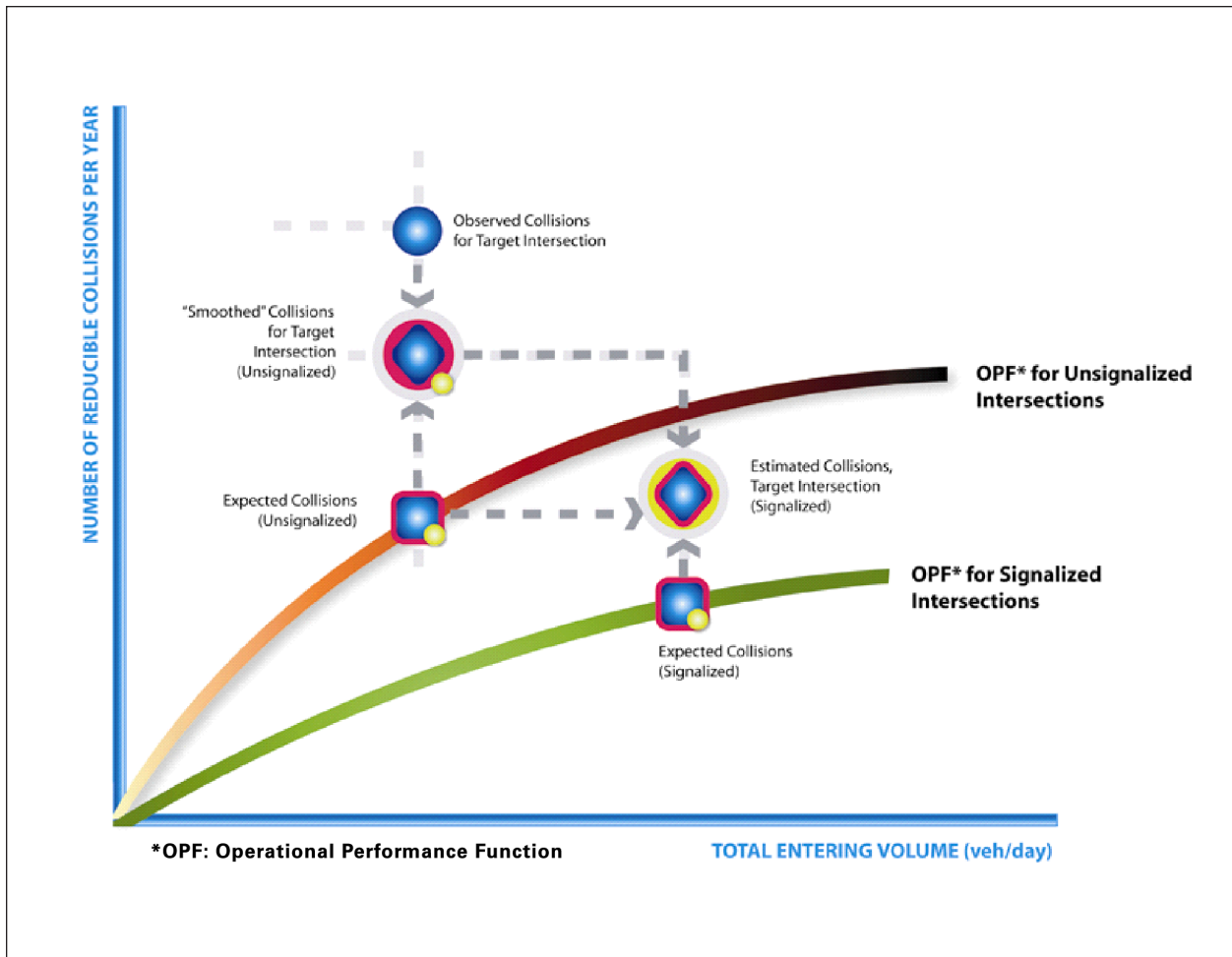

Figure 27 – Justification 5 (Alternative) – Use of Regression Relationship in the Empirical Bayes Approach for Reducible Collisions

the expected outcome for reducible collisions is a decrease in their occurrence, as shown in Figure 27.

This approach is repeated for the non-reducible collisions. The result is shown in Figure 28.

Detailed descriptions and explanations of the procedure described are available in a research paper² published by the Transportation Research Board. Users of this approach are encouraged to review the paper as it provides detailed information about the approach and the research carried out

in development and application of the approach in Ontario.

Generally, the expected outcomes of Figures 27 and 28 are a decrease in the number of reducible collisions and an increase in the number of non-reducible collisions as shown graphically in Figure 29. It must, however, be stressed that the outcome will vary because the outcome depends directly on the recent collision history and characteristics of the target intersection (or location).

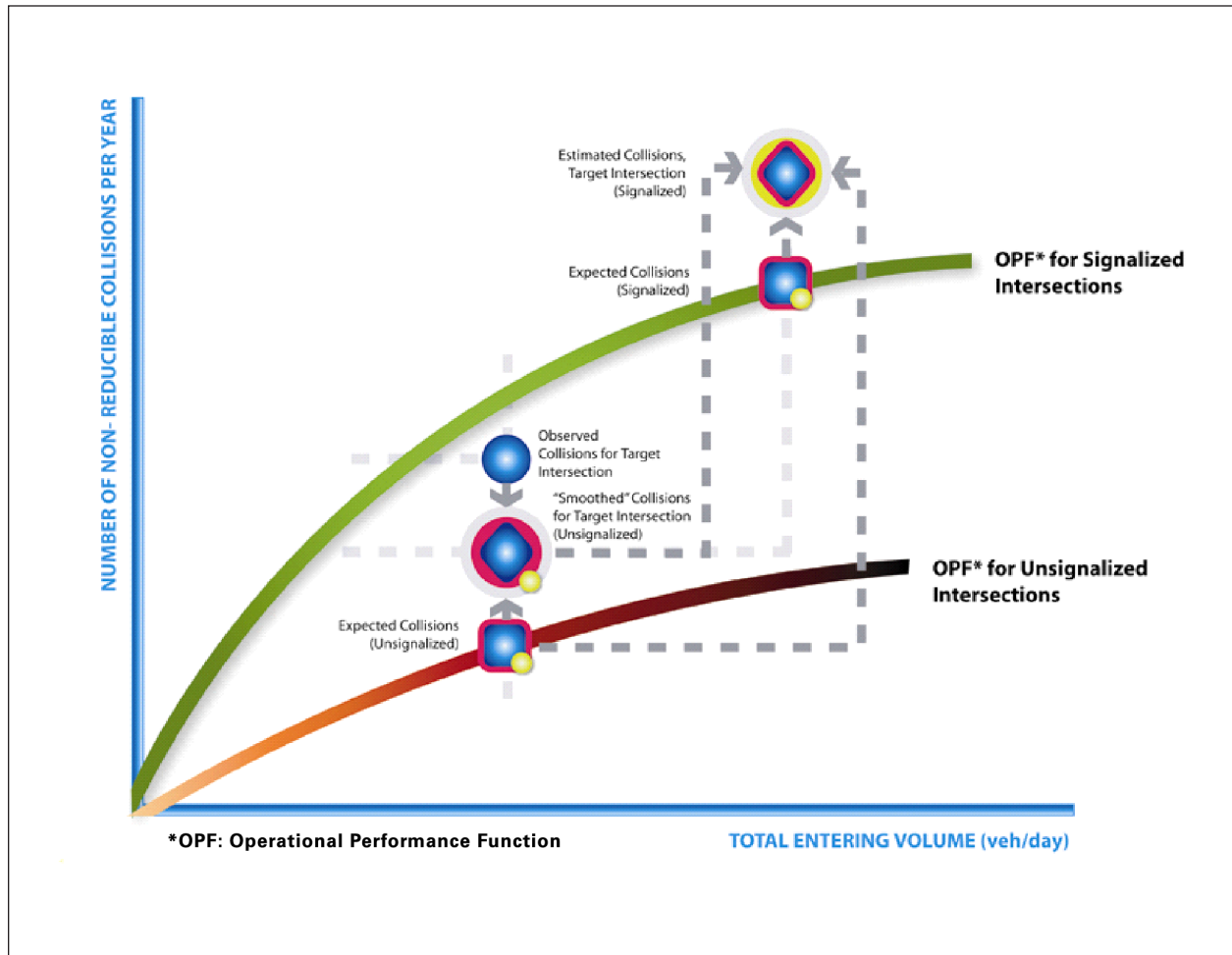

Figure 28 – Justification 5 (Alternative) – Use of Regression Relationship in the Empirical Bayes Approach for Non-Reducible Collisions

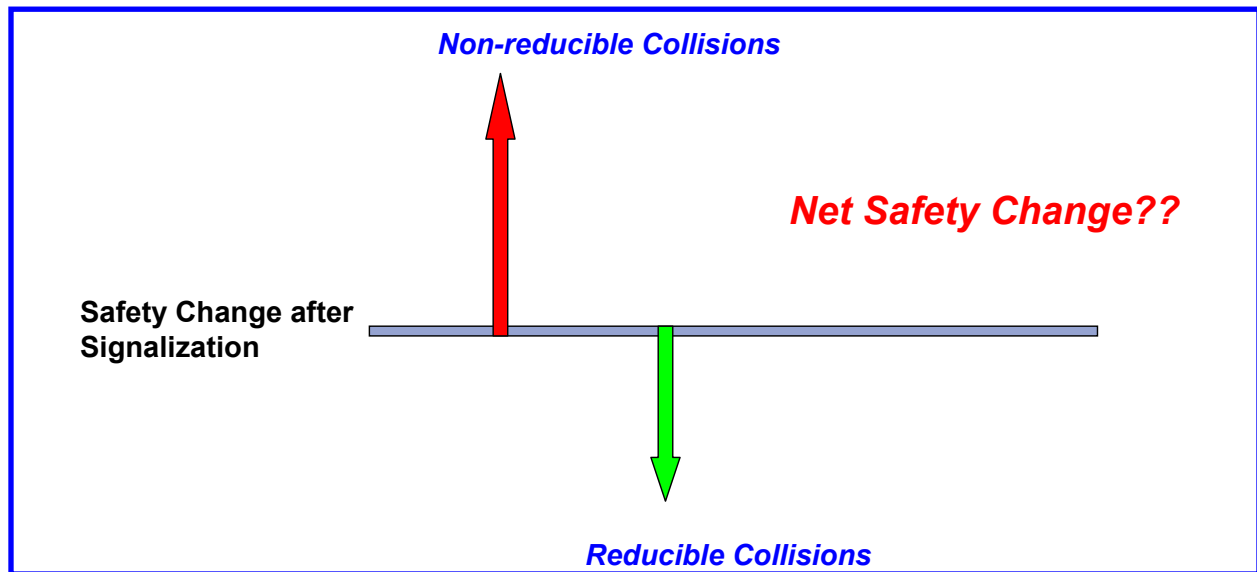

Figure 29 – Safety Changes for Reducible and Non-reducible Collisions for a Typical Case

The net safety change at the target intersection cannot be calculated simply as the difference between the two outcomes shown in Figure 29. It is important to consider the different consequences of reducible and non-reducible collision groups. Reducible collisions are generally more severe than non-reducible collisions, and this difference should be taken into account in the assessment of the net change.

Collision Severity Indexes were used to evaluate the relationship between intersection control types (signalized or unsignalized) and collision types (reducible and non-reducible). These safety indices were used to weight the number of collisions. Reducible collisions were given more weight than non-reducible collisions.

To create the indices, the database was broken down into four categories: reducible collisions at signalized intersections; non-reducible collisions at signalized intersections; reducible collisions at unsignalized intersections; and non-reducible collisions at unsignalized intersections. The number

of fatal, injury, and property damage only (PDO) collisions and total exposure (traffic volume) were assigned to each category. The relative risk method was used to estimate the probability of a collision by severity type and exposure for each collision category. Detailed descriptions of the procedure are provided in the Transportation Research Board paper². The indices derived from the MTO data set are shown in Table 24.

The safety indices for each collision estimate were used to determine a weighted relationship between the reducible and non-reducible collisions. The weighted relationship was used to determine the net safety change (NSC). Figures 30 and 31 show the result.

In Figure 30, the **positive** value of NSC indicates that it is likely that installing a traffic signal will result in a safety **deterioration** at the target intersection (as also shown in Figure 28).

In Figure 31, the **negative** value of NSC indicates that it is likely that installing a traffic signal will result

Table 24 – Collision Severity Indices derived from MTO’s Database

Collision Types	Collision Severity Index
Reducible Collision at Signalized Intersections	0.30
Non-reducible Collision at Signalized Intersections	0.25
Reducible Collision at Stop Controlled Intersections	0.27
Non-reducible Collision at Stop Controlled Intersections	0.18

in a safety **benefit** at the target intersection (as also shown in Figure 27).

To facilitate use of the Empirical Bayes approach, a Microsoft® Excel™ spreadsheet was developed to calculate the Empirical Bayes results. The spreadsheet allows users to conduct a detailed engineering study for estimating the safety impacts

of signal installations, but only requires the target location’s basic traffic data as input.

The spreadsheet consists of three sections:

1. An “Input Data” section in which the target intersection’s basic information (collision impact types and AADTs for each year of analysis) is entered manually.

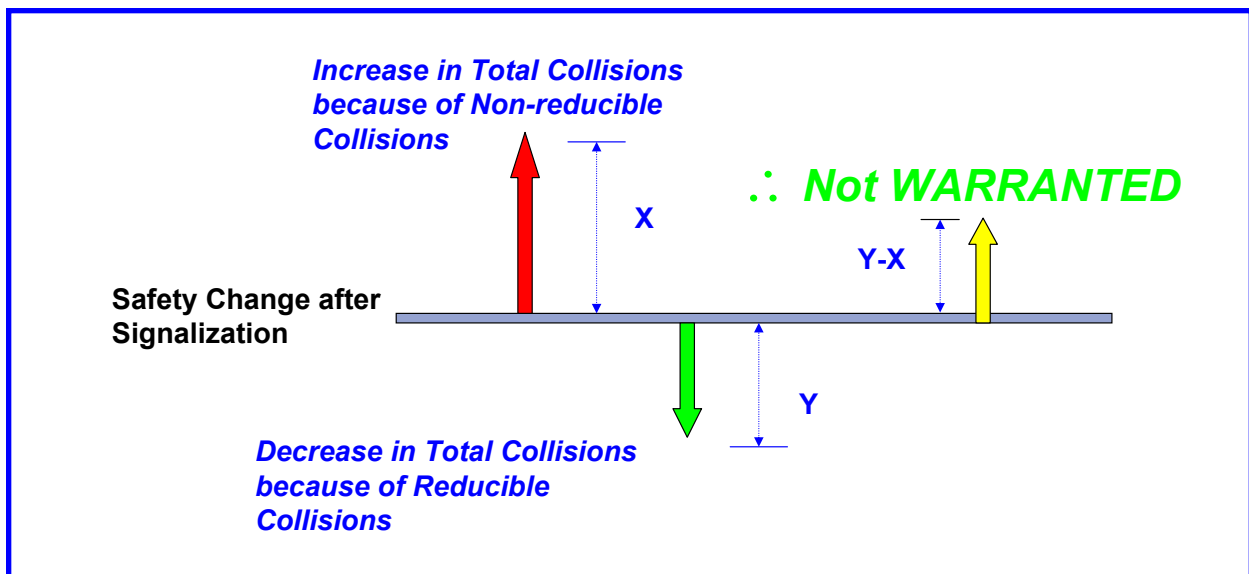

Figure 30 – Safety Deterioration Resulted from Converting an Unsignalized Intersection to a Signalized Intersection

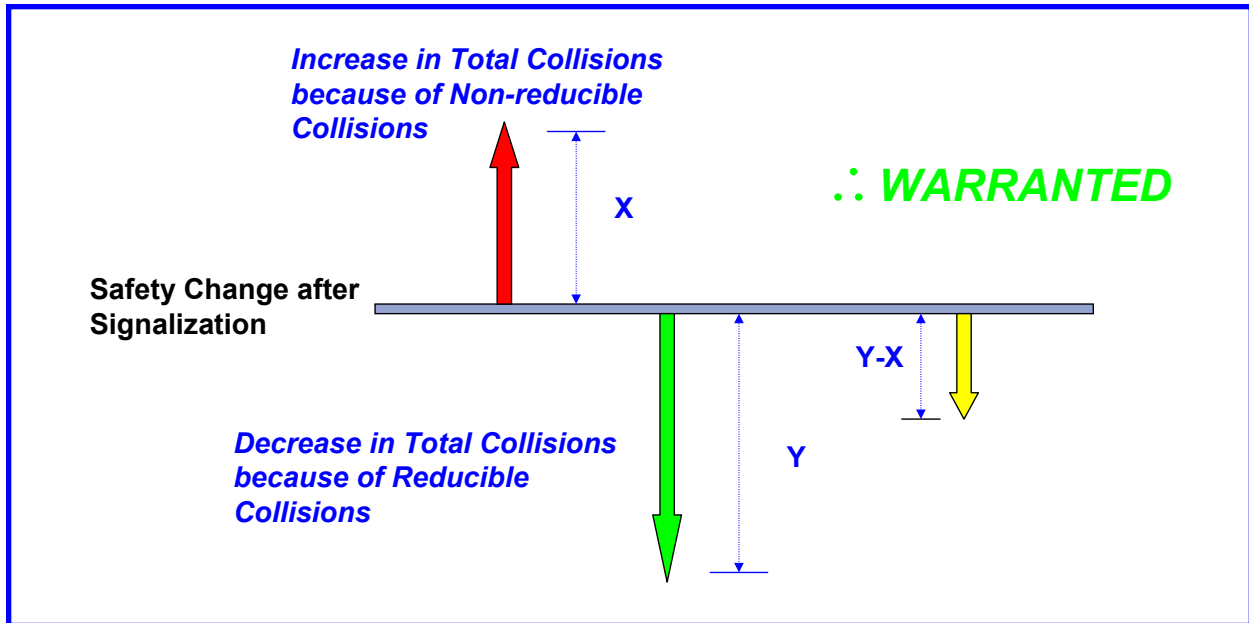

Figure 31 – Net Safety Benefit Resulted from Converting an Unsignalized Intersection to a Signalized Intersection

2. The "Analysis" section shows all the details of the analysis for both reducible and non-reducible collisions including the calculations. The calculations cannot be modified by the user.
3. The "Results" section shows the net safety change that can be achieved by installation of a traffic signal. This section cannot be modified by the user.

Guidelines

The proposed approach uses the Empirical Bayes (EB) method and collision prediction models for estimating the safety effects of unsignalized intersections that are being considered for traffic signal installation. Collision prediction models or Operational Performance Functions (OPFs) for signalized and unsignalized intersections were used to explore the relationship between the number of

collisions and traffic volume. For each collision type, models for unsignalized intersections (representing the before periods) and for signalized intersections (representing the after periods) were used to assess the expected change in overall collision performance following signalization.

As with the existing collision justification approach, less restrictive measures may be implemented before installing a traffic signal. These measures include: the improvement of control or warning signs; installation of flashing beacons; the provision of safety or channelizing islands; the improvement of street lighting, geometry or visibility; the relocation of bus stops; and/or the prohibition of parking and/or turns.

When applying the approach described in this section, the analyst must also consider the quality of information that is available, particularly the information relating to collisions.

Where “self-reporting” collision records (as opposed to at-the-scene reporting by police) are collected and used, the accuracy of the information should be closely scrutinized. Data from “self-reporting” reports may reduce the quality of the determination into whether or not the collision would be preventable by the installation of signals.

The Empirical Bayes justification provides a significant departure from the existing approach. By considering both the safety benefits and drawbacks of installing signals, it is hoped that users will be able to make more informed decisions. This alternative tool provides an assessment of the potential safety impact of installing a signal, but as with all justifications, the information must be considered in association with a full range of information and with proper engineering judgment.

4.14 Sample Calculations for Traffic Signal Justification

Calculations for the six Justifications may be conducted using an Excel™ spreadsheet. The spreadsheet consists of three sections:

1. **“Input Data”** sheet in which all the information required for calculation of the justifications is entered manually.
2. **“Analysis”** sheet that shows all the detail of the analysis for all the justifications. This spreadsheet cannot be modified by the user.
3. **“Results”** sheet that shows the results for each justification. The “percent compliance” in the spreadsheet indicates how close the intersection is to achieving the particular justification.

This section provides a numerical example for illustration purposes.

The input data, analysis, and results sheets required for traffic signal justification are shown below.

Input Data Sheet

Input Data Sheet [Analysis Sheet](#) [Results Sheet](#) [Proposed Collision](#) GO TO Justification:

What are the intersecting roadways?

What is the direction of the Main Road street? When was the data collected?

Justification 1 - 4: Volume Warrants

- a.- Number of lanes on the Main Road?
- b.- Number of lanes on the Minor Road?
- c.- How many approaches?
- d.- What is the operating environment? Population >= 10,000 AND Speed < 70 km/hr
- e.- What is the eight hour vehicle volume at the intersection? (Please fill in table below)

Hour Ending	Main Northbound Approach			Minor Eastbound Approach			Main Southbound Approach			Minor Westbound Approach			Pedestrians Crossing Main Road
	LT	TH	RT	LT	TH	RT	LT	TH	RT	LT	TH	RT	
7:00	33	132	2	2	3	3	1	411	21	5	47	1	10
8:00	55	221	3	9	5	7	6	530	32	9	58	4	10
9:00	33	222	1	12	12	16	4	521	37	9	35	5	10
10:00	7	330	3	12	10	5	6	318	9	4	3	8	10
15:00	9	309	4	9	8	12	8	339	15	9	9	3	10
16:00	13	544	11	13	21	22	7	296	11	3	18	9	10
17:00	13	557	14	26	22	42	8	371	8	3	9	9	10
18:00	9	522	5	31	61	80	2	386	12	4	6	5	10
Total	172	2,837	43	114	142	187	42	3,172	145	46	185	44	80

Justification 5: Collision Experience

Preceding Months	Number of Collisions*
1-12	4
13-24	3
25-36	4

* Include only collisions that are susceptible to correction through the installation of traffic signal control

Justification 6: Pedestrian Volume

a.- Please fill in table below summarizing total pedestrians crossing major roadway at the intersection or in proximity to the intersection (zones). Please reference Section 4.8 of the Manual for further explanation and graphical representation.

	Zone 1		Zone 2		Zone 3 (if needed)		Zone 4 (if needed)		Total
	Assisted	Unassisted	Assisted	Unassisted	Assisted	Unassisted	Assisted	Unassisted	
Total 8 hour pedestrian volume	20	80	0	15	1	5	0	0	
Factored 8 hour pedestrian volume	120		15		7		0		
% Assigned to crossing rate	100%		50%		0%		0%		
Net 8 Hour Pedestrian Volume at Crossing									128
Net 8 Hour Vehicular Volume on Street Being Crossed									6,411

b.- Please fill in table below summarizing delay to pedestrians crossing major roadway at the intersection or in proximity to the intersection (zones). Please reference Section 4.8 of the Manual for further explanation and graphical representation.

	Zone 1		Zone 2		Zone 3 (if needed)		Zone 4 (if needed)		Total
	Assisted	Unassisted	Assisted	Unassisted	Assisted	Unassisted	Assisted	Unassisted	
Total 8 hour pedestrian volume	20	80	0	15	1	5	0	0	
Total 8 hour pedestrians delayed greater than 10 seconds	10	10	1	6	2	4	0	0	
Factored volume of total pedestrians	120		15		7		0		
Factored volume of delayed pedestrians	30		8		8		0		
% Assigned to Crossing Rate	100%		50%		0%		0%		
Net 8 Hour Volume of Total Pedestrians									128
Net 8 Hour Volume of Delayed Pedestrians									34

Analysis Sheet

Justification 1: Minimum Vehicle Volumes

Restricted Flow Urban Conditions

Justification	Guidance Approach Lanes				Percentage Warrant								Total Across	Section Percent
	1 Lanes		2 or More Lanes		Hour Ending									
Flow Condition	FREE FLOW	RESTR. FLOW	FREE FLOW	RESTR. FLOW	7:00	8:00	9:00	10:00	15:00	16:00	17:00	18:00		
	<input type="checkbox"/>	<input checked="" type="checkbox"/>	<input type="checkbox"/>	<input type="checkbox"/>										
1A	480	720	600	900	661	939	907	715	734	968	1,082	1,123		
	COMPLIANCE %				92	100	100	99	100	100	100	100	791	99
1B	120	170	120	170	61	92	89	42	50	86	111	187		
	COMPLIANCE %				36	54	52	25	29	51	65	100	412	52
Restricted Flow					Both 1A and 1B 100% Fulfilled each of 8 hours								Yes <input type="checkbox"/>	No <input checked="" type="checkbox"/>
Signal Justification 1:					Lesser of 1A or 1B at least 80% fulfilled each of 8 hours								Yes <input type="checkbox"/>	No <input checked="" type="checkbox"/>

Justification 2: Delay to Cross Traffic

Restricted Flow Urban Conditions

Justification	Guidance Approach Lanes				Percentage Warrant								Total Across	Section Percent
	1 lanes		2 or More lanes		Hour Ending									
Flow Condition	FREE FLOW	RESTR. FLOW	FREE FLOW	RESTR. FLOW	7:00	8:00	9:00	10:00	15:00	16:00	17:00	18:00		
	<input type="checkbox"/>	<input checked="" type="checkbox"/>	<input type="checkbox"/>	<input type="checkbox"/>										
2A	480	720	600	900	600	847	818	673	684	882	971	936		
	COMPLIANCE %				83	100	100	93	95	100	100	100	772	96
2B	50	75	50	75	64	86	66	36	37	47	61	106		
	COMPLIANCE %				85	100	88	48	49	63	81	100	615	77
Restricted Flow					Both 2A and 2B 100% Fulfilled each of 8 hours								Yes <input type="checkbox"/>	No <input checked="" type="checkbox"/>
Signal Justification 2:					Lesser of 2A or 2B at least 80% fulfilled each of 8 hours								Yes <input type="checkbox"/>	No <input checked="" type="checkbox"/>

Justification 3: Combination

Combination Justification 1 and 2

Justification Satisfied 80% or More				Two Justifications Satisfied 80% or More	
Justification 1	Minimum Vehicular Volume	YES <input type="checkbox"/>	NO <input checked="" type="checkbox"/>	YES <input type="checkbox"/>	NO <input checked="" type="checkbox"/>
Justification 2	Delay Cross Traffic	YES <input type="checkbox"/>	NO <input checked="" type="checkbox"/>	NOT JUSTIFIED	

Justification 4: Four Hour Volume

Justification	Time Period	Total Volume of Both Approaches (Main)	Heaviest Minor Approach	Required Value	Average % Compliance	Overall % Compliance
		X	Y (actual)	Y (warrant threshold)		
Justification 4	8:00	847	71	138	51 %	70 %
	16:00	882	56	129	43 %	
	17:00	971	90	108	83 %	
	18:00	936	172	116	100 %	

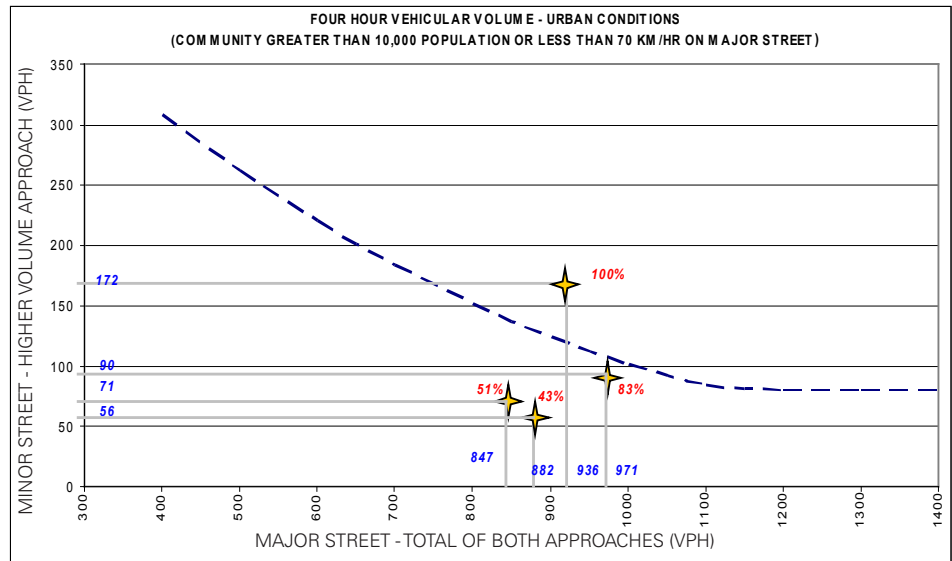

Justification 5: Collision Experience

Justification	Preceding Months	% Fulfillment	Overall % Compliance
Justification 5	1-12	80 %	73 %
	13-24	60 %	
	25-36	80 %	

Justification 6: Pedestrian Volume

Pedestrian Volume Analysis

8 Hour Vehicular Volume V_8		Net 8 Hour Pedestrian Volume				
		< 200	200 - 275	276 - 475	476 - 1000	>1000
Justification 6A	< 1440					
	1440 - 2600					
	2601 - 7000	Not Justified				
	> 7000					

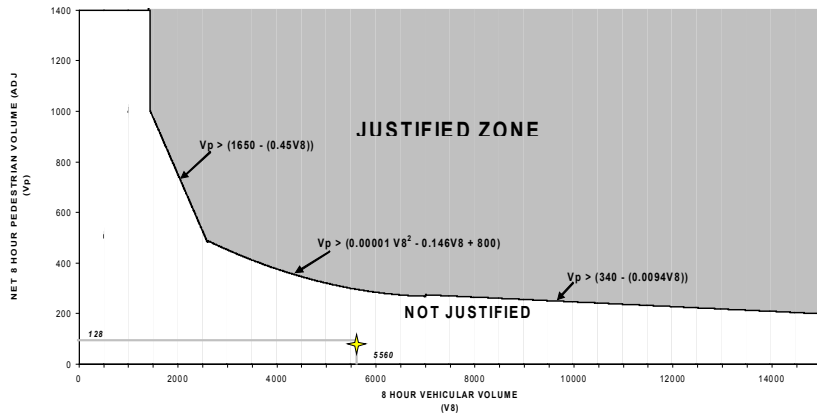

Pedestrian Delay Analysis

Net Total 8 Hour Volume of Total Pedestrians		Net Total 8 Hour Volume of Delayed Pedestrians		
		< 75	75 - 130	> 130
Justification 6B	< 200	Not Justified		
	200 - 300			
	> 300			

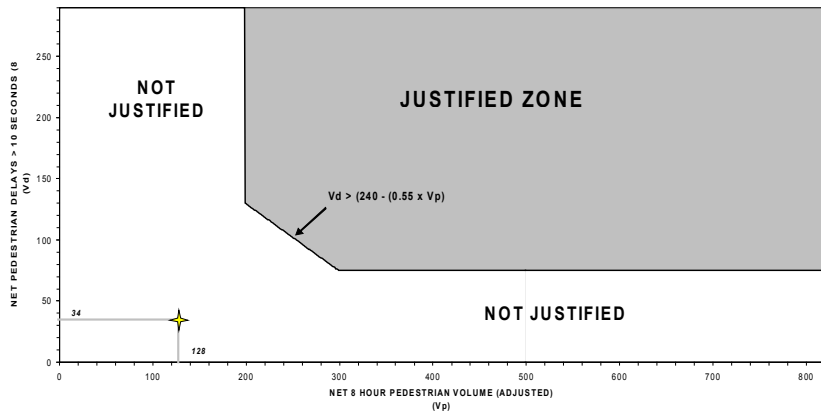

Results Sheet

Summary Results				
Justification	Compliance	Signal Justified?		
		YES	NO	
1. Minimum Vehicular Volume	A Total Volume	99 %	<input type="checkbox"/>	<input checked="" type="checkbox"/>
	B Crossing Volume	52 %	<input type="checkbox"/>	<input checked="" type="checkbox"/>
2. Delay to Cross Traffic	A Main Road	96 %	<input type="checkbox"/>	<input checked="" type="checkbox"/>
	B Crossing Road	77 %	<input type="checkbox"/>	<input checked="" type="checkbox"/>
3. Combination	A Justificaton 1	52 %	<input type="checkbox"/>	<input checked="" type="checkbox"/>
	B Justification 2	77 %	<input type="checkbox"/>	<input checked="" type="checkbox"/>
4. 4-Hr Volume		70 %	<input type="checkbox"/>	<input checked="" type="checkbox"/>
5. Collision Experience		73% %	<input type="checkbox"/>	<input checked="" type="checkbox"/>
6. Pedestrians	A Volume	Justification not met	<input type="checkbox"/>	<input checked="" type="checkbox"/>
	B Delay	Justification not met	<input type="checkbox"/>	<input checked="" type="checkbox"/>

The results of the calculation indicate that none of the six justifications are satisfied. Although Justification 1 is almost met (99% compliance), the signal is not justified at this time.

5. Design Practice

5.1 General

Use of This Section

This section of the manual is intended to provide general design interpretation, recommended practice, and guidance for the design of traffic signals. The advice of experienced practitioners should be sought for intersections with challenging configurations. In addition, each road authority may have its own specific design requirements. Designers should refer to the authority's documents for design as this section of the manual provides only general design requirements.

The design practices and guidelines given in this section have the following objectives:

- Provide a standardized basis of design throughout Ontario
- Provide instructional value to designers of Ministry and municipal traffic control systems
- Suggest standard practice details for use by municipalities that do not have standards
- Comment on some non-standard practices, conditional on the specific characteristics of the intersection and traffic
- Provide some pragmatic recommendations on the detail design of traffic control signal layouts

5.2 Practical Requirements

The responsibility of the designer is to produce a safe, effective, and efficient signal design that is acceptable to the road authority, provides

acceptable levels of service and delay to motorists and meets recognized standards. The design should also be practical. To be practical, the design should:

- Be free of utility interference
- Meet signal head visibility requirements
- Be compatible with the roadway, pavement structure, and roadside works
- Use standardized equipment
- Be readily expandable to additional phases or movements

Limitations imposed by boulevard conditions, sidewalk locations, underground and overhead utilities, etc. mean that it may not be feasible to abide by all the practices and guidelines given. In such cases, some compromise is normally necessary, and sound engineering judgement must be used to arrive at designs that follow the practices and guidelines as closely as possible.

5.3 Safety Considerations

The detailed design of traffic signals should include the following safety factors related to placement and electrical risks:

- Adequate pole offsets from the edge of the through lanes of pavement. The offsets are as related to the posted speed. The recommended practice is a 3.0 m offset. A minimum offset of 1.5 m from the face of the curb is suggested in urban areas with a posted speed of 50 km/h or less. 0.6 m is the absolute minimum for use at posted speeds of 40 or 50 km/h
- The use of pole types that meet the requirements of safety clear zones as given in the Ministry's Roadside Safety Manual²⁰ and in municipal policy manuals

- Adequate vertical clearance for traffic signal heads and overhead wiring to ensure that they are electrically safe and free from vehicle interference
- Proper ratings for fusing or circuit breakers in feeders to electrical devices
- Proper main disconnecting devices for the power to the controllers
- Proper electrical grounding of the electrical power devices, poles and equipment

The detailed requirements for the above may be found in the Ministry's Electrical Engineering Manual^{3,4} series, in municipal practice manuals, and in other referenced documents.

Other aspects of signal design, such as phasing, signal head visibility, and synchronization, affect safety with respect to collision risk. These factors are discussed in the Sections 5.5 to 5.14.

5.4 Future Considerations

The prediction of future traffic volumes is based on anticipated traffic demand. A traffic control signal Needs Report or Justification Report should be prepared. The report should address not only current traffic volume, intersection capacity, turning needs, and pedestrian needs, but also the five year horizon for such needs.

If it can be confirmed that the intersection will be upgraded within five years, the designer should inquire as to future plans for the intersection, and should incorporate any features required in the future into the current design.

Overbuilding of the traffic signals may be a waste of money if future reconstruction is anticipated. Conversely, if firm plans for future intersection geometry are available, it is advisable, where practical, to locate items such as electrical chambers and ducts in the locations required for

the future reconstruction, or, in some cases, design aerial traffic signals as an interim measure.

Where traffic control signal studies indicate that traffic control signals are not required at the current time of construction/reconstruction of the intersection, but will be required within five years, the recommended practice is to construct underground provisions in the form of ducts and electrical chambers within the current intersection upgrade. Pole footings should only be constructed where traffic at the intersection will meet the signal justification thresholds within two years.

5.5 Signal Visibility

General

Signal visibility is critical in ensuring that drivers receive timely information about the need to slow or stop. The recommended practices and guidelines given in this section should be followed as closely as possible.

Apart from geometric considerations, the visibility of signal indications is related to the following:

- Location of the signal heads and their visibility and conspicuity when illuminated
- Lamp ratings, lumen output, and age
- Reflectors and refractors
- Dirt accumulation on the optical system
- "Sun phantoms" causing lenses to appear illuminated by reflections of the sun
- Type of optical system (standard, optically programmed, LED, fibre optic)
- Size of lenses for traffic signal control

Signal Head Locations

The effectiveness of any traffic control signal installation will largely depend on the ease with which the signal heads can be seen and recognized. Signal indications should be easily noticeable. Signal conspicuity is affected by the following factors:

- Geometry of the roadway and the combined effects of horizontal and vertical alignment on vision from the intersection approaches
- Visual obstructions or distractions caused by buildings, signs, etc., adjacent to the right-of-way
- Colours of the signal heads and backboards in contrast with the colour of their background
- Placement – standardized locations assist drivers to know where to look

Signal heads for each approach to an intersection must be provided as follows:

- A minimum of two signal heads must face each approach of the intersection including public-use driveways within the intersection. At typical intersections, signal heads may be: mounted on poles with double arm brackets; suspended over the pavement on mast arms, gantry arms or structural frames; or mounted on span wire over the far side of the intersection approach.
- At the stop line, at least one, and preferably both signal heads, should be located within the drivers' cone of vision based on the driver's cone of vision extending 40° horizontally and 15° vertically from the eyes when facing straight ahead. The horizontal position of the signal head is based on the driver's cone of vision and the width of the intersecting streets. The driver has excellent lateral vision up to five degrees on each side of the centre line of the eye position (a cone of 10°), and adequate lateral vision up to 20° on each side. It is therefore desirable that at the stop line, for all approach lanes, at least one signal head be located within the 10° cone of vision with the other head

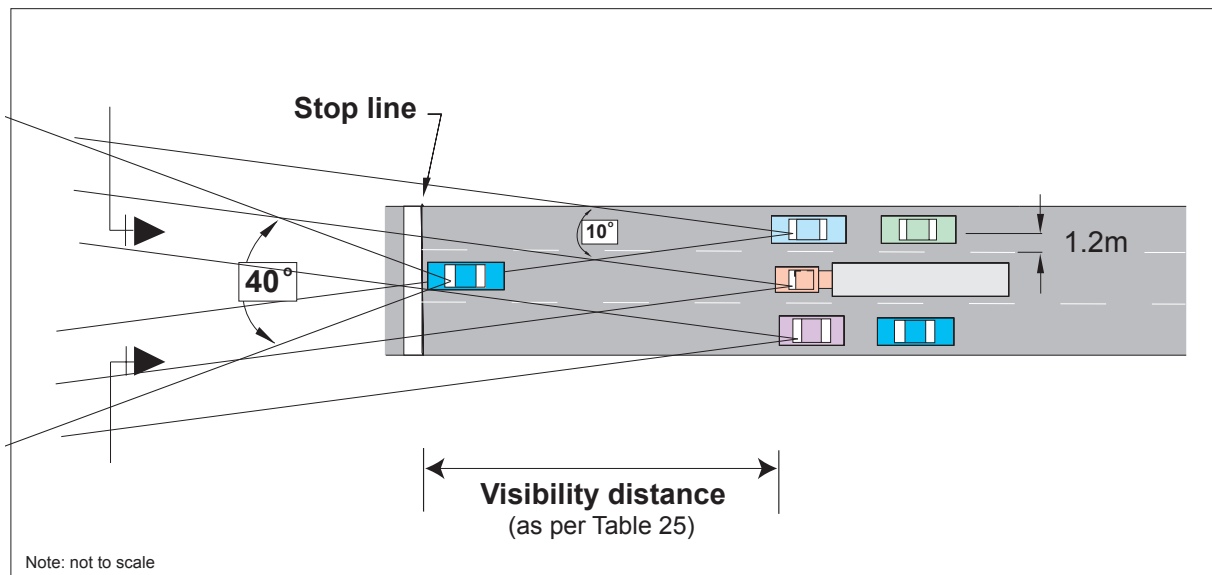

Figure 32 – Cones of Vision for Signal Visibility

located within the 40° cone of vision. While it is preferable to have the cone of vision at the stop line meet this requirement, the key location is the point where the driver is far enough away to have time to clearly see and recognize the signals before having to consider the decision to proceed or stop (see Table 25) should the signal change to amber. At this point, at least one signal head (and preferably both) must be within the 10° cone of vision for every lane, centred on the approach lanes, excluding any parking lane(s). Figure 32 shows this application of the horizontal cone of vision. Separate turn lanes should be included unless they have their own signal head. Where a signal head is intended to control a specific lane or lanes of an approach, its position should be clearly in line with the path of that movement.

- Where horizontal or vertical geometry prohibits visibility of at least one signal head within the cone of vision from the visibility distances provided in Table 25, the use of an auxiliary signal head and possibly a continuous or activated flasher with “signals ahead” sign is usually required.

Two sizes of lenses are used for traffic signal control displays: 200 mm or 300 mm nominal diameter. Where the speed limit is 80 km/h or greater, a 300 mm lens must be used for the red ball indication. Consideration should be given to using a 300 mm lens for all indications.

The 300 mm lens is also recommended for:

- All arrow indications

and at least the red signal indication for the following situations:

- Signal heads located more than 30 m from the stop line
- All intersection approaches where drivers may be confused when both traffic control and lane control signals are viewed simultaneously

- Specific problem locations such as those conflicting or competing with background light
- Where engineering studies indicate a requirement for increased visibility

Lateral Signal Head Locations

The primary signal head must be located on the far right side of the intersection. At intersections with a signal head on a median island, the primary signal head should be located laterally at least at the edge of pavement (0.5 m over the receiving lane is preferred). Where median islands do not exist, the primary signal heads should be located at the 1/2 to 3/4 point of the receiving curb lane, and at a minimum of 1.2 m into the lane. The signal head should be aimed so that it is centred on the approach.

The secondary signal head must be located on the left of approaching through lanes. The head may be placed on the median or, where there is no median, on the far left side of the intersection at least as far left as the left edge of pavement. Where intersection approaches do not align, these

Table 25 – Signal Visibility Distance

<i>85th Percentile Speed (km/h)</i>	<i>Minimum Distance from which Signal Must be Clearly Visible (m)</i>
40	65
50	85
60	110
70	135
80	165
90	200
100	230

reference points may be extended from features on the near side of the intersection.

The secondary head (far left side) should be located at or as close to the edge of the roadway as practical. Under normal conditions, there should be a minimum of 5.0 m separation between the primary and secondary head, and a maximum (desirable) lateral distance of 15.0 m between the primary and secondary head (22 m absolute maximum distance). See Section 5.6 for details.

Median Mounted Signal Heads

Signal heads mounted on median poles may be face-mounted or side mounted. Variations are necessary for signal heads with left-turn arrows and mast arms, multiple heads on a pole, or to accommodate geometric variations at the intersection.

Mounting Height

Signal head mounting heights are legally set under the Highway Traffic Act and are covered in Section 2, Legal Requirements.

Secondary heads mounted on the far left and not over traffic lanes may be mounted at a minimum height of 2.75 m for roadways posted at less than 80 km/h. For long range visibility, secondary heads for roadways posted at 80 km/h or more are preferred to be at the same height as the primary head. Where a secondary head is installed in a median island and where the left-turn lane is often blocked by large vehicles, auxiliary heads may be used on the far left of the intersection to allow better visibility. Auxiliary heads may be mounted at a minimum height of 2.75 m or as high as necessary to obtain good visibility. The desirable height in most cases is still 5.0 m. For King’s Highways and other roads posted at 80 km/h and over, all signal heads should be mounted at a 5.0 m clearance height.

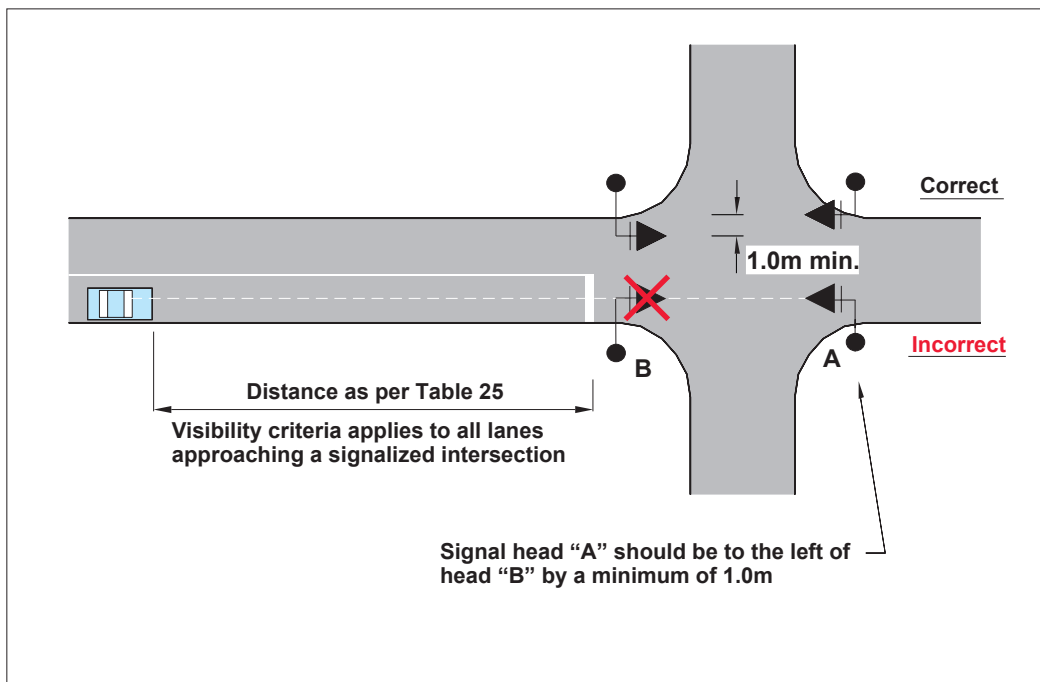

Figure 33 – Secondary Head Blocking Visibility

Obstruction by Other Signal Heads

If positioned incorrectly, the back of a signal head for the opposite direction may block part or all of the visibility of a signal for motorists approaching an intersection. Figure 33 shows how a secondary head could block visibility of the opposite primary head. The design must be checked to ensure that the near side heads are not blocking the front of the far side heads, and that at least one signal head is visible to the motorist at all times for at least the minimum distance given in Table 25. Since blockage is a function of signal head heights, intersection width, approach gradient, and lateral positioning, a field check of these requirements is strongly recommended following installation.

Backboards

Backboards improve the conspicuity of the traffic signal head and the signal display. Backboards are recommended for all primary heads and are preferred on all heads. Table 26 sets out typical uses for signal heads and backboards.

Under most conditions, backboard faces must be traffic yellow in colour. Dark colours such as dark green or black may be used to enhance the visibility and conspicuity of the backboard faces where current policies dictate certain specific conditions, or where the dark colour improves visibility and conspicuity.

On the rear surfaces, standard traffic yellow is used in most situations, but municipalities may prefer to

Table 26 – Typical Use of Signal Heads and Backboards

Type of Roadway	Signal Heads and Backboards				
	Posted Speed (km/h)	Signal Head	Type of Head	Backboard	Recommended Mounting Height (m)
Major Roadway (four or more lanes)	80 and over	Primary	Highway	Yes	5
		Secondary	Highway	Yes	5
	60 to 80	Primary	Highway	Yes	5
		Secondary	Highway	Yes	5
	Less than 60	Primary	Highway	Yes	5
		Secondary	Highway	Yes	2.75*
		Standard	Optional		
Major Roadway (less than four lanes)	80 and over	Primary	Highway	Yes	5
		Secondary	Highway	Yes	5
	60 to 80	Primary	Highway	Yes	5
		Secondary	Highway or Standard	Yes	5
	Less than 60	Primary	Highway	Yes	5
		Secondary	Highway	Yes	2.75*
		Standard	Optional		

*Note: Secondary heads mounted on the far left and not over traffic lanes may be mounted at a minimum height of 2.75m.

apply black or grey as long as the corresponding signal head housings are of the same colour and as long as the application is consistent for any particular intersection.

heads, signs, buildings infringing on a zone of restricted right-of-way, large vehicles, or other objects.

Auxiliary Signal Heads and Beacons

General

Signal heads may be obstructed by bridges (where close to an intersection), horizontal roadway curvature, vertical roadway curvature, other signal

Auxiliary signal heads are installed to augment the primary signal head, and therefore **auxiliary signal heads must display the same indications and have the same timing as the primary and/or secondary heads**. Auxiliary heads, or active or continuous “signals ahead” flasher signs, should be used whenever the traffic signal visibility distance given in Table 25 cannot be obtained. The location of the auxiliary heads themselves must comply with

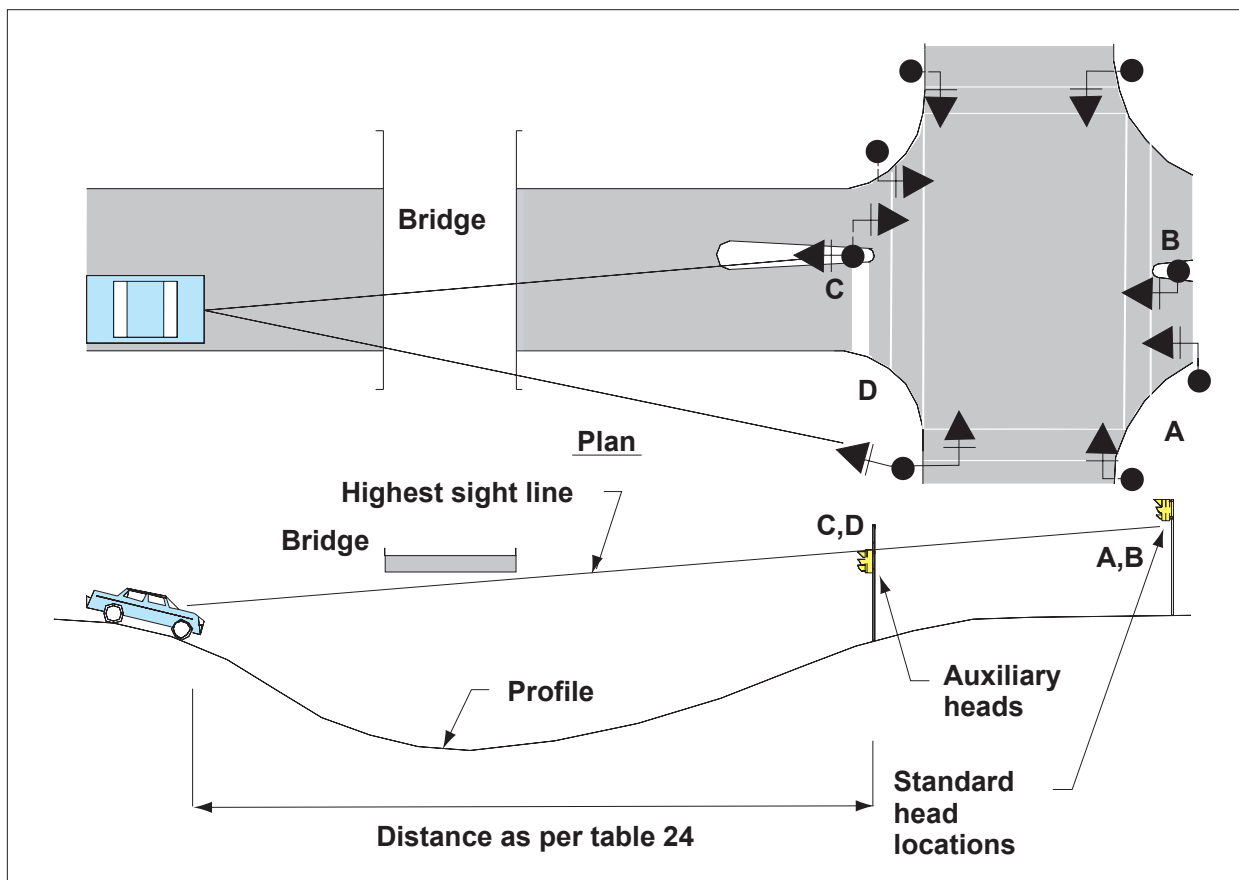

Figure 34 – Auxiliary Heads at Underpass

the visibility distance given Table 25 or the “signals ahead” flasher signs must be used.

The designer must check each design carefully, recognize sight line limitations, eliminate obstructions, and optimize the design to provide drivers with the best possible visibility.

Auxiliary Heads at Bridge Obstructions

Where normal signal head visibility may be obstructed by a bridge underpass, low mounted auxiliary heads may be required. An example is shown in Figure 34.

Auxiliary Heads at Geometric Curve Obstructions

Special considerations may be required to achieve signal visibility on horizontal curves. Auxiliary heads may be required on the near side of the intersection, either on the outside of the curve or on the rear of the median pole, as shown on Figure 35.

Two auxiliary heads on the outside of a curve should be avoided because drivers may align their vehicles towards the gap between the heads (mistaking the heads for the primary and secondary traffic signal heads, especially under limited visibility conditions).

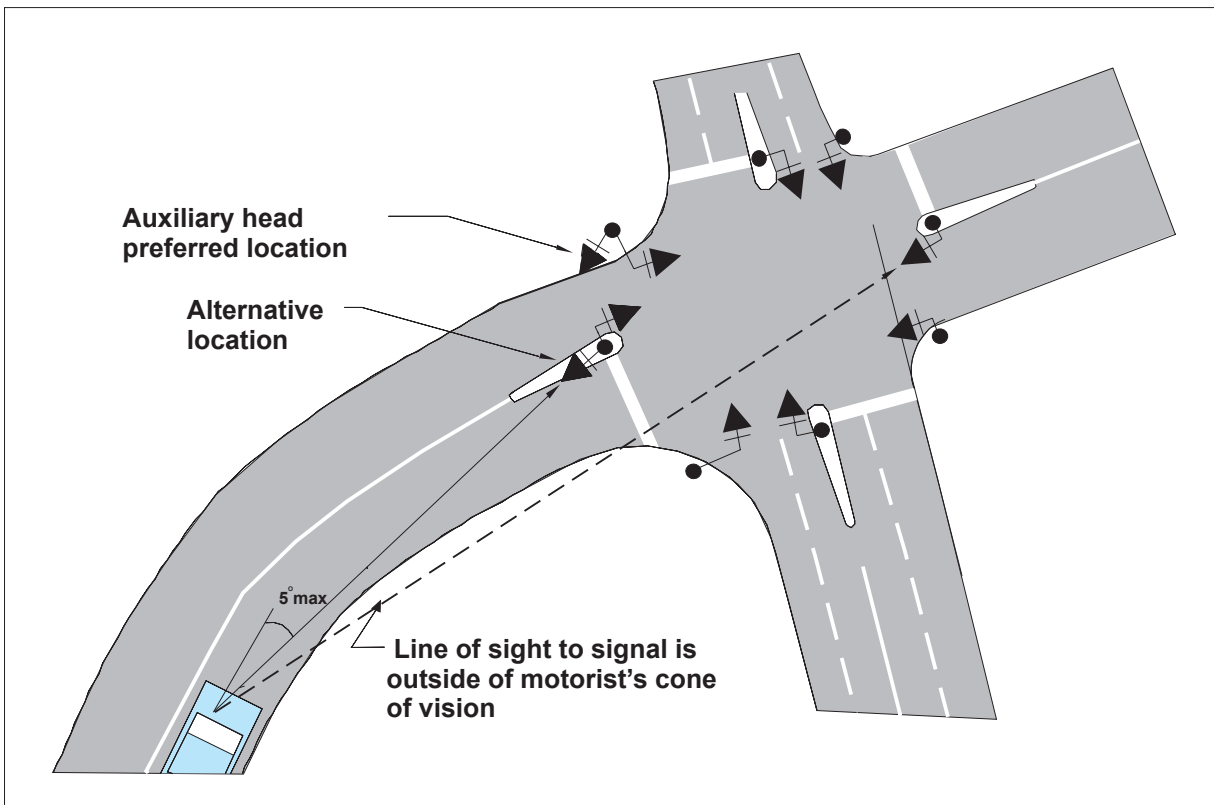

Figure 35 – Auxiliary Heads at Intersection on Curve

*Note: A maximum of one auxiliary signal head is allowed.

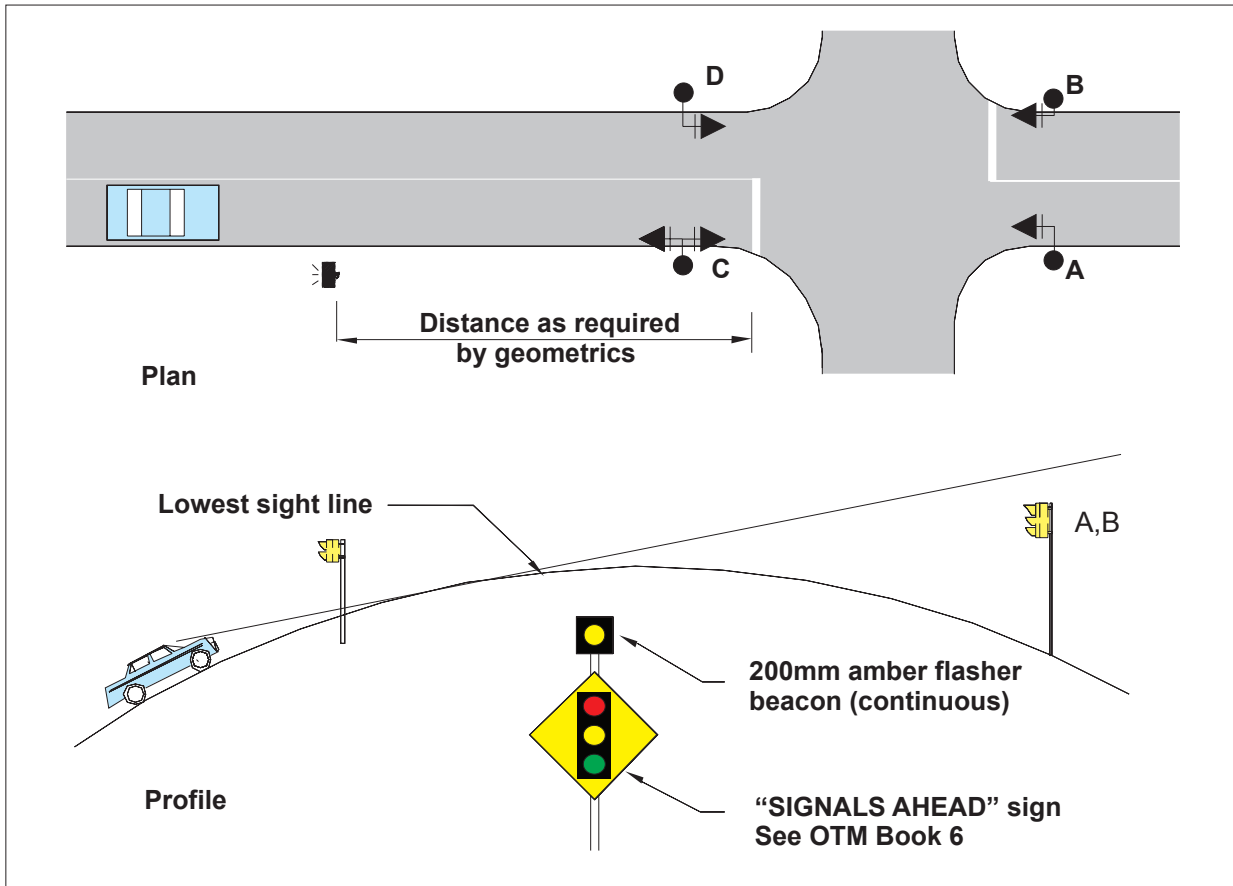

Figure 36 – Use of Continuous Flasher

Auxiliary signal heads should also be used to improve the visibility along horizontal curves where sight distance may be hampered by buildings, rock cuts, or large signs along the inside of the curve. Similarly, abrupt vertical curves that do not allow a view of the intersection pavement at the stopping sight distance may require auxiliary heads either at the intersection or at a much higher mounting height.

At locations with sight line limitations, a continuous single flashing beacon with the oversized "Signals

Ahead" sign (Wb-1102A) may be required, as shown in Figure 36.

The sign can be located upstream from the signalized intersection beyond the visibility distance shown in Table 25 and in general conformance with the signage guidelines in OTM Book 6 – Warning Signs.

An active double flashing beacon ("bouncing ball" effect) with the oversized "Signals Ahead" sign (Wb-1102A) complete with the word tab

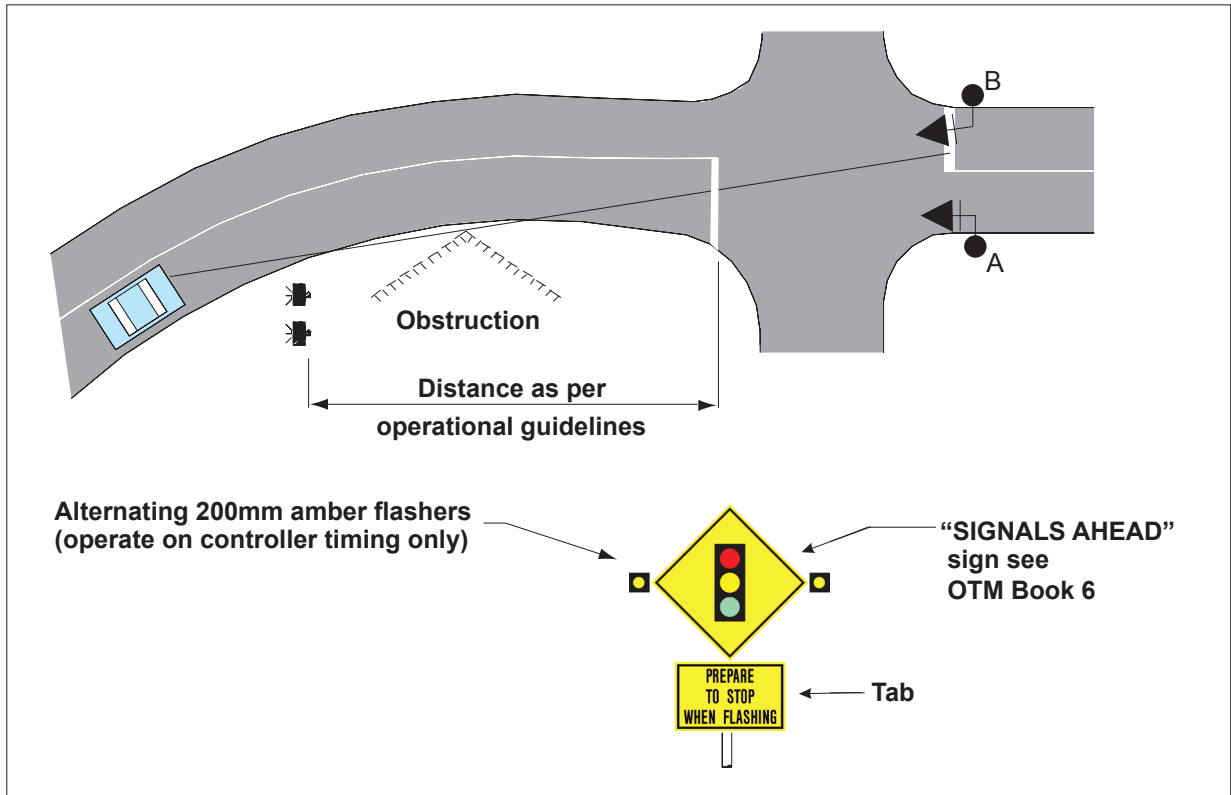

Figure 37 – Use of Active Flasher and Sign

“PREPARE TO STOP WHEN FLASHING” (Wb-102At) should be used in the following circumstances:

- Visibility is poor and the location of an auxiliary head does not suit the installation.
- There are sight restrictions at the bottom of a hill or due to a steep downgrade.

For the following situation, the active double beacon flasher may be required:

- If the signal is the first signal encountered by drivers after travelling a considerable distance on a divided highway, the signal may not be expected.

An example of a situation where an active double flashing beacon may be required is shown in Figure

37. Note that the flashing beacon and sign should operate as described in Section 3.

Obstructions due to Large Vehicles

Improper spacing between the primary and secondary signal heads may cause loss or restriction of visibility for motorists travelling directly behind large vehicles, particularly where trucks are turning left. The minimum spacing of 5.0 m between primary and secondary heads is intended to mitigate this problem to some extent. Where median islands exist, some municipalities install auxiliary secondary signal heads on the far left side of the roadway at lower mounting heights to mitigate the visibility impairment caused by large vehicles.

Optically Programmable Signal Heads

Optically programmable signal heads can be used for precise lane control. The heads project an indication that is visible only within the boundaries of a specific area.

Closely spaced, offset, or skewed intersections may require optically programmable signal heads to prevent drivers from mistakenly observing the wrong traffic signal. The heads may be used at skewed intersections with non-standard turning lanes to avoid confusion for motorists in adjacent lanes. Similarly, signal heads between two separate parallel roadways may require focused lenses to prevent confusion on the non-controlled roadway, as shown in Figure 38.

It is recommended practice to install optically programmed heads where signals need to be visible only within the boundaries of a specific area to reduce motorist confusion.

5.6 Pole and Signal Head Locations

Primary Signal Head Locations

General

In addition to the guidelines for lateral placement provided in Section 5.5, the primary heads should be located at a minimum longitudinal distance from the approach stop line of 12 m (with 15 m preferred) to a maximum of 55 m. This guideline is shown in Figure 39.

The 15 m distance corresponds to the cut-off for visibility through a normal windshield to a signal head mounted at a height of 5.0 m.

Primary heads should be located using the following guidelines:

- The recommended maximum longitudinal distance is 10 m either way from the median pole location measured along the centreline of the roadway, as shown in Figure 39.
- If the above guidelines and standard mast arm lengths allow, it is recommended that the poles be as close to the intersection as practical to allow other attachments such as secondary head mast arms and pedestrian equipment. If practical, the poles should be within 3.0 m of the centre of the crosswalks. The choice of location should take into account aesthetic requirements, utility clearances, and mast arm length restrictions. Iterative trials of the design are normally required.
- The standard 3.0 m offset from the through edge of pavement should be used. This offset is for safety purposes and must be maintained at all times for King's Highways. Where the poles are located within the turning flare area of the pavement, the offset may be reduced to 1.5 m from the back of the curbs to allow a standard 1.5 m sidewalk width between the curbs and the poles. In curbed areas with operating speeds of 40 or 50 km/h, the absolute minimum is 0.6 m. Refer to Subsection 5.3 for safety guidelines.

With Median Islands

For a straight two-lane approach with a separate left-turn lane and a median island, it is normally desirable to mount the primary head at the minimum 0.5 m overhang of the through edge of the approach curb lane in order to get as much lateral distance as practical between the primary and secondary heads. The primary head should also satisfy the cone of vision requirements shown in Figure 32 for each approach lane.

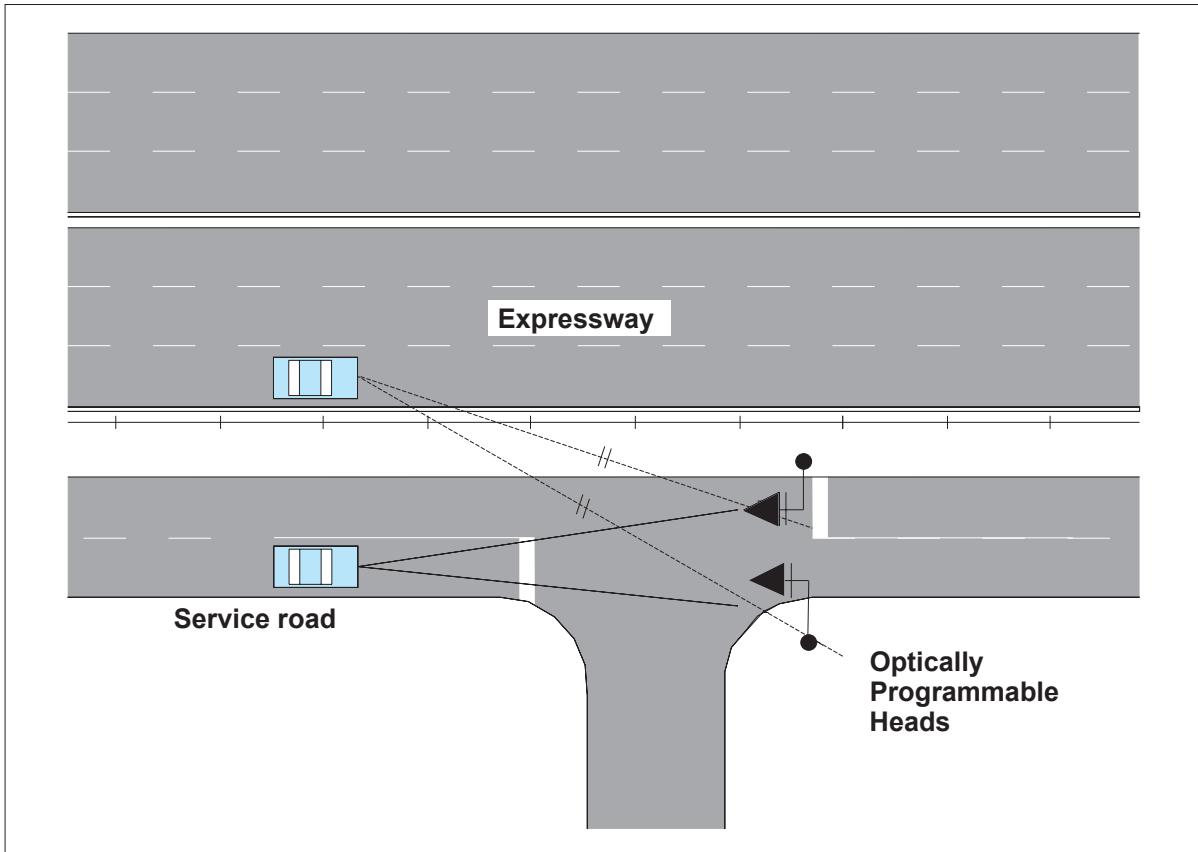

Figure 38 – Optically Programmable Heads, Example on Parallel Roads

The primary and secondary heads should be laterally separated by a minimum of 5.0 m, a desirable spacing of 15.0 m, or an absolute maximum of 22 m. The smaller spacing may result in the visibility of one of the heads being blocked by large vehicles. The larger spacing normally allows for at least one of the heads to remain within the 40° cone of vision at all times.

Without Median Islands

Where median islands are not used, it is desirable to position the primary signal head between the 1/4 point and 3/4 point of the projected through edge of the approach curb lane with the head aimed on the centre of the approach (as shown in Figure 40). The preferred position of the secondary head is over the edge of pavement on the left side. During the design, the locations of primary poles and heads are normally decided before the locations of the secondary poles.

Secondary Signal Head and Pole Locations

General

Secondary heads, other than those in median islands, should be located using the following guidelines:

- A minimum lateral distance of 5.0 m and a maximum (desirable) lateral distance of 15.0 m is required between the primary and secondary heads under normal conditions, and 22 m is the absolute maximum distance. Since the secondary heads are normally located in the flare and use the same rules as for primary heads, trial mast arm lengths are usually required during design.
- A maximum longitudinal distance of 10 m either way from the primary pole location, as measured along the centreline of the roadway, should be maintained where possible.

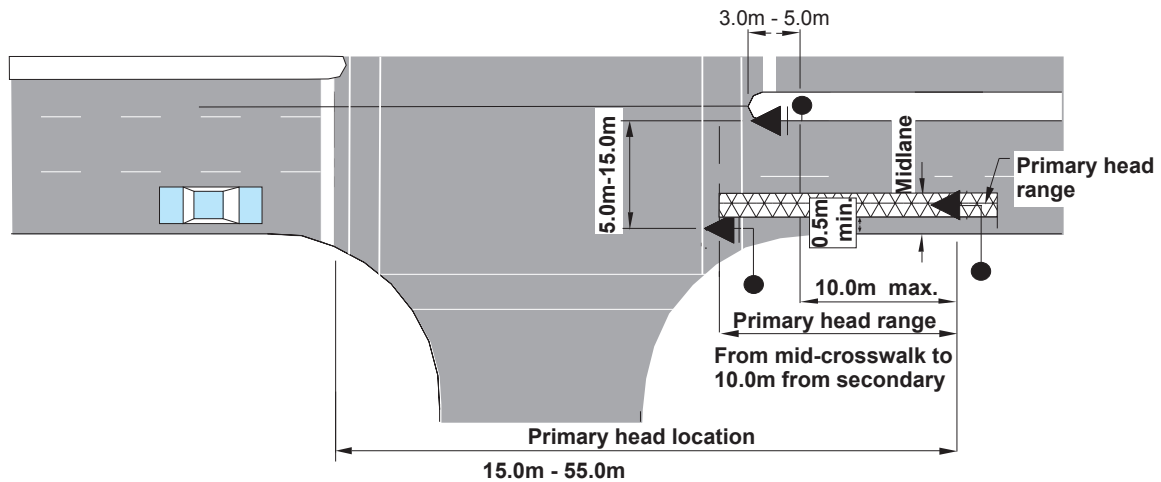

Figure 39 – Primary and Secondary Head Locations

- Secondary heads with left turn arrows should be located as near to the approach as practical.

With Median Islands

Where median islands are present (with two or more receiving lanes), primary and secondary signal heads should not be too close together laterally. Heads should not be too far apart longitudinally to avoid one head appearing to be much higher than the other from the approaching motorist's perspective.

Without Median Islands

Normally, opposing secondary heads are laterally outside of the primary heads (further from roadway centreline) by a minimum of 1.0 m, as shown in Figure 33. The preferred location for the secondary heads in this case is between 0.5 m and 0.8 m from the edge of pavement towards centreline. The secondary heads can be placed directly over the edge of pavement up to 1.5 m from the edge of pavement if necessary to meet placement criteria provided that range distances and visibility criteria are met. Figure 40 shows the range of signal head placement options.

5.7 Pedestrian Signal Heads

Pedestrian Indications

Pedestrian indications must consist of two symbols, the "lunar white" Walking Pedestrian (outline or solid) and the "translucent orange" Hand Outline.

The symbols may be contained in a single minimum 300 x 300 mm (lens) housing or in separate housings. If a single lens is used, the symbols may be superimposed over each other, or they may be offset with the hand outline on the left. If separate

housings are used, the Hand Outline section must be mounted directly above or to the left of the Walking Pedestrian section.

When illuminated, the pedestrian signals must be recognizable from a distance of 30 m under normal conditions of visibility. The flashing Hand Outline should be used in all traffic control signals as a clearance interval and warning to pedestrians that the walking time is terminating.

Guidelines for Pedestrian Signal Head Installation

In most cases, it is recommended practice to install pedestrian traffic control signals. Pedestrian traffic control signals are mandatory where it is necessary to control the sequence or length of pedestrian phases independently from vehicular phases, or where it is necessary to eliminate pedestrian confusion at approaches containing traffic control signal heads with arrows. Where one or more of the pedestrian crosswalks at an intersection justify pedestrian signals, it is usually desirable for uniformity and good observance to place pedestrian signals on all crosswalks. A pedestrian must be able to walk to any corner of an intersection. An exception occurs at a ramp terminal where it is not usual practice to have pedestrian crossings on the side of the intersection that receives left-turning traffic from the side road. It may also be desirable to ban low-volume pedestrian movements at specific locations due to large left-turn volumes. Such restrictions must be supported by proper signing as shown elsewhere in the OTM, as well as by-laws or regulations where applicable.

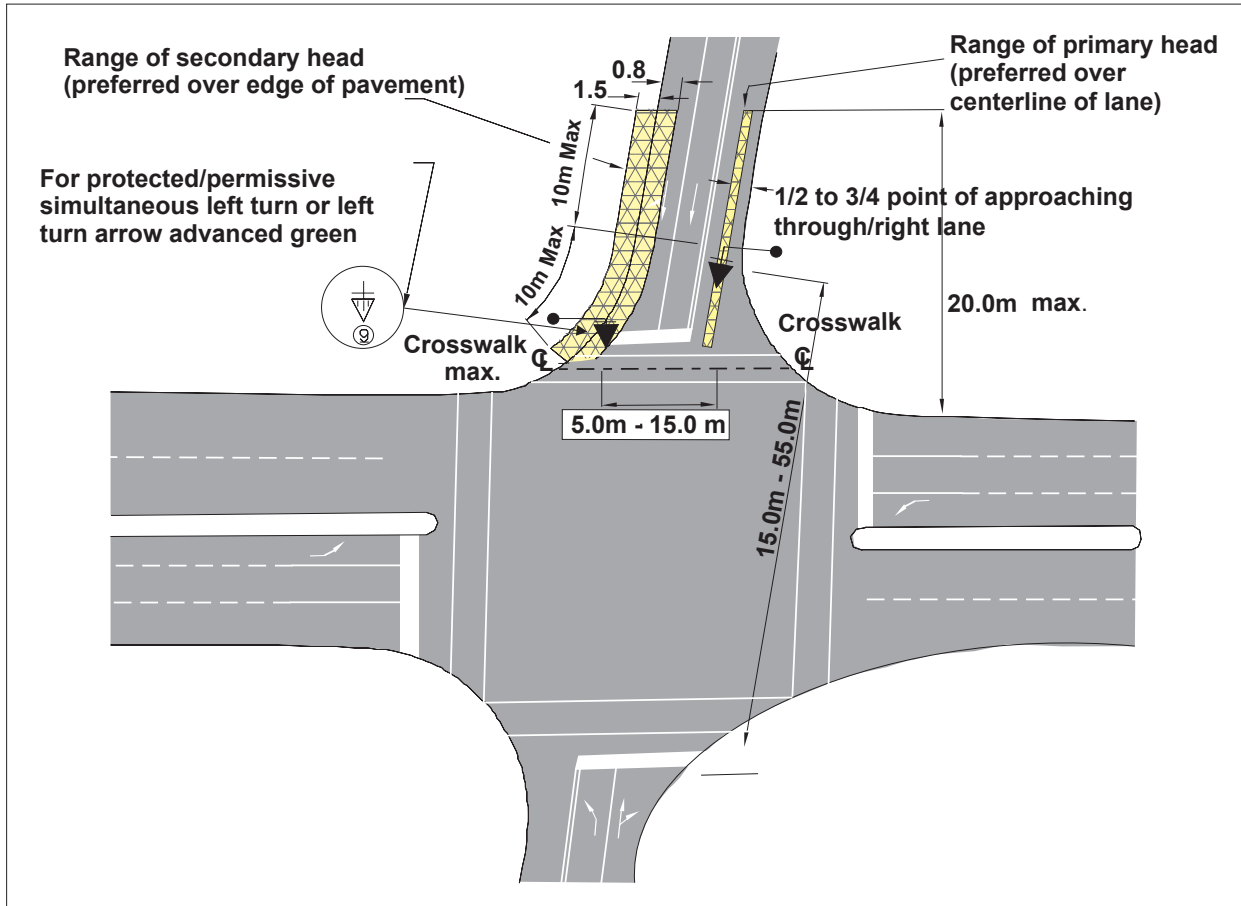

Figure 40 – Primary and Secondary Heads Without Islands

Pedestrian signal heads should be installed in conjunction with vehicular traffic control signals under any of the following conditions:

- When a traffic signal is installed under the pedestrian justification
- When pedestrians and vehicles are moving during the same phase and pedestrian clearance intervals are needed to minimize vehicle-pedestrian conflicts
- When an exclusive phase is provided or made available for pedestrian movement in one or more directions with all vehicles being stopped
- When heavy vehicular turning movements require a separate pedestrian phase for the protection and convenience of the pedestrian
- When pedestrian movement on one side of an intersection is permitted while traffic from only one approach is moving
- When an intersection is so large and complicated or a road so wide that vehicular signals would not adequately serve pedestrians

- When the minimum green intervals for vehicles at intersections with traffic-actuated controls are less than the minimum crossing time for pedestrians and pedestrian actuation is necessary (normally by pushbutton)
- When complex phasing operation would tend to confuse pedestrians guided only by traffic signal indications
- When traffic signal heads using arrows are used
- When pedestrians cross only part of the road, to or from an island, during a particular phase
- When the traffic signal heads fall outside of the normal vision of pedestrians, for example, at “T” intersections, on one-way streets, or at large intersections

Guidelines for Pedestrian Pushbuttons

Pedestrian pushbuttons are required at pedestrian actuated traffic signals. Pedestrian pushbuttons should be located using the following guidelines:

- The pushbuttons should be installed on the “through sidewalk” side of the pole at a height of 1.1 m (\pm 0.15m) above finished grade.
- The pushbuttons should be in line with the crosswalk and not perpendicular to the crosswalk. The location should be within 3.0 m of the edge of the crosswalk.
- It is desirable that a “Push Button For Walk Signal” or equivalent sign be installed at each pushbutton.

Mounting Height and Location

Pedestrian heads must be mounted at a minimum of 2.5 m as measured from finished grade at the edge of pavement to the bottom of the signal housing. This dimension should be used unless unusual circumstances require a greater height,

but pedestrian heads must not be mounted at the height of vehicle heads.

If practical, pedestrian heads should be mounted directly behind the sidewalk facing along the crosswalk. Where necessary, the heads may be mounted within 3.0 m of the edge of the sidewalk in the crosswalk-facing direction, and within 1.5 m of the edge of the crosswalk laterally. A check should be made to ensure that the pedestrian heads will not be hidden from pedestrians on the other side of the roadway by vehicles stopped at the stop line.

Accessible Pedestrian Signals

Audible or accessible pedestrian signals (APS) are designed to assist visually impaired pedestrians by providing information that they can interpret to understand when they may cross. APS devices communicate information about pedestrian timing in a non-visual format. Examples include audible tones, verbal messages, and/or vibrating surfaces coinciding with the beginning of the WALK interval.

Like visible pedestrian signals, APS devices that use audible speakers and/or vibrating hardware provide cues at both ends of a crossing when activated. APS devices that have speakers mounted in, on, or near pedestrian heads emit a sound such as a bell, buzz, tone or birdcall (typically cuckoo and chirp) during the WALK interval.

Infrared transmitters located at the pedestrian head can transmit a speech message to hand-held receivers. Messages may identify the location and direction of travel of the pedestrian, give the name of the street to be crossed, and provide real time information about WALK and DON'T WALK intervals.

A third type of APS system is fully integrated into the pedestrian pushbutton assembly. Some systems provide vibratory information only.

Others augment vibrotactile hardware with a quiet, slowly repeating, tick, click, or tone to identify the location of the pushbutton during the DON'T WALK and pedestrian clearance intervals, and a faster tick, click, or tone to identify the WALK interval.

Accessible pedestrian signals must be used in combination with pedestrian signal timing. The information provided by an accessible pedestrian signal must clearly indicate which pedestrian crossing is served by each device.

Locations that may need APS include intersections with:

- vehicular and/or pedestrian actuation
- very wide crossings
- major streets at intersections where the minor streets have very little traffic (APS may be needed for crossing the major street)
- "T"-shape
- non-rectangular or skewed crossings
- high volumes of turning vehicles
- split phase signal timing
- exclusive pedestrian phasing, especially where right-turn-on-red is permitted
- a leading pedestrian interval

Accessible indications are not covered by the HTA. Basic standards and pushbutton operation options are provided in the MUTCDC¹⁴, but at the time of publication of this edition of OTM Book 12, the MUTCDC (1998 edition) still refers to the older audible signal standard. While the MUTCDC has not yet been updated, new guidelines have been approved by TAC. Information is provided in the publication "Guidelines for Understanding, Use and Implementation of Accessible Pedestrian Signals (2008)", available from the Transportation Association of Canada (<http://www.tac-atc.ca>)

Pedestrian Countdown Displays

The pedestrian countdown display (or pedestrian countdown signal, PCS) may be added to a pedestrian signal head. The display shows a descending numerical countdown that indicates to pedestrians the number of remaining seconds available for crossing.

The Traffic Operations & Management Standing Committee (TOMSC) of TAC has developed guidelines for the optional use of pedestrian countdown displays¹². The guidelines will be added into the Manual of Uniform Traffic Control Devices for Canada in the near future. The proposed guidelines allow for the optional use of Pedestrian Countdown Displays at the discretion of signal operating agencies. More information, including the background report which supports the recommendations, can be obtained from TAC, at TIS@tac-atc.ca. The recommendations include operational guidelines and layout and configuration guidelines.

TAC Recommended Operational Guidelines

- PCS should be adopted as an optional device for installation at locations where pedestrian signal heads are installed.
- The PCS is to count down during the flashing hand pedestrian clearance period only.
- The PCS Information Sign may be installed adjacent to the pedestrian pushbuttons to inform pedestrians of the usage of the PCS.

TAC Recommended PCS Standard Layout and Configuration

- Pedestrian countdown displays should consist of Portland Orange numbers that are at least 135 mm high (220 mm lens height) on a black opaque background. The countdown

numbers should preferably be “double stroke” to improve visibility and to provide a certain amount of “fail-safe”.

- Where the pedestrian enters the crosswalk more than 30 m from the countdown pedestrian signal display, the numbers should be at least 175 mm high (305 mm lens height).
- The Pedestrian countdown displays should be of the “Separate Countdown Housing” configuration. The “Overlap/Countdown Side by Side” configuration and the “Separate Countdown Housing with no Overlap” configuration may be used in retrofit situations. The countdown pedestrian signal must be located immediately adjacent to the associated HAND pedestrian signal head indication.
- The WALK and the HAND indications must be the same as those used in the conventional pedestrian signal, and must comply with Section B1.5.4, Section B3.4 and Figure B3-9 of the MUTCDC.

5.8 Miscellaneous Traffic Control

Intersection Pedestrian Signals

Intersection Pedestrian Signals (IPS) may be installed at intersections that have considerable pedestrian volumes, but very light traffic on the side road. IPS require that a normal crosswalk pavement be marked in accordance with standardized practice for traffic signals, and that the side road be provided with stop signs (if not already provided), as shown in Figure 41.

Typical three-section signal heads are used for the main road. Pedestrian signals with pushbuttons are required for the crossing.

Signal heads may be mounted on the same poles, either back-to-back, as shown in Figure 41, or independently.

It is also possible to install the crossing on the opposite side of the side road. or to install dual crossings, one on each side. Details of the latter design approach may be found in the TAC MUTCD¹⁴.

Mid-block Pedestrian Signals

Where justified by continual disruption of traffic flow, by collision histories, or by heavy pedestrian volumes and delays, pedestrian signals may be installed at mid-block locations. The pavement markings for mid-block pedestrian crossings are similar to the markings for normal signalized intersections with the vehicle stop lines set back a minimum of 12 m from the primary signal head (15 m recommended practice). At mid-block locations, the conspicuity of the pedestrian signals to drivers is paramount. At mid-block locations, the usual cue for the presence of a cross-road, which leads motorists to expect the possibility of a signal, is missing. Section 4 gives justification criteria for the use of mid-block signals. Mid-block signals should be used in lieu of PXOs where the posted speed exceeds 60 km/h, where there are more than four lanes, or where other PXO criteria are not met.

Lane Direction Signals

Lane direction signals are normally used to change the direction of traffic flow for single lanes, multiple lanes, or the full roadway during various times of the day. A common application is characterized by a very heavy morning Peak Hourly Volume (PHV) in one direction and a similar very heavy afternoon PHV in the other direction.

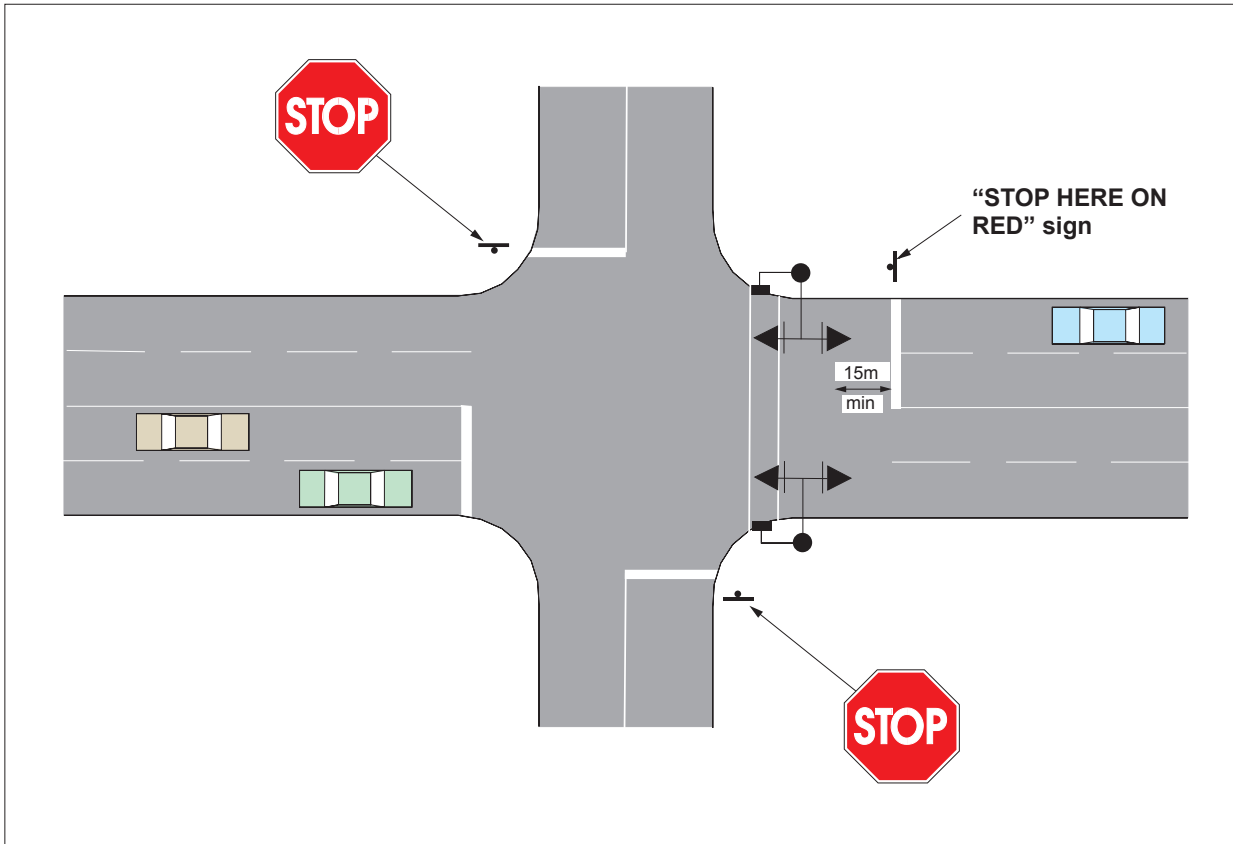

Figure 41 – Intersection Pedestrian Signals

Lane direction signals must be suspended directly over the approximate centre of the lane to which they apply. Signals for different lanes should be mounted at a uniform height and positioned so that they form a straight line and cross the roadway lanes at right angles. Each signal head must be mounted a minimum of 4.5 m over the pavement, with a 5.0 m clearance preferred.

Lane control signals must be carefully located in advance of, or beyond, an intersection controlled by standard traffic control signals in order to eliminate possible confusion between the indications. A

signal indication must always be illuminated in both directions of the lane or lanes controlled.

The signal indications consist of a red "X" and a green arrow (downwards), as shown in Figure 16 in Section 3. The layout of the lane direction signals should take visibility into account as follows:

- At least one set of indications should be visible to the motorist at all times.

- A 300 mm size lens should be used for speeds of 60 km/h or less with symbols visible up to 150 m. A 400 mm size lens should be used for operating speeds up to 80 km/h with symbols visible up to 225 m.
- Spacing of the lane direction signals should be set based on minimum visibility (approximately 150 m for 300 mm lenses, and 225 m for 400 mm lenses).
- Lane direction signals in tunnels may need to be mounted elsewhere other than over the centre of the lanes due to height restrictions.

Ramp Metering Signals

Heads for ramp metering are used on freeway entrance ramps and are governed by Regulation 626 (5) of the HTA. The primary head may be mounted at 2.75 m if not over traffic. The secondary head should be mounted at a height of 1.0 to 1.2 m to provide driver visibility since the stop line is directly beside the secondary head.

Signals Near Railway Crossings

Where railway crossings lie within the intersections themselves, special treatment of railway and highway signals must be undertaken to provide greater protection for vehicles. Examples of this are given in the TAC MUTCD¹⁴.

Where the railway crossings are so close to the intersections that back-ups from the vehicle signals may occur, the interconnection of railway and vehicle signals will be required. The interconnection allows for preemption of the vehicle signals. Preemptive signals may also be used to activate other devices (such as blank-out signs for turn prohibitions) during train crossings.

Where the railway crossings are within 150 m of the proposed signal installations, an evaluation of

probable back-ups from the signal systems must be conducted by the road authority and submitted to the appropriate railway owner for approval, coordination, and costing. This evaluation must estimate the times of day and probable duration of any back-ups likely to obstruct the crossings.

Signals that require railway interconnection should not be constructed until the approval of the railway owner has been received and cost sharing has been resolved.

Transit Priority Signals

Transit priority signal indications (TPSI) may be used to assign right-of-way to public transit vehicles over all other vehicular and pedestrian traffic movements within an intersection. Transit priority signals may be operated exclusively during protected transit movements or concurrently with other non-conflicting vehicular movements.

Transit priority signal indications are specified in HTA Regulation 626 (2), and are mounted directly above the red indications. TPSIs consist of “lunar white” vertical bars on opaque backgrounds. They may have 200 or 300 mm lenses and be mounted on any type of signal heads. TPSIs are generally used at intersections where there are dedicated transit lanes or where their use would improve the efficiency of the transit routes.

Movable Span Bridge Signals

When roadways cross drawbridges, swing bridges, or lift bridges, normal traffic signal heads should be considered in conjunction with control gates or other forms of physical protection.

The needs of large water vessels should be taken into account in the design of bridge signals as large water vessels cannot stop in a short distance and, once activated, the bridge mechanism normally has

to continue to open the bridge. It is good practice to allow a minimum of 15 m between the end of the movable part of the bridge and any barrier protection. This space provides storage for one or two vehicles in an emergency.

Temporary Traffic Control and Portable Lane Control Signals

A temporary traffic control signal is installed for a limited period of time whereas a portable traffic control signal is a temporary traffic control signal that is designed to be transported and reused at different locations. Four different electrical/electronic traffic control devices are currently available for controlling traffic under temporary conditions. The devices and the restrictions on their use are discussed below.

Automated Flagger Assistance Device

The Automated Flagger Assistance Device is not identified in the HTA, but is identified in OTM Book 7¹⁸ as an electro-mechanical device that is remotely controlled and performs the function of a traffic control person in a two-way, one lane traffic operation. The device is considered a supplement to or replacement for a traffic control person, and is not a Traffic Signal or a Portable Lane Control Signal.

The automated flagger assistance device does not use a traditional traffic signal head with a red, amber and green lens. The device uses only a red and an amber lens in conjunction with a control arm to control traffic. Communications between the signals at each end of the one lane traffic operation must be provided in order to prevent conflicting displays. Legal approval for installation is not required as the device is not covered under the HTA, but approval by the road authority is required.

The automated flagger assistance device may only be used to control one lane, two-way operations during construction activities considered under

OTM Book 7¹⁸ as “Very Short Duration Work (VSD)” or “Short Duration Work (SD)” during hours of daylight. Very Short Duration work is defined as work that occupies a fixed location for up to 30 minutes including set up and take down time. Short duration work occupies a fixed location for more than 30 minutes, but less than a 24 hour period. Should the contractor leave the site, the equipment must be removed and two-way flow of traffic resumed. If these devices are to be used during night-time activities, proper illumination must be provided.

Portable Lane Control Signals (PLCS)

Portable Lane Control Signals consist of single “standard” vehicle traffic signal heads, normally mounted on movable poles at a minimum height of 2.75 m from the roadway surface to the bottom of the heads. The use of portable signals is an alternative to continuous flagging by control persons, and is not to be confused with temporary traffic signals.

Portable lane control signals may only be used to control one lane, two-way traffic flow during construction activities, and only for durations considered under OTM Book 7¹⁸ as “Very Short Duration Work” defined as occupying a fixed location for up to 30 minutes including set up and take down time or “Short Duration Work” defined as occupying a fixed location for more than 30 minutes, but less than 24 hour period in duration. The phasing intervals must be a two phase operation only, with the all red clearance interval sufficiently long to clear the previous approach lane of all vehicular traffic. Access points or side streets within the one lane section controlled by the portable lane control signals must be controlled by flag-persons working in conjunction with the equipment. The equipment must be removed and two-way flow of traffic resumed when the contractor leaves the site.

Portable lane control signals must be installed in accordance with the requirements of Regulation 606 of the HTA, which covers the physical and signage requirements for these devices. Driver action is prescribed by HTA Section 146. **Approval of the road authority responsible for the roadway must be obtained prior to use.** Because of the temporary nature of these devices, legal drawings are not required by law.

It is recommended practice that the use of portable lane control signals must only be allowed where the posted speed is 60 km/h or less, and where full illumination exists if the closure continues at night. The signals may not be used at an intersection or pedestrian crossover. It is recommended that portable lane control signals with two signal heads be used, and that the second signal head be located in the standard secondary head location.

Portable Temporary Traffic Signals

Portable temporary traffic signals (PTTS) consist of typical traffic signal heads mounted on movable trailers. The trailers are typically positioned to emulate traffic control signals. **Approval of the road authority responsible for the roadway must be obtained prior to use.**

Portable temporary traffic signals may be used to control one lane, two-way traffic flow during construction activities that are considered under OTM Book 7¹⁸ as “Very Short Duration Work” or “Short Duration Work” during hours of daylight. If these devices are to be used during night-time activities, proper illumination must be provided. The equipment must be removed and two-way flow of traffic resumed when the contractor leaves the site.

Portable temporary traffic signals must be installed in accordance with the requirements of Regulation 606 of the HTA, which covers the physical and signage requirements. Driver action is prescribed by HTA Section 146. A legal approval drawing is

not required for portable temporary traffic control signals.

Portable temporary traffic control signals may also be used to control one lane two-way operations during construction activities considered under OTM Book 7¹⁸ as “Long Duration” work and must be installed to meet the requirements of Regulation 626 and Section 144 of the HTA. If used for “Long Duration” work, a cost comparison is recommended to investigate whether it is more cost effective to use solar powered portable temporary traffic signals rather than regular temporary traffic signals. Portable temporary traffic signals may not be used if a side street or access point is located within the one lane section. (Temporary signals with multiple phasing must then be used.) Legal approval is required prior to use.

The following material and operational requirements apply to portable temporary traffic signals.

Material requirements

- Two trailers (one for each approach to the one lane section being controlled) must make up the system.
- Each trailer must have two operating signal heads.
- The head to be placed over the roadway must be a minimum of 4.5 meters from the roadway surface.
- The heads facing each approach must be separated by a minimum of 3.0 meters.
- The head located over the trailer must be capable of being mounted at 4.5 meters and at 2.75 meters from the roadway surface.
- Highway yellow backboards must be used on each signal head.

- Signal heads must be capable of being reversed on the signal mast arm/boom to allow the trailers to be mounted on the same side of the roadway behind a barrier.
- Signal head displays must meet the signal head visibility requirements for the posted speed of the roadway prior to construction activities:
 - Minimum distance from signal heads to stop bar = 12 m
 - Sight distance requirements as per Table 25
 - Cone of vision requirements from the stop bar and from the stopping site distance
- Each trailer must be capable of operating as a master or slave unit, and the trailers must be interconnected to each other by hardwire, licensed radio, or spread spectrum radio communications.
- Trailer units must be solar powered with battery backup capable of sustaining full operation for at least 14 days without recharging.
- Trailer units must be capable of being operated by generator as a backup power source.
- Upon detection of a conflict, the signal system must enter a fault mode of either flashing red or solid red display on all heads. The determination of solid red or flashing red fault mode must be user selectable. Both modes must be available.
- Upon detection of a fault, the units must have a cellular or satellite paging system to alert the contractor to the fact the signals have entered fault mode.
- The system must be capable of pre-timed signal operations where the green time, the amber clearance, and the all red times can be manually input to the controller.
- The system must be capable of fully actuated operation using a variety of detection devices including loops, microwave, and video detection equipment that will:
 - Place a call for a green indication when red or amber is being displayed.
 - Extend the green indication from a minimum to a maximum green time by a user selectable amount each time a vehicle is detected during the green display (extension time).
 - Rest in red or the last phase served. The user must be able to select this mode through software input on a construction site.

Operational Requirements

- The system must provide conflict monitoring as follows:
 - Master and slave controller watchdog of the controller software
 - Master and slave absence of indication (burnt out lamp)
 - Master and slave conflicting display on the same signal head or heads
 - Master and slave conflicting displays on opposing signal heads
 - The user must be able to manually enter a minimum green time, a maximum green time, and an extension time for actuated operations.
- Portable temporary traffic signals may be used for night-time activities, but only with proper illumination. Proper illumination includes:
- There must be a minimum of one luminaire over each PTTS trailer.
 - Each luminaire must output a minimum of 22,000 lumens.

- Each luminaire must be mounted a minimum of 9 m vertically from the roadway surface.
- The luminaires must be on from dusk until dawn.

If required, the contractor must supply, install, and maintain temporary platforms that rigidly support the traffic signals units in a level plane. The temporary platforms must be of sufficient size to permit maintenance and service of the units. At the end of the contract, the contractor must remove and dispose of the temporary platforms. If portable temporary traffic control signals are used in the winter months, the signals must be configured with environmental controls to ensure they will continue to operate at any temperature.

Temporary Traffic Signals

Temporary traffic signals consist of traffic signal heads positioned on span wires and temporary poles. The signals are used to control traffic during construction activities. Temporary traffic signals should be considered for applications that are defined under OTM Book 7¹⁸ as “Long Duration” work, meaning the work requires a separate work space for longer than 24 hours. Temporary traffic signals have a constant power supply, and closely resemble a normal signal installation. The signals may be used at an intersection or pedestrian crossover.

Temporary traffic signal installations require the approval of the responsible road authority before installation. A legal drawing must be prepared prior to installation as per HTA 144(31). The installations must comply with all regulations pertaining to traffic signals identified in HTA Regulation 626.

Operational and timing requirements for fixed temporary traffic signals are the same as for permanent signals. Full NEMA standard conflict monitoring must be used. Temporary illumination

using a standard design is required for all temporary traffic signal installations.

Tunnel Signals

There are two types of “Tunnel Signals”:

- Signals at the ends of a tunnel that are used to prohibit the entrance of traffic in the case of a mishap within the tunnel
- Lane control signals within the tunnel and on the tunnel approaches used for reversible lanes or for the closure of lanes for maintenance

Bicycle Control Signals, Placement

Bicycles are defined as vehicles in the Highway Traffic Act and therefore are governed by the rules of the road as defined in the act. Under the vast majority of circumstances, standard vehicle displays should be adequate to control bicycle movements through intersections. If bicycle signals are required, standard-sized heads (200/200/200 mm) may be used with appropriate adjacent signing.

Placement of the heads is important to ensure that they are not confused with the signal heads being used for regular motor vehicle traffic. It is recommended that bicycle signal heads be installed in the field of vision of cyclists a minimum of 30 m upstream of the stop bar and mounted in locations far enough from the roadway so as not to interfere with pedestrians or cyclists.

In addition, bicycle heads should be placed at the same height as hand/man displays at the intersection. In situations where the bicycle signal heads must be located over the travelled portion of the roadway, the signals should be placed at a minimum of 4.5 m above the pavement.

It is recommended that special detection be used if bicycle volumes are considered high. Detection may consist of bicycle-specific quadrapole or diagonal quadrapole induction loops and detectors, video detection, special pushbuttons, or other techniques.

5.9 Detection

General

A Vehicle Detector is a device for indicating the presence or passage of a vehicle in a designated area of a roadway. Passage detection is the sensing of a road user in motion within the detection zone. Presence detection is the sensing of a road user in the detection zone, whether stopped or moving.

Vehicle detectors typically provide two types of output: pulse or presence. Pulse detectors produce a short output pulse only when a vehicle enters the detection zone. Presence detectors are able to detect the presence or absence of vehicles within the detection zone. The detector remains “on” until the vehicle is no longer in the zone at which point the output is switched “off”.

Outputs from vehicle detectors are used as inputs to the traffic controller to provide phasing and to determine timing. The detectors may also provide other equipment with the inputs required to calculate volume (vehicles per hour), average or instantaneous speed (kph), occupancy (percent usage of the roadway), density (vehicles per kilometre), and vehicle classifications.

Vehicle detectors/sensors fall into two major categories: Non-intrusive, or above-ground installation; and intrusive, or in-ground installation.

Non-intrusive detectors are typically overhead. They must be rigidly affixed to a pole or other

structure. Detectors placed over the roadway or side fired have a defined detection zone aimed at a specific point. The detectors are subject to weather, lightning and electrical discharges, and vibrations.

Intrusive detectors are typically embedded in the ground or road surface. The detection zones of detectors placed within the roadway surface are defined by the placement of the detector element. The success and longevity of these in-ground detectors depends directly on the condition of the ground / road surface, and the quality of the materials used to construct them. Loop assembly failure caused by electrical leakage to the ground and loss of conductivity can most often be traced to physical damage of the loop assembly either during installation or through pavement movement.

Vehicle detectors are commonly installed at actuated traffic signals, urban and highway permanent vehicle counting stations, and parking lots/garages. In actuated traffic signals, vehicle detection devices are used to indicate the need for a call or extension of green time. The detectors respond to the passage of vehicles over a specific point on the roadway. Vehicle detection devices are also used to indicate that vehicles are present and waiting for signal indications to change, and to indicate that vehicles are in line behind other vehicles waiting for signal indications to change (left turn “setback” loops). At critical intersections, detection zone lengths and gap settings are normally designed to terminate green when headways are greater than two to three seconds.

In areas posted at speeds of less than 80 km/h, there is generally a greater concentration on maximizing intersection efficiency than on dilemma zone protection. The dilemma zone is the area approaching the stop line in which the motorist, on the start of amber will be momentarily undecided as to whether to stop or continue through the intersection, thereby encountering a dilemma. For higher speed locations, use of a combination of

detection and timing techniques to minimize the effects of the dilemma zone is a consideration, even at the expense of some intersection efficiency.

Other forms of detection devices include: pedestrian pushbuttons for detecting the presence of a pedestrian; emergency vehicle detection for detecting a fire truck or ambulance in order to provide right-of-way at an intersection; bus or transit vehicle detection for detecting a high occupancy vehicle in order to provide priority at an intersection; and specialized detection devices for devices such as Accessible Pedestrian Signals at an intersection.

Types of Vehicle Detectors

As there are many brands and types of vehicle detectors, the detectors available should satisfy most applications. A summary of the common types follows.

Microwave

Microwave detectors are mounted above the ground and project a cone shaped detection area. When a vehicle approaches, the vehicle reflects some of the microwave energy back to the detector, providing a momentary contact closure (pulse) to indicate that a vehicle has been detected.

Infrared

There are two types of infrared detectors:

- **Passive** – Passive infrared detectors detect the presence of vehicles by comparing the infrared energy naturally occurring in the detection zone with the change in energy caused by a vehicle
- **Active** – Active infrared detectors detect the presence of vehicles by emitting a low energy beam at the roadway and measuring the reflected signal's return to the device

Acoustic

Acoustic detectors use pulses of ultrasonic sound which are directed at the roadway. The total travel time of the reflected sound is measured and compared to the previous measurement. A shorter time measurement indicates that a vehicle is present.

Video

Video detection is accomplished through an image processor. The detector consists of a microprocessor-based CPU, and software programmed to analyze video images. The user places virtual "detectors" on the video image displayed on a monitor. Each detection zone emulates an inductive loop vehicle sensor.

Pressure Detectors

Pressure detectors are activated by the weight of a vehicle on a pneumatic tube placed across the roadway or on a metal frame and plates installed in the roadway. The pneumatic tube version is often used with count station equipment temporarily placed by a roadway for short period traffic data collection (typically less than a week). The metal frame and plate version is reliable, but its use is now very limited due to high installation costs and the resulting adverse pavement conditions.

Magnetic Detectors

There are four types of magnetic detectors:

- Standard
- Directional (no longer available)
- Magnetometer
- Self powered vehicle detector (SPVD)

The standard magnetic detector cannot sense vehicles moving at less than 8 km/h and therefore cannot provide presence detection.

Loop Detectors

The current practice of many jurisdictions is to use loop detectors. Loop detectors consist of an amplifier located in the controller cabinet and coiled wires in the pavement. The coiled wires create an electro-magnetic field that changes when a vehicle is in the loop area. Loop detectors are the most widely used type of vehicle detection because of the flexibility of their design. Loop detectors can be used to sense vehicle presence, passage, lane occupancy, speed, and volume.

Other types of detection are available and are continually being developed. For the purposes of this section, detector design will be described using loops. If alternative forms of detectors are used, the road authority should ensure that the operational features are similar to those of loops.

The location and correct positioning of detection devices is of the utmost importance if actuated control is to be effective. Good design requires that objects affecting detector performance be taken into account. Objects that may affect detector performance include parked vehicles, manhole covers, transit stops, service stations or other facilities with busy entrances, etc.

System loops may be square or diamond shaped loops. The loops are installed in each lane. For a central computer system, loops are placed only on strategic arterials and in either inbound (towards the central business district) or outbound lanes. The traffic volumes, speeds and volume/densities on only a few sets of loops may then be used in software algorithms to select timing and phasing plans. For systems such as the Split Cycle Offset Optimization Technique (SCOOT), dual sets of system loops are placed in each lane well in

advance of each intersection so that the optimal cycle length and offset timing may be calculated and transmitted to the next intersection.

Presence Loop Detectors

Presence loops are used to: detect the presence, or continuing occupancy, of vehicles; provide calls to the controllers; or extend green times for vehicles. The loops can be installed at or near the stop lines at intersection approaches, or as “setback” loops in turning lanes to detect whether there are two or more vehicles waiting to turn.

Presence loops may: be rectangular or irregular in shape; be lane selective (installed as separate loops in each lane), or all inclusive (installed as one loop across several lanes); and they may have a user settable time delay (1 to 15 seconds) feature that allows vehicles to stop, pause, and continue without registering a call (as in right-turn lanes).

The recommended placement of presence loops requires maximum setbacks of 4.5 m from the intersecting through edge of pavement, and a coverage area behind the stop lines of 12 m in length for posted speeds of 80 km/h and above, and 5.0 m minimum otherwise. These configurations are shown in Figure 42.

Long Distance Loop Detection

Long distance detection provides an extra level of safety for motorists travelling at a high speed towards a signalized intersection by providing dilemma zone protection. The system uses inductive loops located upstream of the intersection to sense approaching vehicles.

In the MUTCDC:

“The dilemma [zone] is the location at which the driver; upon seeing the signal indication change from green to amber, must decide either to bring

the vehicle to a safe stop before entering the intersection, or to enter and clear the intersection prior to the start of the conflicting green phase.”

When a vehicle passes over the loops, the signal controller extends the green time to allow the vehicle to pass through the dilemma zone before the on-set of the amber signal indication.

Long distance passage loops are normally used at intersections to provide actuation of signal phases or extended green times for vehicles passing through the dilemma zone. When used for actuation, the loops are sometimes called “trip loops”. When used to extend green times, the loops are sometimes called “extension loops”.

Long distance detection generally consists of a single “simple loop” centred in each through lane of the mainline approach that is located at the upstream edge of the dilemma zone. With actuated signal timing, both approaches receive a minimum green interval, a vehicle extension period, and a maximum green interval. The vehicle extension period is intended to carry a vehicle from the outside edge of the dilemma zone to a point representing at least a one second distance from the stop bar (past the inside edge of dilemma zone).

Long distance detection is most effective where signals routinely “gap-out” just when vehicles are approaching the signal. A maximum green time should be established based on prevailing traffic conditions (on all approaches). Time of Day Functions that alter the maximum green time if traffic demands change through the day can be considered.

Long distance detection should be implemented at intersections on roadways that meet all of the following criteria:

- operating speed is greater than 60 km/h
- traffic signals are fully actuated

- the intersection is isolated, non-interconnected, or interconnected with off peak free modes operation

The key elements for successful operation of long distance detection are the placement of the long distance loop on the mainline approach, and the vehicle extension time provided for each loop activation. If the loop is placed too close to the intersection, vehicles may enter the dilemma zone before activating the loop. If the loop is placed too far from the intersection, providing short vehicle extension periods may result in motorists being in the dilemma zone at the on-set of amber, but providing vehicle extension periods that are too long can increase vehicular delay and the probability of max-out during high volume situations.

As a recommended practice, long distance loops should be used as extension loops to extend green time on the main road for roadways of posted speed of 80 km/h or more, but the loops may also be beneficial to signal operations on roadways with lower posted speeds. The loops are normally installed per lane, and are of 1.8 x 1.8 m square configuration or the equivalent size diamond shaped loops, as shown in Figure 43. The distance from the stop line to the extension loops is based on the time of entry of the dilemma zone, as shown in Table 27.

The design of loops details (simple, duplex (quadrapole TM), powerhead, preformed, etc.,) and alternative detection devices is beyond the scope of this manual. Further details are available in the Ministry’s Electrical Engineering Manual³.

To promote efficient and safe intersection operation, the loop detector placement and vehicle extension timing parameters summarized in Table 28 should be used.

The distances for loop detector placement shown in Table 28 are typically taken from the approach stop bar, and represent the outside edge of

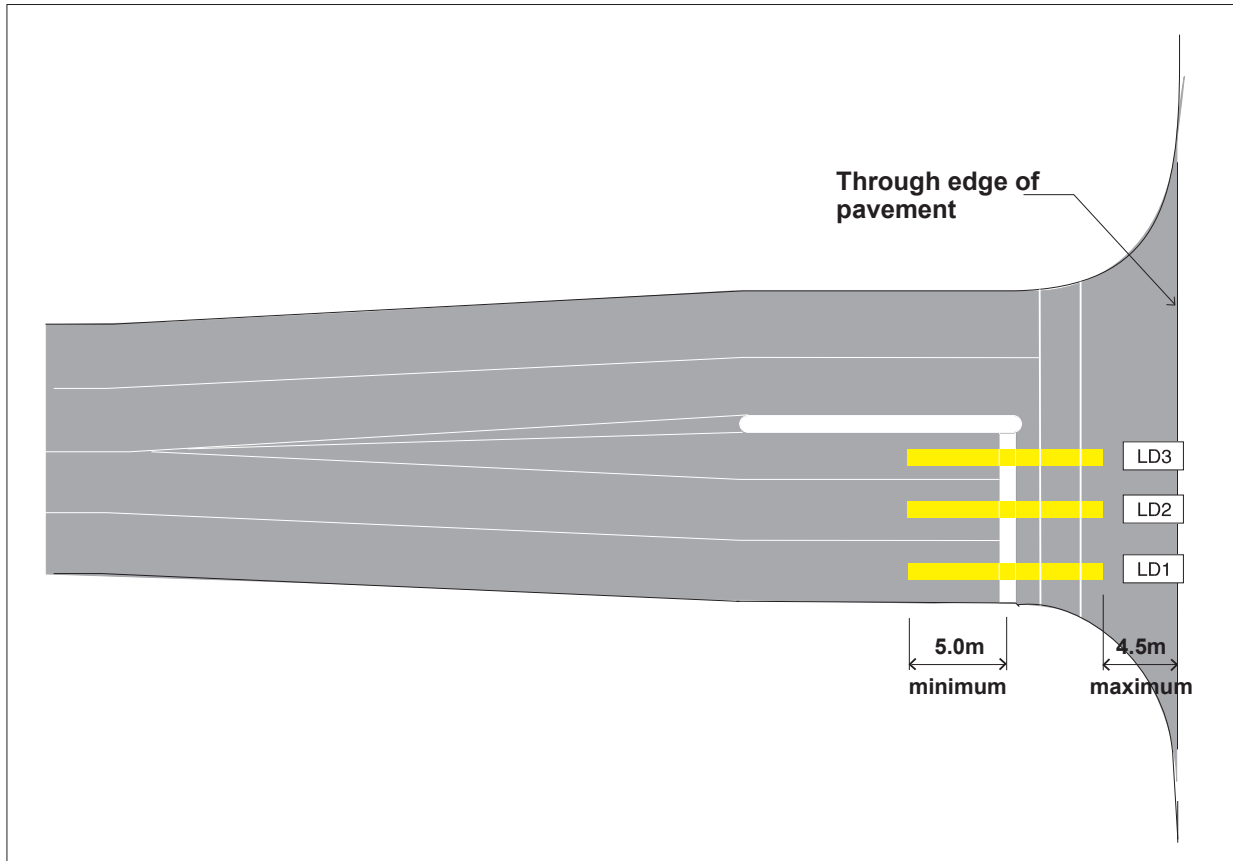

Figure 42 – Presence Loops

the dilemma zone for operating speeds up to 90 km/h. For operating speeds greater than 95 km/h, the loop detector location is based on the ITE stopping distance formula and for this speed range, the formula should be used with an average deceleration rate of 3 m/s² to calculate braking distance as below:

$$d = v^2 / [254(\frac{a}{9.81} \pm \frac{G}{100})]$$

Where:

d = stopping distance (m)

v = velocity (km/h)

a = deceleration rate (m/s/s), typically 3.0 m/s/s for speeds over 95 km/h

G = grade in %, positive for uphill, negative for downhill

Where the operating speed (85th percentile speed) of the roadway is not known, a value equal to 10 km/h above the posted speed limit can be used. It is recommended that a spot speed study be undertaken to determine the actual operating speed of the roadway before installing long distance detection. Figure 44 shows the recommended installation for long distance detection.

Double Long Distance Detection

Double Long Distance Detection is best used where high speed vehicles (vehicles travelling above the operating speed of the roadway) are creating a safety concern. Double long distance detection uses information collected from two loops to infer whether a vehicle is travelling above or below a

predetermined threshold speed (typically set at 10 km/h above the operating speed). If a vehicle is travelling at or above the threshold speed between the two loops, a green extension is provided to allow the vehicle to pass through the dilemma zone before the onset of amber. However, if a vehicle is travelling below the threshold speed between the two loops, the signal will gap-out and the amber will be displayed. Double long distance detection can accommodate a greater range of vehicle speeds than long distance detection while maintaining efficient signal operations.

Double long distance detection consists of two sets of "simple loops" centred in each lane of the mainline approach. The loop closest to the intersection (Loop 2) is located as per Table 29 for the operating speed of the roadway. The loop

furthest from the intersection (Loop 1) is located at a fixed distance of 50 m upstream of Loop 2.

In actuated signal timing operation, the mainline approaches receive a minimum green interval, vehicle extensions from Loop 1 and Loop 2, and a maximum green interval. Loop 1 applies an extension interval that is intended to carry a vehicle travelling at or above the threshold speed from Loop 1 to Loop 2. Loop 2 applies the extension interval plus a carryover interval to carry a vehicle from the outside edge of the dilemma zone to a point representing at least one second in distance from the stop bar (past the inside edge of the dilemma zone).

Double long distance detection is intended to supplement long distance detection, and is

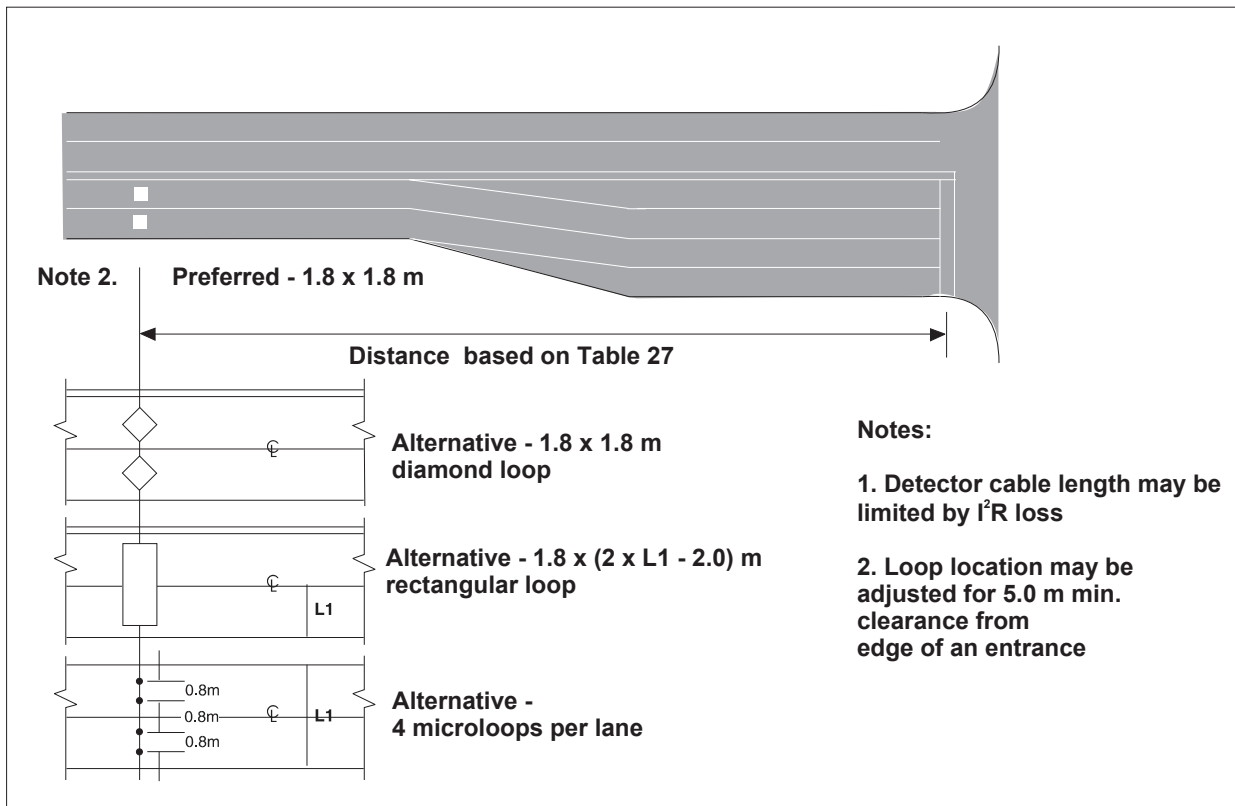

Figure 43 – Extension Loops

Table 27 – Distance from Stop Line for Long Distance Loops

<i>Operating Speed (85th percentile)</i>	<i>Distance from Stop Line (m) (based on edge of dilemma zone)</i>	<i>Distance from Stop Line (m) (based on five second line)</i>
60	70	85
70	90	110
80	110	115
90	125	125
100	140	140

Table 28 – Long Distance Detection Operating Parameters

OPERATING SPEED (km/h)	LOOP PLACEMENT (DL1) (metres from stop bar)	MINIMUM VEHICLE EXTENSION PERIOD (seconds)
60	70	3.2
65	80	3.4
70	90	3.6
75	100	3.8
80	115	4.0
85	120	4.0
90	125	4.0
95	165	5.3
100	175	5.3
105	190	5.5
110	205	5.7
115	228	6.1
120	244	6.3

generally implemented at intersections where long distance detection is already in place. Before considering double long distance detection, the 85th percentile speed of the roadway should be determined. The existing long distance detection system should be reviewed to confirm that the detector placement and the vehicle extension period conform to the recommended implementation as outlined in Table 28.

It is recommended that double long distance detection be implemented at intersections on roadways that meet the following criteria:

- The grade approaching an intersection requires more than the normal braking effort (3% or greater).
- Commercial vehicles account for considerable percentage of traffic (e.g., 20 – 25% or above).
- There is evidence that commercial vehicles are having difficulty stopping.
- Operating speed is equal to or greater than 90 km/h.
- Operating speeds exceed the posted speed limit by 20 km/h or more (threshold speed).
- The approach is operating at a level of service C or better.

- The intersection is isolated, rural, or non-interconnected.

Double Long Distance Detection should not be used on approaches that use True Active Advance Warning Signs.

To ensure that the intersection operates in a safe and efficient manner, the intersection should be studied during the peak periods before and after the installation of double long distance detection to determine “max-out” rates. If the intersection is maxing-out for 25% or more of the cycles during the peak periods before or after the installation of the device, double long distance detection should be turned off during the max-out periods (where signal controller capabilities permit). Turning the double long distance detector (Loop 1) off will result in a higher gap-out (rather than max-out) rate for the intersection during these periods.

The key elements for successful operation of double long distance detection are the placement of the loops on the mainline approach, and the vehicle extension intervals provided for each loop activation. If Loop 2 is placed too close to the intersection, or too far from it, vehicles may enter the dilemma zone before activating the loop, or they may be in the dilemma zone when the vehicle extension period has terminated. If Loop 1 is not

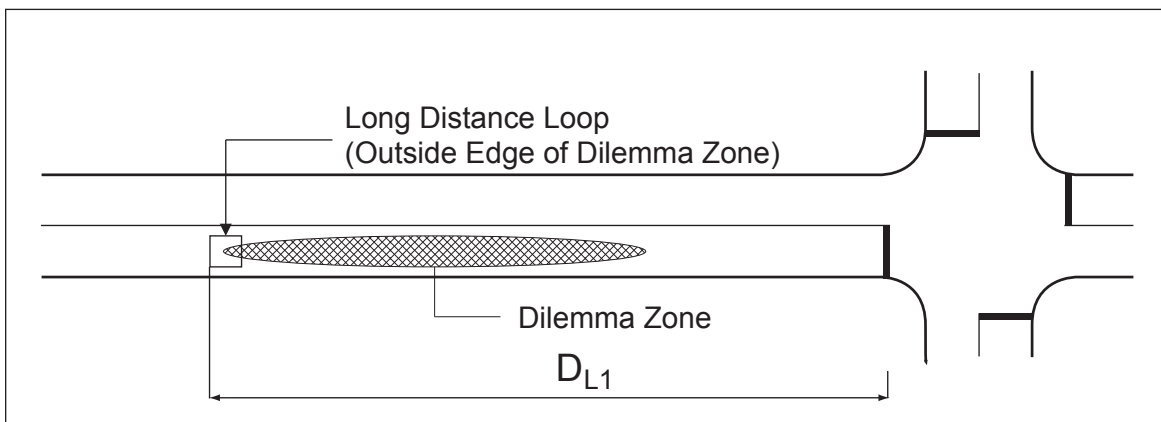

Figure 44 – Long Distance Detection – Recommended Installation

correctly placed, the signal controller may falsely infer that a vehicle is travelling above (too close) or below (too far) the predetermined threshold speed. In addition, providing excessive vehicle extension periods for both loops wastes valuable cycle time, and increases the probability of max-out.

To promote efficient and safe intersection operation, the loop placement and associated vehicle extension intervals summarized in Table 29 are recommended. Figure 45 shows the recommended installation for double long distance detection.

The predetermined threshold speed is generally recognized as 10 km/h above the operating speed, where the operating speed is either the 85th percentile speed or 10km/h above the posted speed.

Where existing double long distance detection is in place and the loop placement differs from the recommendations outlined above, the following formula must be used to determine the proper vehicle extension interval:

$$I = D/V_T$$

Where: I = vehicle extension interval (seconds)
 D = distance between loops 1 and 2
 V_T = threshold speed (m/s)

5.10 Layout Design

General

The general requirements of Subsection 5.3 should be closely followed when laying out primary and secondary head and pole locations. This section (Subsection 5.10) uses several examples of intersections to illustrate the various requirements.

Crosswalks and Sidewalks

General

This section on crosswalks and sidewalks gives an overview of the design procedures required to produce the signal and crosswalk/sidewalk designs related to the overall traffic signal design. The material in this section should be treated as the first step in a detailed design.

Design of Crosswalks and Sidewalks

1. Coordinating Crosswalk Locations

Inappropriate designs of crosswalks and sidewalks can significantly hinder the design of a set of traffic control signals. It is the responsibility of the signal designer to ensure that any changes to the preliminary design are compensated for by appropriate changes to the design of crosswalks and sidewalks.

Crosswalk locations are critical to pedestrian signal and pushbutton locations. For new roadway construction or reconstruction, the design of the crosswalks must be coordinated between the road designers (sidewalks and dropped curbs are affected) and the traffic signal designers (pedestrian signal facilities are affected).

Sidewalk locations that are designed at the property line and leave a large boulevard between the back of the curb and the sidewalk are unacceptable at signalized intersections because pedestrians must have access to pushbuttons and must cross properly at crosswalks. The sidewalk design should be locally adjusted to meet these conditions, as shown in Figure 46.

The layout design of pedestrian signals and pushbuttons must be integrated with the other signal elements. Some basic guidelines for the layout of crosswalks and sidewalks are provided below.

Table 29 – Double Long Distance Detection Operating Parameters

OPERATING SPEED	PLACEMENT OF LOOP (metres from stop bar) (Based on operating speed)		MINIMUM VEHICLE EXTENSION PERIOD (seconds)	
	LOOP 1 DL 1	LOOP 2 DL 2	LOOP 1 (ext) (threshold speed)	LOOP 2 (ext + carry) (operating speed)
80	165	115	2.3	4.2
85	170	120	2.1	4.1
90	175	125	2.0	4.0
95	215	165	1.9	5.3
100	225	175	1.8	5.3
105	240	190	1.7	5.5
110	255	205	1.6	5.7
115	278	228	1.6	6.1
120	294	244	1.5	6.3

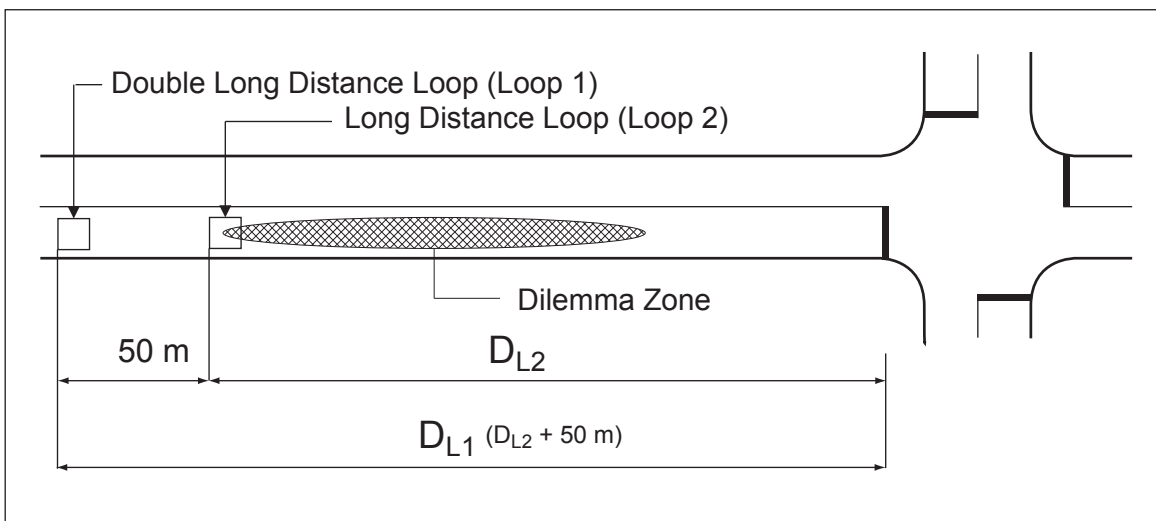

Figure 45 – Double Long Distance Detection – Recommended Installation

2. Crosswalks

The design of pedestrian crosswalks is not a fixed science and is subject to opinions and preferences. The examples given here are representative of systems in use.

Figure 47 shows a typical intersection on which one side is standard and the other side is modified. The crosswalks are laid out according to the following guidelines:

- The minimum crosswalk width is 2.5 m. The desirable crosswalk width is 3.0 m. The width may be increased to match wider sidewalks in downtown areas or to allow greater two-way pedestrian volumes.
- The outer edge of the crosswalk is normally 1.0 m from the edge of the stop line. If necessary, the stop line location can vary from the standard location (which starts at the end of the island).
- The inner edge of the crosswalk should be a minimum of 0.5 m from the through edge of the pavement of the parallel roadway for roadways posted under 80 km/h, and 1.0 to 1.5 m for roadways posted at 80 km/h and above.
- It is preferable to have each crosswalk reach the far curb without intersecting with the other crosswalk across the other roadway. This layout directs pedestrians to the far sidewalk to await the other pedestrian signal instead of waiting near the curb in the pavement area.
- Where the geometry is difficult and the crosswalks tend to intersect in the turning flare, it is better to have the inner edges intersect at the curb than to carry each set of lines through each other.
- Crosswalks should line up with proposed sidewalks or dropped curbs.
- Where existing geometry is used, the edges of crosswalks should line up with existing poles to improve pedestrian signal head visibility and pushbutton accessibility.
- Crosswalks should not cross over the centre median island on roadways with posted speeds of 80 km/h and more, and should not cross over any median not equipped with wheelchair ramps or at-grade depressions.
- Consideration should be given to snow-covered roadways where crosswalk lines may not be visible. Wherever possible, the crosswalk lines should be within the most direct route from sidewalk to sidewalk.
- Crosswalks should be as short as possible without compromising other design factors.

3. Sidewalks

The sidewalk and dropped curb designs should be coordinated with the road designer after crosswalks and all other equipment have been designed. The following guidelines should be considered:

- The sidewalk approaches to the curb should fall within the edges of the crosswalks, not on the stop line, etc.
- Where possible, the pole footings (at least for poles with pushbuttons) should be flush with sidewalks or hard surfaces (sidewalk extension, asphalt, etc.).
- Where concrete or asphalt concrete sidewalks are not available, a finished surface such as asphalt should be considered for placement between the pedestrian pushbutton and other hard surfaces.

4. Integrated Design

Care in the placement of the crosswalk markings during the design can improve the appearance and operation of the intersection. The dropped curbs and dropped sidewalk ramps should be shown

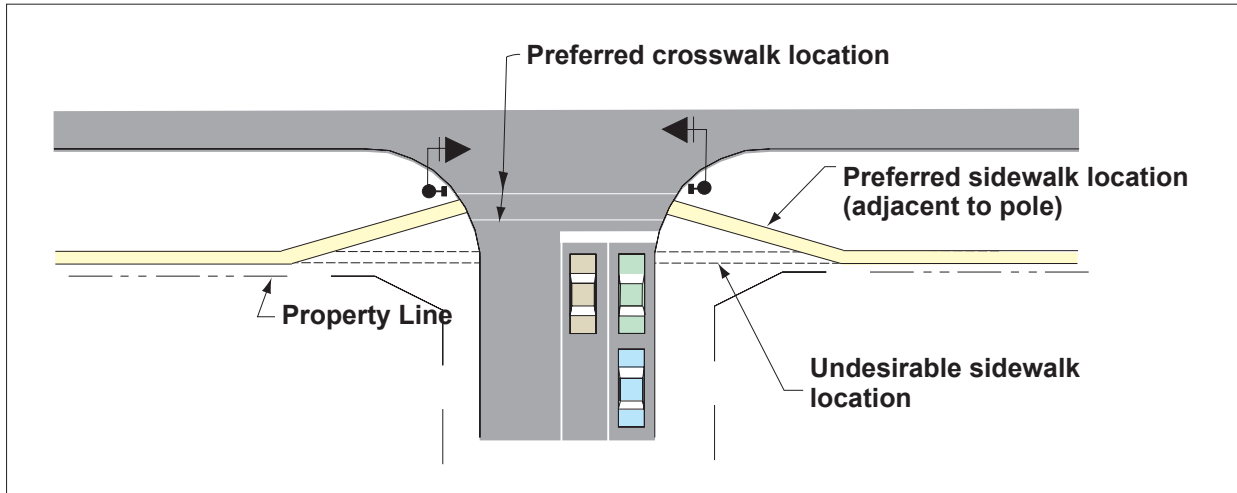

Figure 46 – Crosswalk and Sidewalk Locations

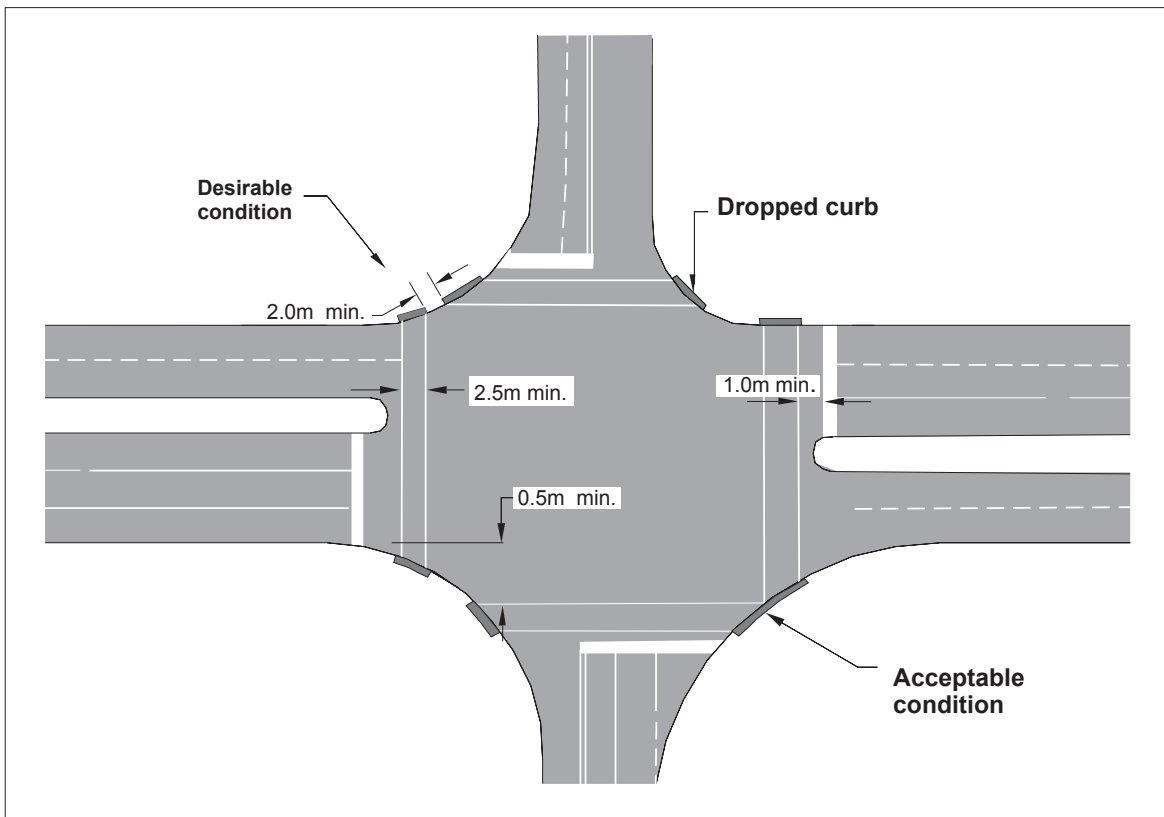

Figure 47 – Crosswalk Design

on the roadway plans, and must match up with the final pavement markings. Where sections of dropped curbs are separate but close together, the crosswalks should be separated sufficiently to allow a 2.0 m (desirable top-to-top distance) length of raised curb, as shown in Figure 47, or should be brought together with the inner lines meeting to eliminate the curb “bump.” It should be noted that the “bump” provides guidance for visually impaired pedestrians, and deters motorists from mounting the curb.

The final markings must be coordinated with the road designers to suit pedestrian pushbutton and pedestrian head locations. It is sometimes necessary to revise median island designs to suit desirable crosswalk schemes while maintaining truck turning radii.

5. Large Radii

Very large truck turning radii may leave a large area of flared pavement. This flared pavement may increase pedestrian walk time. The possibilities of installing a channelization island, as shown in Figure 48, should be investigated and discussed with the road designers.

A channelizing island removes turning traffic from the intersection, offers a pedestrian refuge area and provides a place to install a traffic signal pole. There are safety concerns associated with designing islands. Under the current legislation, it is difficult at best to provide for clear pedestrian right-of-way and vehicle-pedestrian conflicts can occur. Also, channelized right turns reduce pedestrian mobility. For channelized right turn lanes, crosswalk markings should not be applied on the ramp.

For posted speeds of 80 km/hour and greater, the minimum island size should be restricted to 10 m on any one side, and should be large enough to obtain a minimum of 3.0 m offset to the pole from any side. For posted speeds of less than 80 km/h, the minimum island size should be restricted to 3.7 m on any one side. The island should be large

enough to obtain a minimum of 1.5 m offset to the pole from any side (a 3.0 m offset is preferred if attainable). From an operational perspective, for roadways posted at 80 km/h and greater, a full right-turn channelized lane with adequate storage to remove all right-turning vehicles from the signal operation is preferred. A full acceleration lane for proper and safe merging on the crossing road is also preferred.

5.11 Utilities

General

The designer must capture the temporary and final location of utilities that will be on site during traffic signal construction. The final locations may include existing utility locations (where relocations are not required for roadway purposes), relocated utilities, or combinations of existing and relocated utilities (as is normally the case if roadway construction is involved). The designer should not assume that utilities marked up from a field visit to the site are to remain in place throughout construction. As most intersection reconstruction projects widen the pavement, most pole lines require relocation, and will not be in the same location at the time of construction.

The road authority’s utilities coordinator is responsible for arranging for the location, financing, and timing of utility relocations. The basic co-ordination is normally carried out shortly after grading cross-sections are available. This practice sometimes leaves little time for the designer to co-ordinate the traffic signal work.

The designer must review the final locations of all utilities, with special emphasis on overhead high voltage lines. In some cases, it may be necessary to re-open negotiations and arrange for mutually acceptable pole locations or power line heights. Many utilities have a right to be present on the right-of-way under the Public Utilities Act.

(This provision applies to hydro, telephone, sewerage and watermain works, and does not normally apply to natural gas or cable television.) Other utilities owned by the road authority, for example, fibre optic cable, should also be checked. The utilities must co-operate to find a location satisfactory to the roadway authority. In most situations, locations that are satisfactory to both the utility and the road authority can be found. In many cases, the signal design must be adapted from the standard design to a compromise design.

Guidelines

The designer should be aware that some underground utility plans are not reliable. Many utility plans have not been updated to “As Constructed” status. Utility stake-outs are

usually only reliable to within ± 1 m. With these approximations in mind, the designer has two options:

- Arrange for spot excavations. The survey of the exposed utility can be plotted on a plan. This approach is normally required for large and important utilities such as underground high voltage cables, fibre optic cables, and high pressure gas lines. Where the exact location of the utilities is known, signal equipment may be designed for 0.5 m clearance.
- Allow for 1.0 m minimum clearance between the utilities (including infrastructure such as storm sewers, sanitary sewers, watermains, and culverts) and the traffic signal equipment. Note that “clearance” is to the side of the equipment, not the centreline.

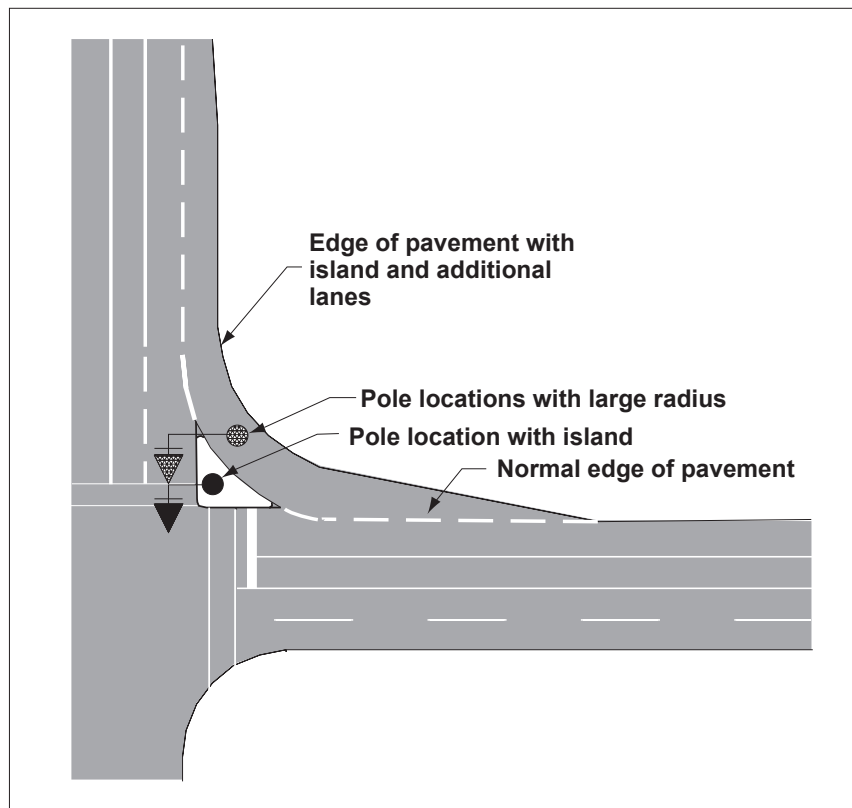

Figure 48 – Use of Right-Turn Island

High voltage lines (over 750 V) require a minimum clearance of 3.0 m for local distribution lines up to 44 kV, and larger clearances for higher voltages as defined in the requirements of CSA Standard C22.3 No. 1 M (see www.ccohs.ca/legislation/csa.html). Note that these regulations are enforced in law under the Occupational Health and Safety Act. For transmission lines, Hydro One must be notified. Hydro authorities can normally be employed to protect signal workers and equipment from high voltage lines during installation of traffic signals if it is necessary to work within the clearance zone.

All electrical work on a public right-of-way in the Province of Ontario is subject to inspection and approval by the Electrical Safety Authority (ESA) before energizing the electrical equipment. The Traffic Signal Practitioner is advised to visit the ESA website to review the ESA requirements and standards (see www.esasafe.com).

Without exception, the designer should inquire as to the voltage present and should be prepared to design the traffic signals to meet or exceed the clearance requirements, or have the electrical utility carry out suitable relocations.

The following guidelines are suggested:

- Where possible, a plan layout should be developed by allowing a minimum of 5.0 m between horizontal centres of electrical pole lines and traffic signal poles. Where distribution crossarm construction exists or is planned, the clearance should be increased beyond that used for the normal standoff type insulators.
- As much clearance as possible is definitely desirable. Good practice suggests that traffic signal poles should be at least 5.0 m from overhead lines (as measured horizontally), or the power lines should be relocated so that the signal equipment can be mounted on the utility pole. In difficult situations, it may be possible to negotiate for an increase in the utility pole and line heights to clear the signal

equipment, but in practice this approach is somewhat idealistic and difficult to achieve within congested right-of-ways.

- Where lighting is required, the designer should use the electrical utility poles if adequate luminaire mounting height can be negotiated.

With the exception of the electrical neutral, overhead low voltage lines are insulated. A minimum clearance of 300 mm is required to prevent rubbing of the insulation. In negotiating with the electrical utility, it is desirable to try to have the neutral and any low voltage cables raised locally from the normal 8.0 m above grade to 9.5 m above grade (one pole length increment of 1.5 m) so that the neutral and low voltage cable locations are well above the tops of 7.5 m signal poles, and so that a lighting bracket attachment height of 10.3 m can be installed.

There is no requirement to maintain a clearance of greater than 150 mm from telephone or cable television lines. Efforts must, however, be made to arrange for these utilities to be raised if the cables will visually obstruct the traffic signal heads.

5.12 Layout Practice

General

In the drawings to follow (Figures 49-59), the "Standard" layout indicated is for an approach with Highway type heads and possibly advanced green arrow heads.

Guidelines by Example

The following examples are provided:

Figure 49 "T" Intersection Approach

Figure 50 Approach Without Median Island (Standard or Advanced Green)

Figure 51 Approach Without Median Island (Fully Protected Left Turns)

Figure 52 Approach With Median Island (Standard, Advanced Green or Simultaneous Protected/ Permissive Lefts)

Figure 53 Approach With Median Island (Fully Protected Left Turns)

Figure 54 Approach With Wide Median (Fully Protected Left Turns)

Figure 55 Approach With Double Lane Left Turn Lane (Fully Protected Left Turns)

Figure 56 Ramp Terminal Opposite Free-flow Ramp

Figure 57 Short Offset Intersection

Figure 58 Long Offset Intersection

Figure 59 Pedestrian Signal Poles

“T” Intersection Approach

Figure 49 shows a typical “T” intersection with two-way traffic on the side road. Note the following:

- Standard Highway heads may be used.
- For safety reasons, the primary and secondary poles should be located clear of the edge of the projected through lane. The desirable setback is 3.0 m clearance for roadways posted at 80 km/h and over, and 1.5 m minimum for roadways posted at under 80 km/h.
- Double left or right turn lanes should not move simultaneously with conflicting pedestrian crossings.

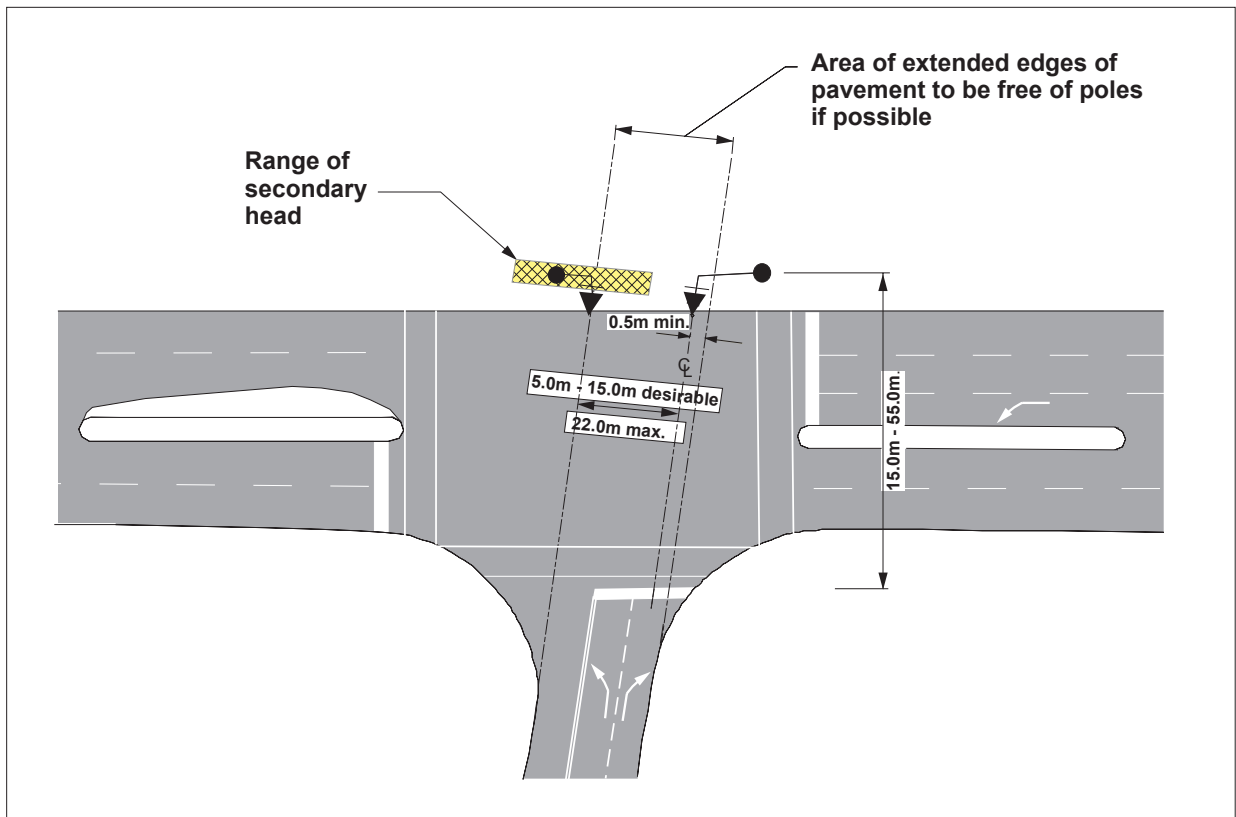

Figure 49 – “T” Intersection Approach

- If mast arm lengths allow, the poles should be within 3.0 m of the crosswalk to enable pushbutton and pedestrian head installation on the same poles.

Approach without Median Island (Standard or Advanced Green)

Figure 50 shows a typical simple approach without a median island and with normal or advanced green indications. Note the following:

- There is no median pole and therefore the primary head should be at or close to the centre of the lane.

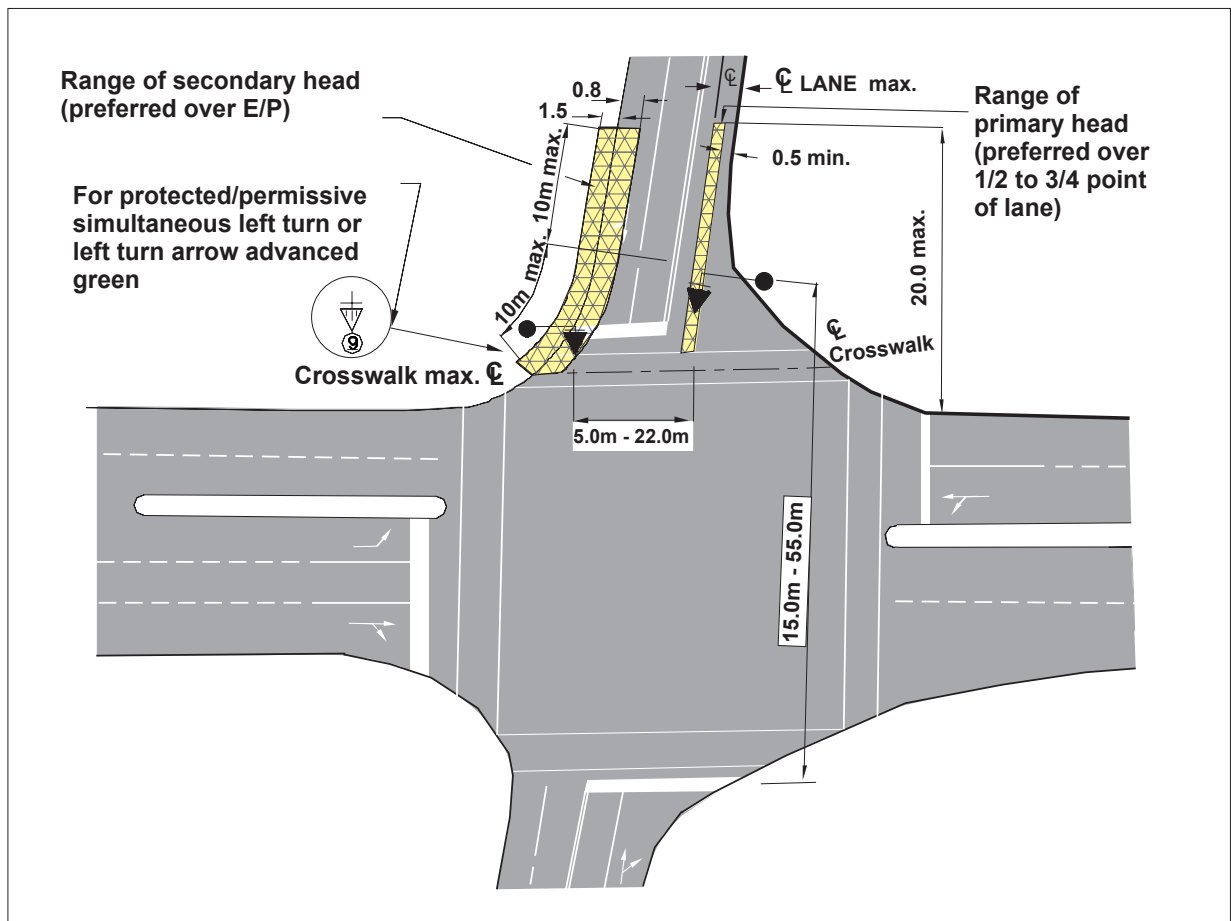

Figure 50 – Layout at Approach Without Median Island

Approach without Median Island (Fully Protected Left Turns)

Figure 51 shows a single lane left-turn approach without a median island and with fully protected left-turn indications. Note the following:

- This application uses an aerial installation of the left-turn (type 2) heads because of the requirements for placing the primary left-turn head within the projected left-turn lane.
- This application is normally used only as an interim measure until the intersection can be reconstructed with islands.

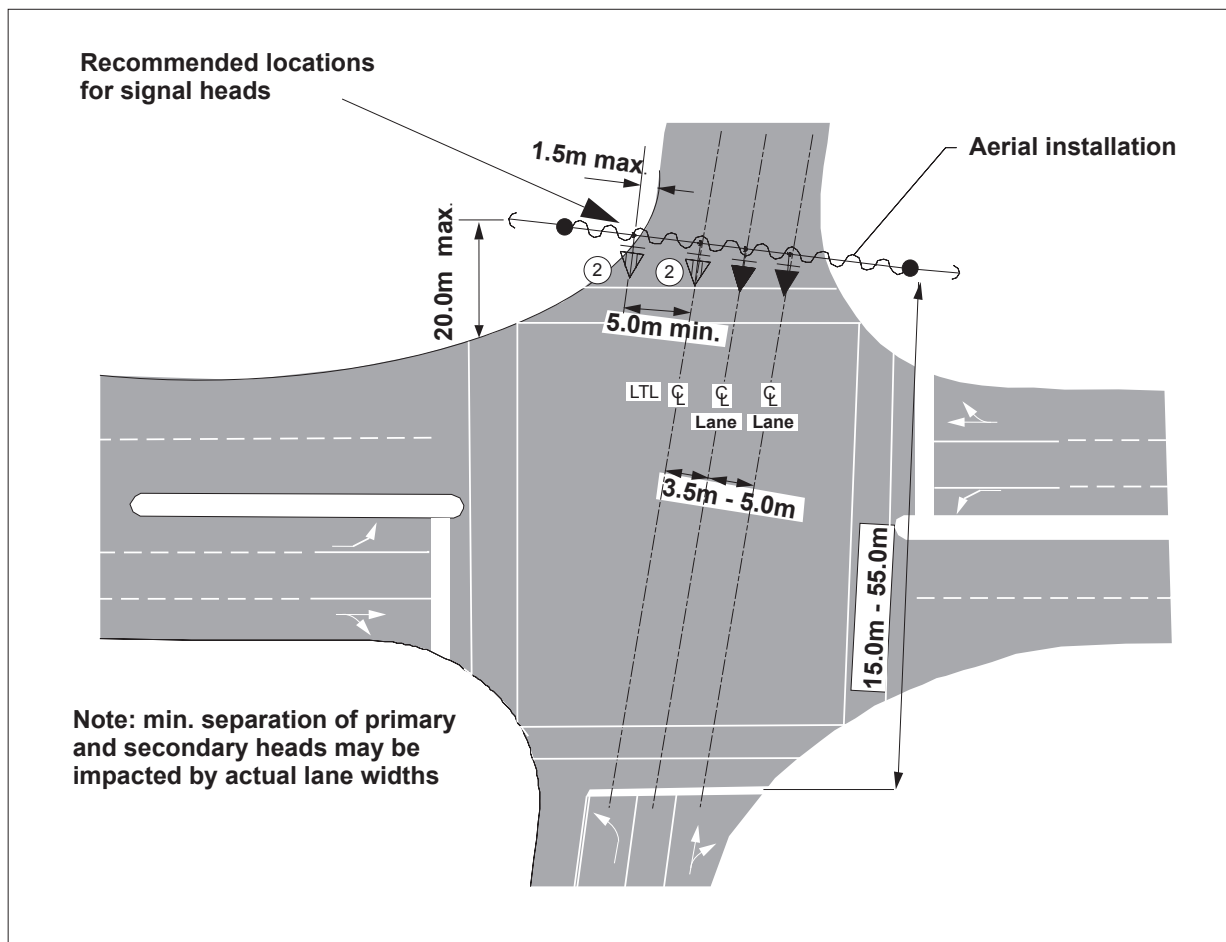

Figure 51 – Approach with Fully Protected Left Turn Heads and Without Median Island

Approach with Median Island (Standard, Advanced Green or Simultaneous Protected/Permissive Lefts)

Figure 52 shows two approaches. One approach has typical Highway heads. The opposing approach has a typical Highway head for the primary head, and a protected/permissive head using the type 8, 8A, 9 or 9A signal head in the median. Note the following:

- As recommended practice, the median (secondary) head is roughly over the edge of the through pavement. Standard mast arm lengths “S” depend on the narrow median width “W”:
- The combination of heads used does not allow for a protected north to west left turn. Simultaneous protected/permissive left turns are possible only where both median indications are type 8, 8A, 9 or 9A.

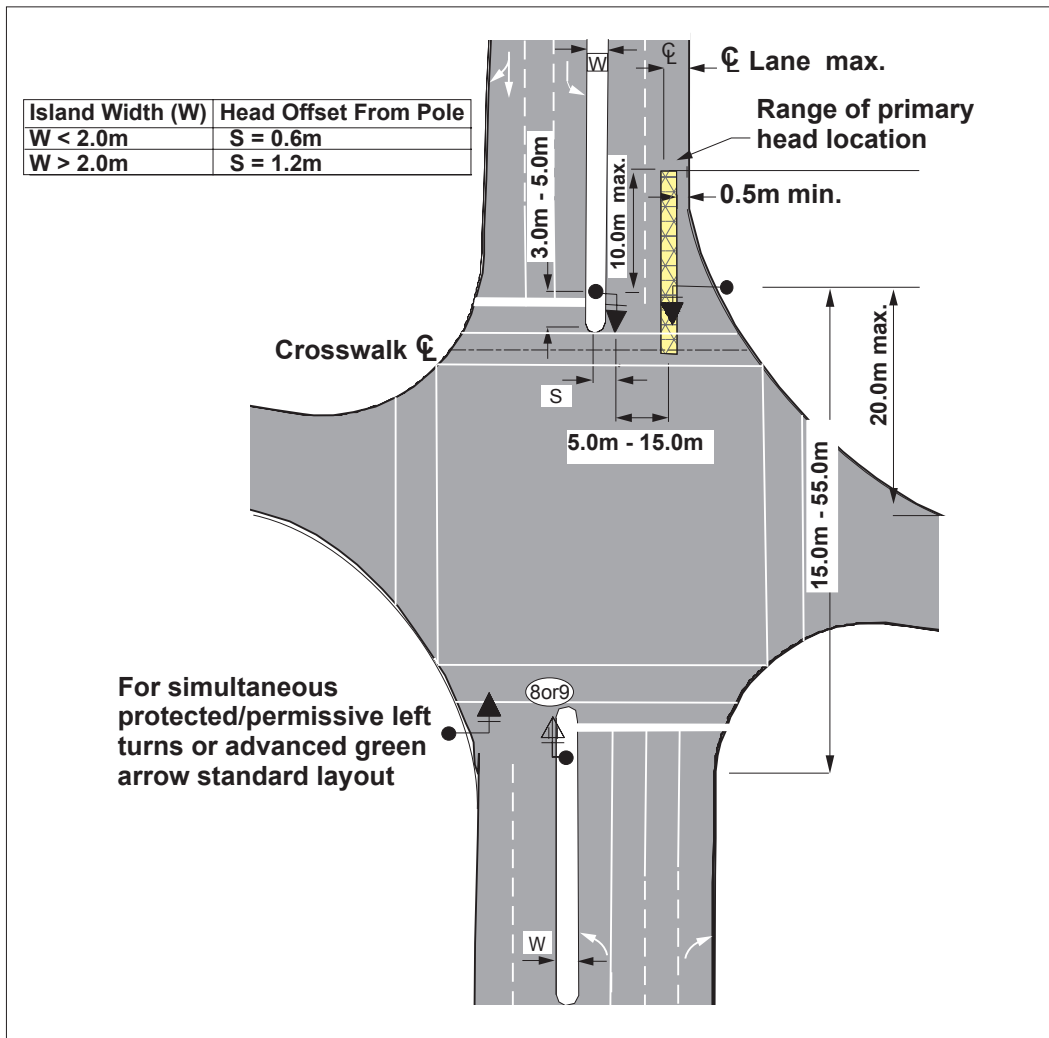

Figure 52 – Standard or Protected Permissive Layout

Approach with Median Island (Fully Protected Left Turns)

Figure 53 shows a single lane left-turn approach with a median island and fully protected left turn indications. Note the following:

- The left-turn primary head is to be located only within the projected edges of the left-turn lane (LTL).
- The practical mast arm length “S” of the primary left-turn head depends on the narrow median width “W” and is normally 1.2 m.
- The primary left-turn head must be separated from the secondary through movement head by at least 2.4 m. The secondary through movement head must be separated from the primary through movement head by 5.0 m minimum and 15.0 m maximum.

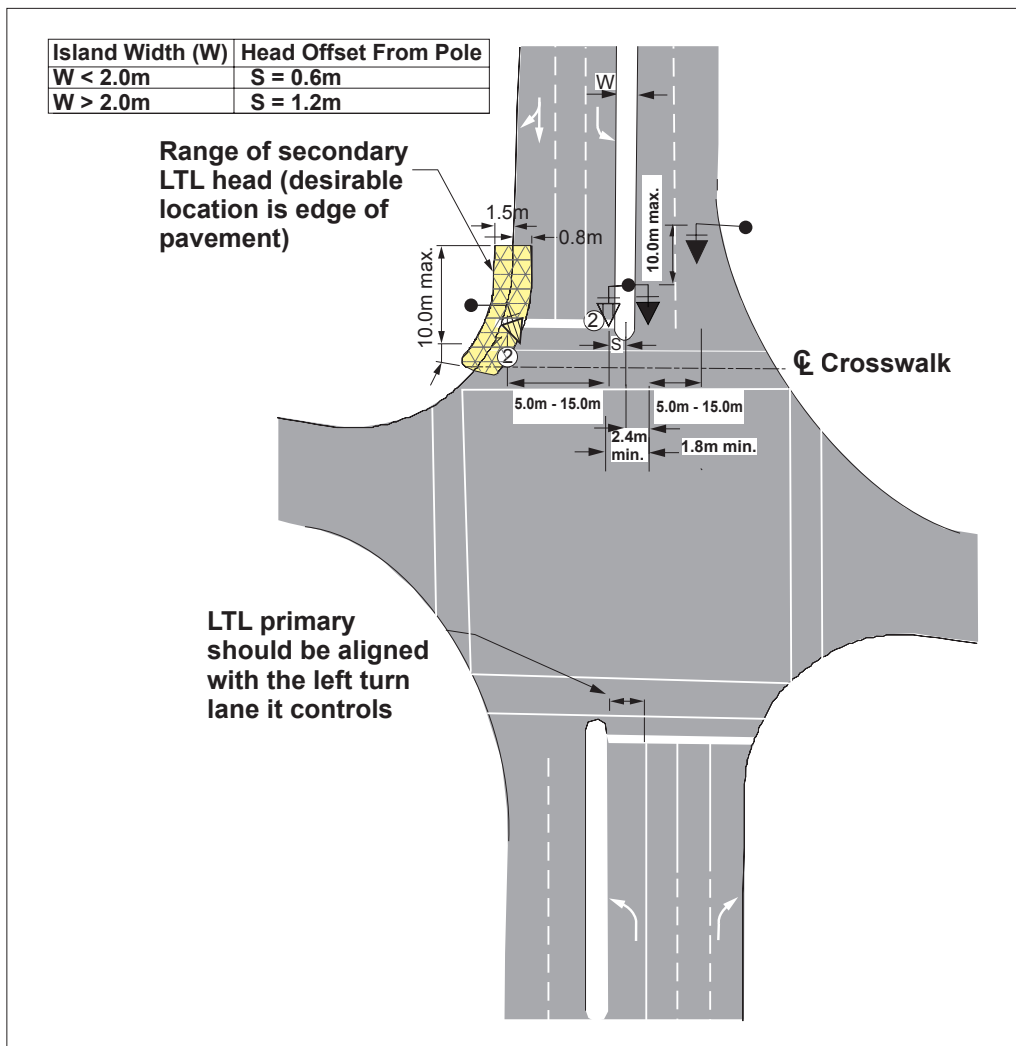

Figure 53 – Fully Protected Left Turn Approach

Approach with Wide Median (Fully Protected Left Turns)

Figure 54 shows a fully protected left turn layout for a wide median of between 2.0 m and 15.0 m. Note the following:

- The left-turn primary head, type 2, is to be located within the projection of the edge of pavement of the left-turn lane (LTL) and a point not more than the apparent end of the median island, as shown.
- A minimum separation of 3.0 m should be obtained between the LTL primary head and the through secondary head.
- The LTL secondary head should be over the edge of pavement by 0.8 m (preferred) and angled towards the LTL at the stop line or toward a point slightly upstream of the stop line.
- **Where the median width exceeds 15 m, two sets of separate signals are required in accordance with Section 144 (2) of the HTA.**

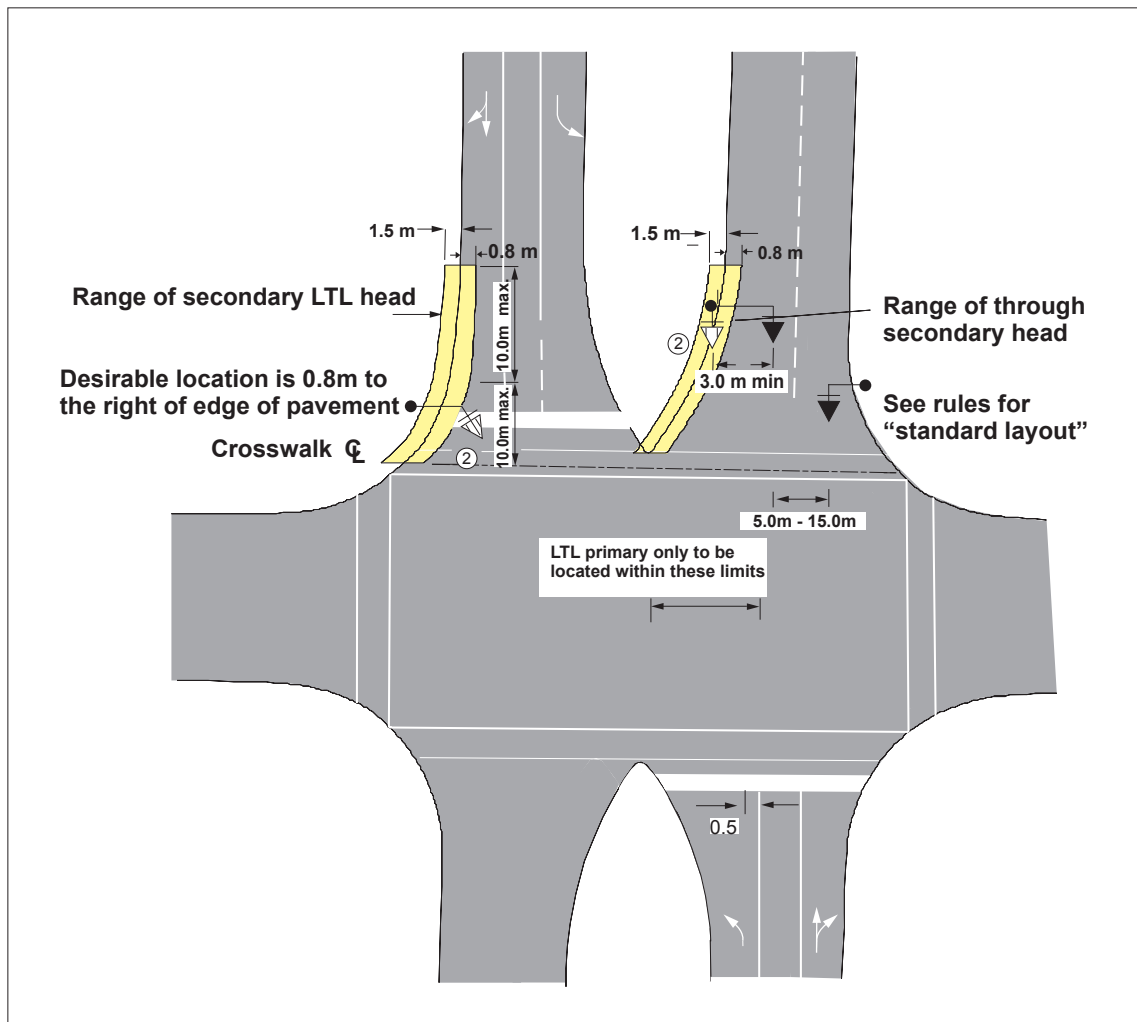

Figure 54 – Fully Protected Left Turn at Wide Median Approach

Approach with Double Left Lane (Fully Protected Left Turns)

Figure 55 shows a fully protected left-turn approach for a dual left-turn lane (LTL). Note the following:

- The mast arm length “S” for the LTL primary head depends on the median width “W” such that the distance between the LTL primary and the through secondary heads is a minimum of 2.4 m.
- The LTL secondary head should be over the edge of pavement by 0.8 m (preferred) and angled towards the LTL at the stop line or toward a point slightly upstream of the stop line.
- The dual LTL shall require pavement marked “tracking” lanes for guidance of turning vehicles. For safety purposes, where a dual LTL faces a simultaneous dual left from the other direction, there must be sufficient room to separate the outer tracking marks by at least 3.0 m.

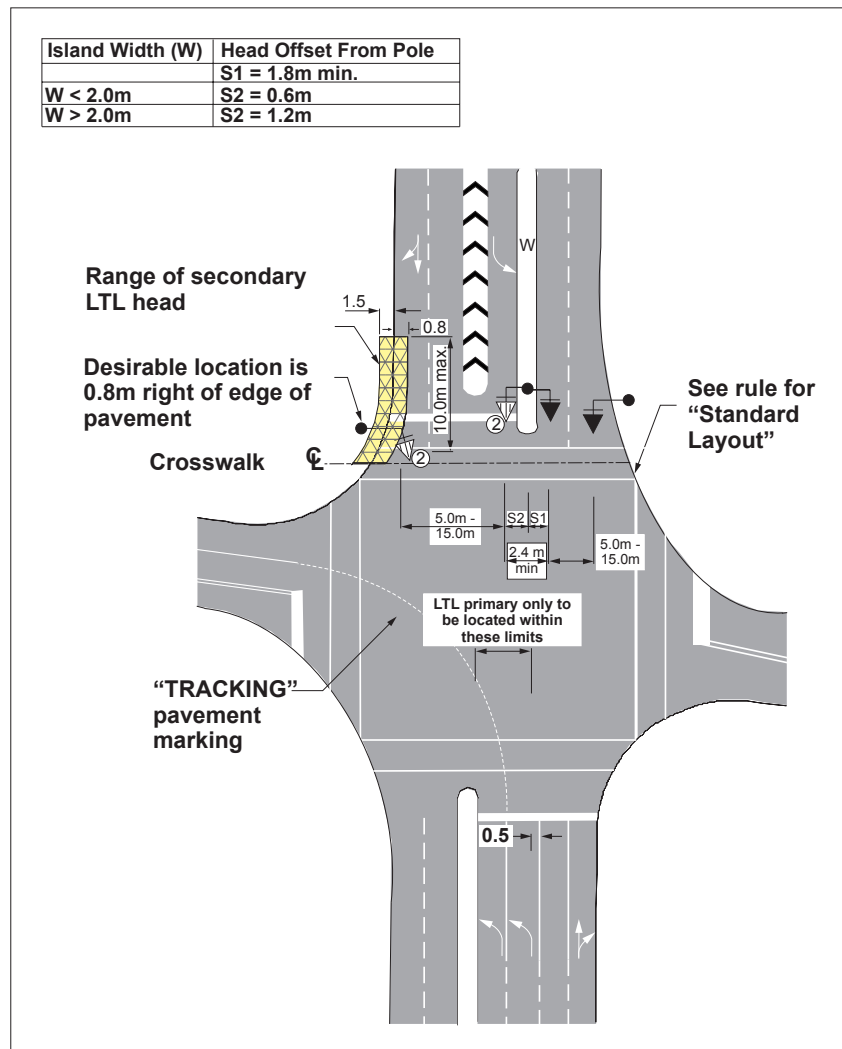

Figure 55 – Fully Protected Dual LTL Approach

Ramp Terminal

Figure 56 shows a full layout for a freeway ramp terminal on an exit ramp to an arterial. Note the following:

- The area between the extended edges of pavement of the ramp should preferably be kept free of poles.
- Typical Highway heads may be used on the arterial provided that proper signage for restricted turning movements is also used.
- Where turning traffic and pedestrian volumes allow, only one crosswalk should be used. It should be aligned on the approach where left-turning traffic from the ramp will not interfere with the crossing.
- Where a double lane left or right turn is allowed, the left and right turn lanes should not flow simultaneously with conflicting pedestrian crossings.
- The through lane primary and secondary heads on the arterial should be the type that indicates that no turns are to be made.
- Arterial secondary heads mounted on median poles require side mounted mast arms of at least 0.6 m length. This is because the islands are in direct alignment, and the near median poles may obscure front mounted heads.

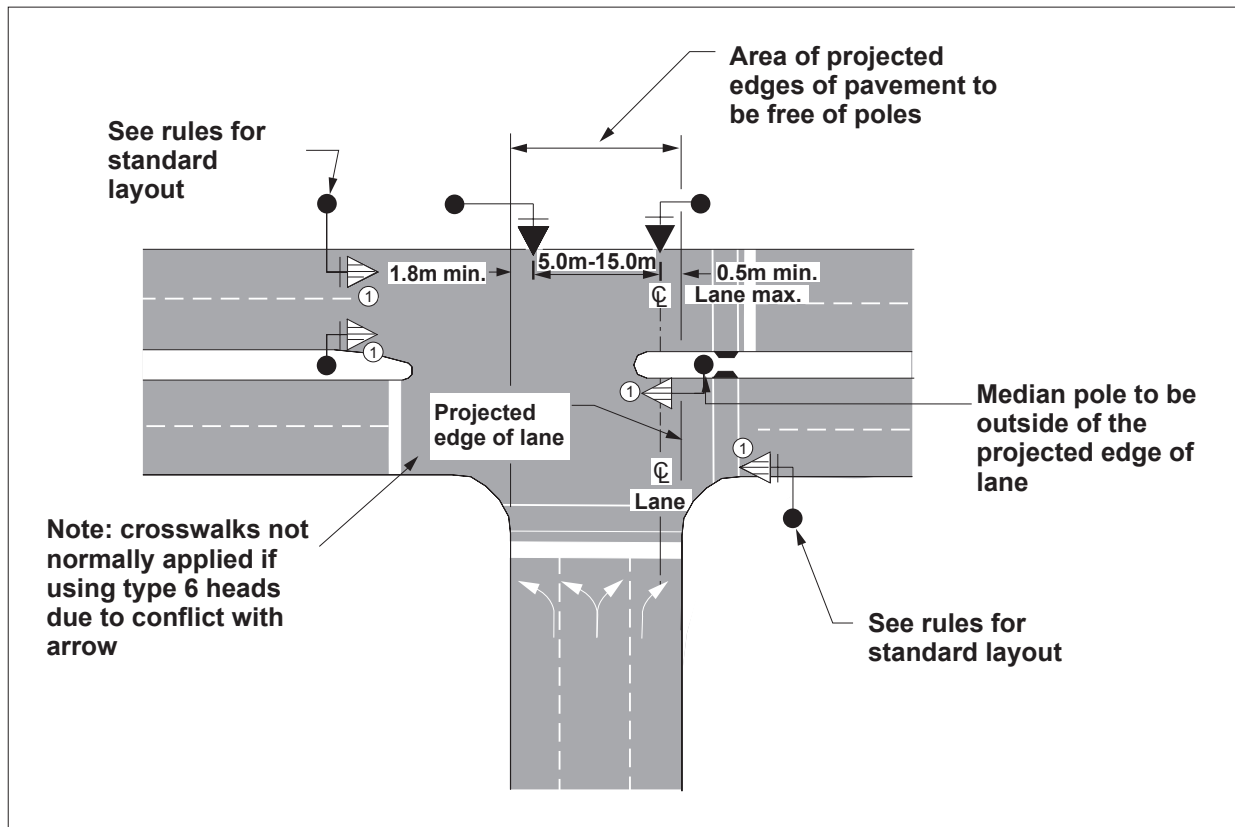

Figure 56 – Ramp Terminal Intersection Approach

Short Offset Intersection

Figure 57 shows a typical layout for a “short offset intersection” where one side road is offset from the other. The configuration shown has been termed a “far right” offset because the side road on the right of either approach is farthest from the motorist. A “near right” intersection is the opposite with the side road on the right being nearest the approaching traffic.

When installing traffic signals at a short offset intersection, note the following:

- The distance between the side roads can be treated similarly to a wide median. The maximum median width of 15 m for a single set of signals can be applied.
- Pedestrian crossings in the middle, i.e., between the side roads, are not desirable (with normal phasing). The side road approaches are typically served on separate phases, allowing pedestrian crossings

between the side roads during one of the phases. If pedestrian crossings are prohibited on the other approach, the phase for the “no-crossings” approach can be kept to a minimum, and the cycle length kept as low as possible.

- For visibility purposes, the distance from the stop lines to a primary head is limited to a maximum of 55 m. If the distance is longer, the intersection is a “long offset intersection”
- Pavement marking “tracking lines” should be used to reduce motorist confusion.

When a vehicle turns left from either side road, the motorist is confronted by a red light on the arterial and there may be confusion as to whether to stop. Advisory signage does not appear to solve this problem. The designer is directed to Metropolitan Toronto’s paper “Traffic Signal Control at Offset Intersections”²² for a more thorough treatment of the subject.

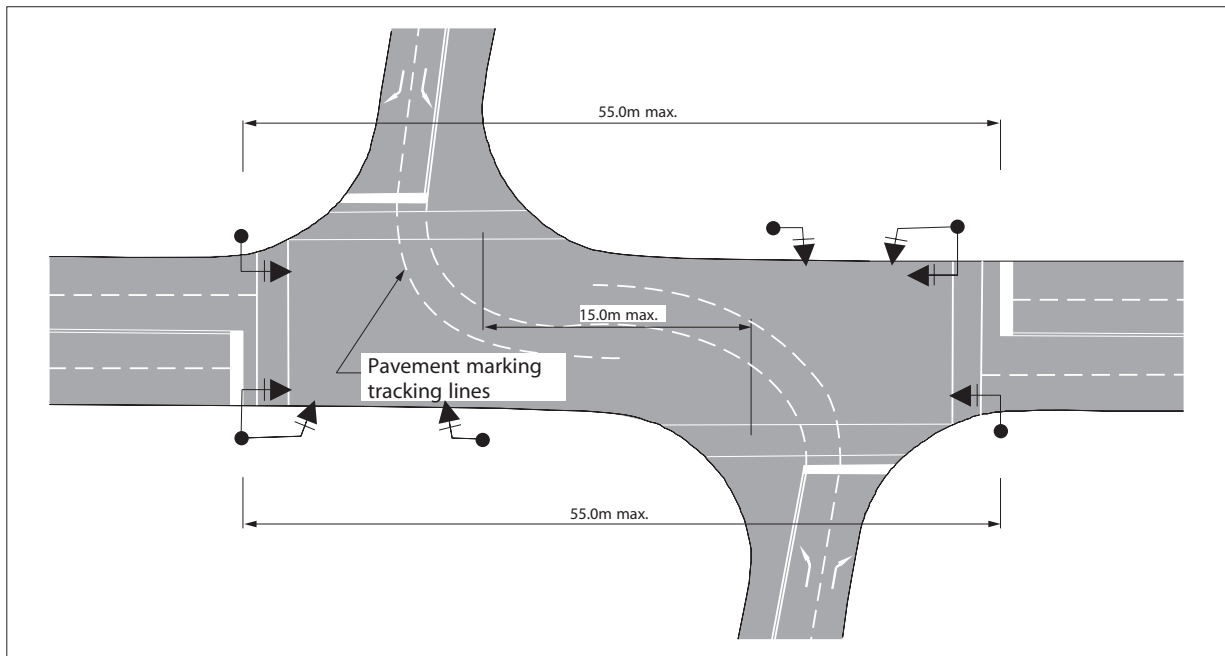

Figure 57 – Short Offset Intersection

Long Offset Intersection

Figure 58 shows a typical layout for a “long offset intersection” where one side road is offset from the other, but the offset (although longer than that of the short offset intersection) is not large enough to present entirely independent intersections to approaching motorists. These types of intersections may be divided into “far right” (as shown), and “near right” where the first side road on the right is the closest to the approaching traffic. The design of traffic control signals at this type of intersection may create confusion because two sets of signals face motorists. Note the following:

- Pedestrian crossings in the middle, i.e., between the side roads, are not desirable unless phasing times permit the holding of turning traffic while pedestrians cross.
- As the maximum viewing distance of 55 m for the primary head from the stop line cannot be obtained, independent sets of signals are required.
- The distance “D” should be as long as possible (15 m minimum is suggested) to accommodate storage of trapped vehicles.
- If the distances to the next intersections permit some variation in signal timing, detection could be added in the lanes between intersections to extend the green or let the next phase activate.
- The use of optically programmable signal heads combined with signal timing may help to reduce the problem of driver confusion created by two sets of closely spaced signals. Optically programmable signal heads on the far set of heads can help to hide the far set of heads from the view of approaching drivers. Signal timing that provides the amber indication for the upstream traffic before the amber for the traffic between the offset legs may also help.
- A subtle solution for motorist confusion may be to paint the far set of signal head housings a different colour than those of the near side, e.g., black faces on the far set, and yellow faces on the near set.
- Where “D” is less than approximately 200 m, it is difficult for the intersections to operate independently or in a system without coordinated timing, phasing, and efficiency. Refer to Metropolitan Toronto’s paper “Traffic

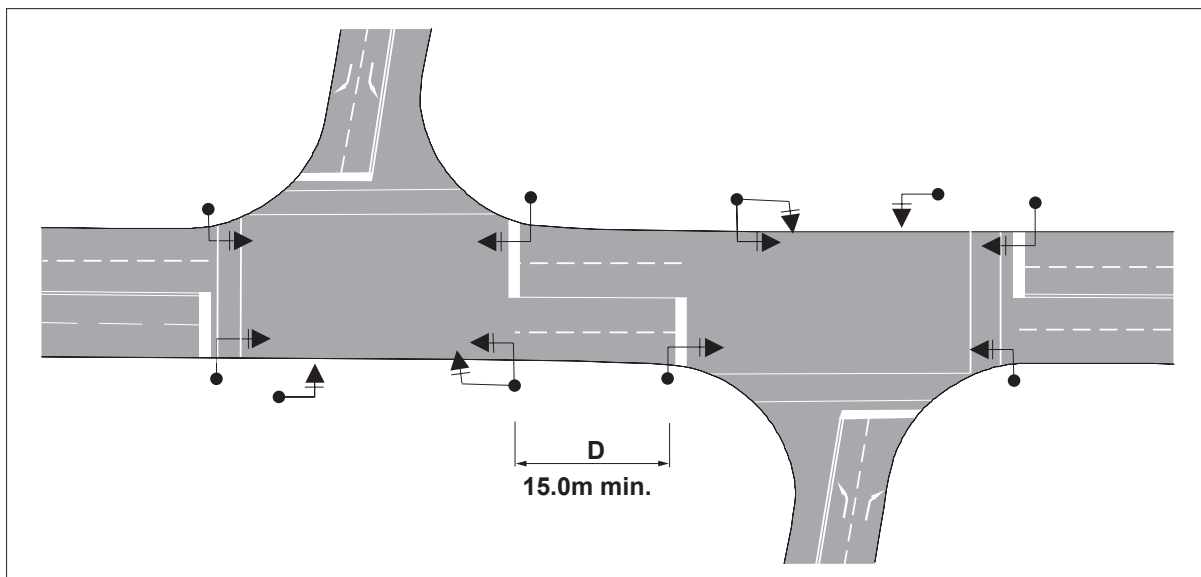

Figure 58 – Long Offset Intersection

Signal Control at Offset Intersections”²² for a thorough discussion of problems and solutions.

placing all hardware in convenient locations that are accessible, but out of the travelled portion of sidewalk.

Layout of Pedestrian Heads and Poles

General

To be effective, pedestrian heads must be easily noticed by pedestrians. This requires some standardization of pedestrian head locations with respect to crosswalks and sidewalks. Where pushbuttons are used, the buttons must be accessible and convenient to the crosswalk being served. Consideration should be given to

Poles with Pushbuttons

Figure 59 illustrates the principles that apply to the location of poles with pushbuttons. Poles with pedestrian pushbuttons should be located in accordance with the following guidelines:

- If possible, poles with pushbuttons should be within the extended crosswalk lines. If this is not possible, the poles should be located within 1.5 m of the edge of the crosswalk being served.

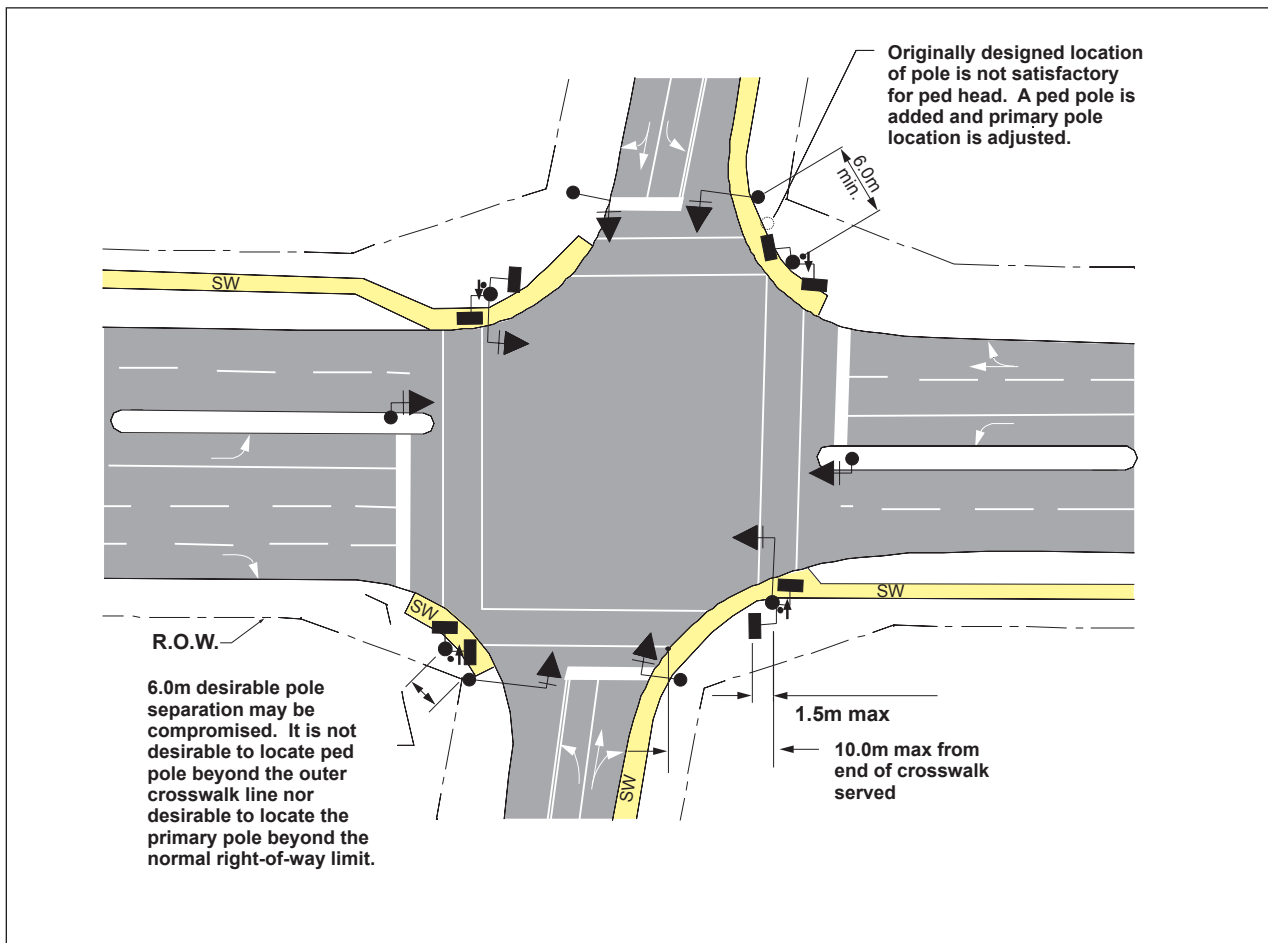

Figure 59 – Layout of Poles With Pushbuttons

- The poles should be located directly adjacent to, or within, sidewalks or other hard surface areas.
- The poles must be accessible and user friendly. They must not be located beyond reach behind barriers, or in grass (mud) areas, or in areas where snow windrows will occur. Some additional sidewalk or paved shoulder may be required.
- Where possible, it is desirable that pedestrian pushbuttons be mounted on traffic signal poles. Where a separate pole is required, the pole should be installed near the intersection of the centrelines of the crosswalks, and should include the pedestrian heads to avoid visual clutter. If this treatment is not possible, a short pole with pushbuttons only may be used.
- Where a separate pole is required, consideration should be given to locating it at least 6.0 m from other poles to allow room for maintenance vehicles to operate and also for aesthetic reasons.
- The designer should ensure that the pedestrian heads will not be visually blocked by vehicles at the stop line.
- Mounting pedestrian heads on the side of the pole nearest the pavement invites damage by errant large turning vehicles, snowplows, etc.
- The addition of pedestrian heads to poles that support other uses may require re-adjustment of the previously designed locations of these poles or even minor adjustments to sidewalk and crosswalk designs (for new construction only, not rehabilitation projects).

5.13 Controller Locations

Coordination

The location of the traffic signal controllers may require grading, re-routing of ditches, etc. Co-ordination with the road designer is required. For detailed information on controller location design, refer to the Ministry's Electrical Design Manual³.

Physical Requirements

Locations for controller cabinets must be designed with due consideration to safety, maintenance access, visibility of approaching traffic, service supply, grounding, and electromagnetic interference. The following general guidelines apply:

Poles with Pedestrian Heads

Poles carrying pedestrian heads should be located in accordance with the following guidelines:

- Ideally, pedestrian heads should be located within the extension of the crosswalk lines or at a maximum of 4.5 m from these lines.
- The poles should be located so that standard 38 mm dia. x 400 mm double arm brackets can be used for the pedestrian heads. The use of mast arms longer than 600 mm with hangers is discouraged (unless unavoidable) because of interference with maintenance vehicle operations.
- Pedestrian heads can be mounted on primary, secondary, or auxiliary poles as long as the heads are not more than 10.0 m longitudinally from the end of the crosswalk (see Figure 59).
- Where possible, controller cabinets should be located on the "far right" corner of the main road at the intersection. This location gives persons standing at the controller the best view of approaching traffic from both ways along the main road.
- Ideally, the head displays for 50% of the phases should be visible while standing at the controller.

- Where barrier or guiderails are not present, it is desirable to locate the controllers at a location that meets the clear zone requirements in the Ministry's Roadside Safety Manual²⁰ from the edge, or projected edge, of through lanes. Note that on road construction or reconstruction projects, it is sometimes necessary to modify the grading and drainage design to accommodate this requirement.
- Controllers should not be mounted on slopes steeper than 6:1 nor at an elevation difference of more than 1.0 m from the pavement.
- If possible, access to controllers should be directly off the shoulder or boulevard, without crossing ditches, berms, walls, etc. Where road work is included in the contract, widening of the shoulder area with earth and granular materials should be arranged with the road designer.
- Controllers should be located at a minimum distance from the ground electrodes at the supply points. Refer to the Ministry's Electrical Design Manual³ for grounding details.
- Controllers must be located at a minimum distance from overhead high voltage wires to mitigate electromagnetic field interference. Refer to the Ministry's Electrical Design Manual³ for details.
- It is undesirable to have controllers, supply poles, and primary poles in clusters in locations where they can be hit by an errant vehicle. In some locations, controllers may be sited at the proper offset distance from the edge of the pavement and immediately adjacent to the sidewalk.
- In congested urban areas (posted at 70 km/h or less), minimum clearances of 3.0 m from the edge of the pavement are desirable. If this is not practical, controllers should be located as close to buildings as practical, leaving

at least a 1.5 m wide sidewalk area. The controller locations should be clear of doors and store-front windows.

- Controllers to be installed on poles should be provided with hard surfaces at grade so that they can easily be cleared of snow and can be maintained and serviced without muddy conditions.
- Controllers to be installed at ground level should be provided with concrete pads and concrete or metallic pedestals in order to raise the bottoms of the cabinets above ground and out of the snow. (A 225 mm minimum is suggested, more in snow belts.)

5.14 Design Example

General

This section presents a design example for a typical intersection. The is in detailed format, and is intended to illustrate the principles of traffic control signal design. The example should not be applied to any specific intersection as each intersection has its own idiosyncrasies.

The example is an intersection that is to be reconstructed under a roadway contract, but the principles are equally valid and applicable to an existing intersection that is to be signalized. Practitioners are reminded to review Section 2 for guidelines regarding legal approval requirements.

Preparation of Base Plan

This section emphasizes the importance of the proper preparation of the base plan on which the signal design will be overlaid. The steps necessary to produce the base plan are as follows:

- Obtain the base plan and proposed alignment from the road designer. The plan should be complete with existing and new edges of pavement, islands, sidewalks, right-of-way, and limits of paving (existing conditions preferably differentiated from proposed conditions). It is not desirable to have other road design notes such as "Limit of Construction," nor items such as side slopes, drainage, or other roadway specific design features on the signal design plan. It is however, convenient to have limiting factors such as ditches on the plan.
- Obtain the locations of all existing utilities from the road designer or from the utilities coordinator. Obtain any known utility relocation proposals or obvious relocations required at this time (utility locations must be staked and verified during construction).
- Where applicable, obtain the details of the existing signal system from previous contract drawings, signal drawings or legal approval drawings.
- Carry out a site inspection with appropriate stakeholders, including the local power supply authority and the utilities coordinator. At this meeting, attempt to establish the basic routing of the final overhead electrical lines, the possible locations of power supply points, whether metering is required, whether utility pole mounting of the power supply cabinet is allowed, and whether any special details are required by the local supply authority. Try to determine the location of future utility poles that could be used for mounting signal arms. Note that final decisions are not usually possible at this time, but a good basis for the preliminary layout can normally be obtained for further coordination.

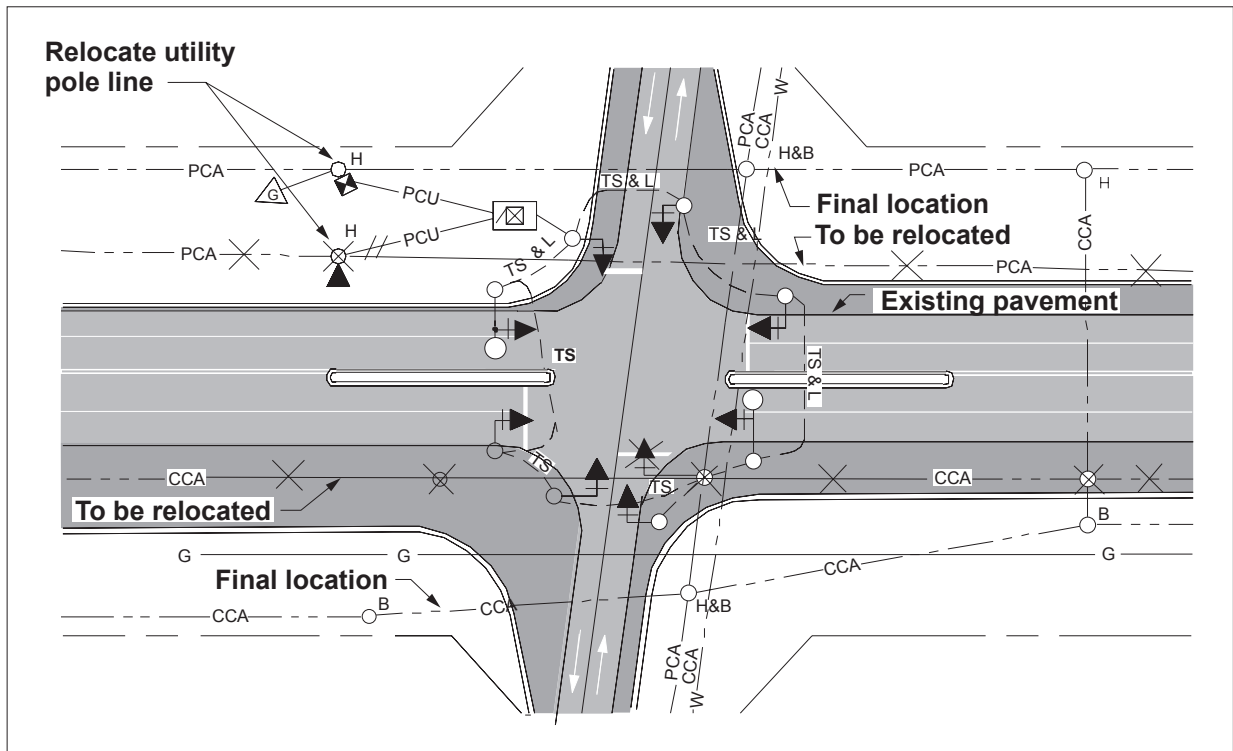

Figure 60 – Base Plan Features

- Note that if the project is for the installation of the traffic control signals only, the depths of the utilities may also be indicated on the plan.
- Plot all information accurately (to scale) on the base plan.
- The base plan, showing existing features, utilities, and relocations will be similar to the plan shown in Figure 60.

Note that it is the policy of some road authorities to have utilities relocated before construction. As the road/signal contractor is not usually on site when the utilities are being relocated, the relocation of the utilities may require prior relocation of the power supply cabinet and even minor relocations of the pole or mast arm by the electrical maintenance staff or by the pre-construction contractor. It is the designer's responsibility to prepare a sketch and outline of the work required and to bring these items to the attention of the roadway project manager and the person in charge of electrical

maintenance so that appropriate arrangements can be made for the work.

If the existing equipment is left in place as an interim measure, relocations may not be required.

Layout of Crosswalks and Sidewalks

The first step in the actual signal layout design is to lay out or confirm the locations of crosswalks, and to confirm or suggest the location of sidewalks. This section uses the principles given in Subsection 5.10 to discuss the layout of the crosswalks and sidewalks.

Figure 61 shows the layouts required and some suggested modifications for the sidewalk design. Note that the locations of the crosswalks and sidewalks are preliminary and remain to be coordinated with road designers. The signal layout must be undertaken to confirm the most desirable

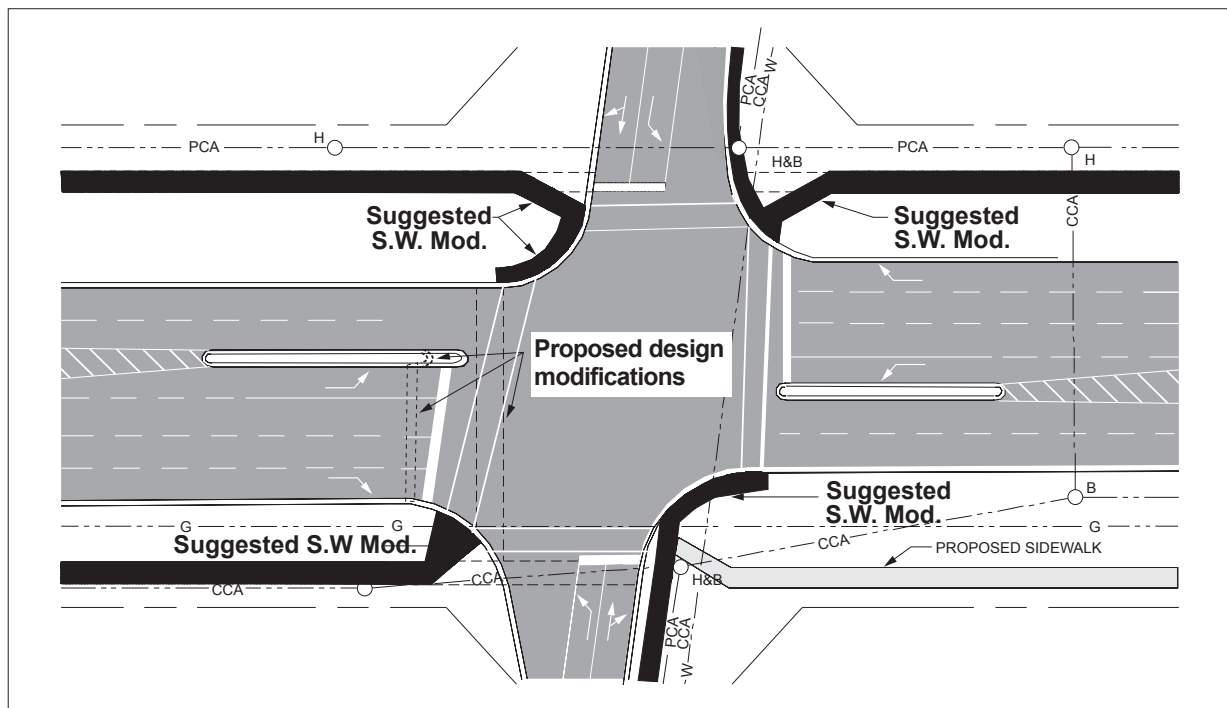

Figure 61 – Crosswalk and Sidewalk Modifications

sidewalk layout. A signal layout should also be prepared for cases where only signal provisions are to be installed.

Pole Locations

This section deals with locations where it is impossible or impractical to install traffic signal equipment. Poles are most prone to location restrictions due to the depth of the footings (possible interference with underground utilities) and the height of the poles (possible interference with overhead utilities).

It is important for the designer to recognize restricted areas at all stages of the design. It is suggested that the restricted pole locations be plotted directly in the working drawing before beginning the layout. Note the following:

- Utility clearance rules should follow the rules given in Subsection 5.11.
- The range of **restricted pole areas** should follow the information given in Section 5.6.

Figure 62 shows the example working plan with utility restrictions marked.

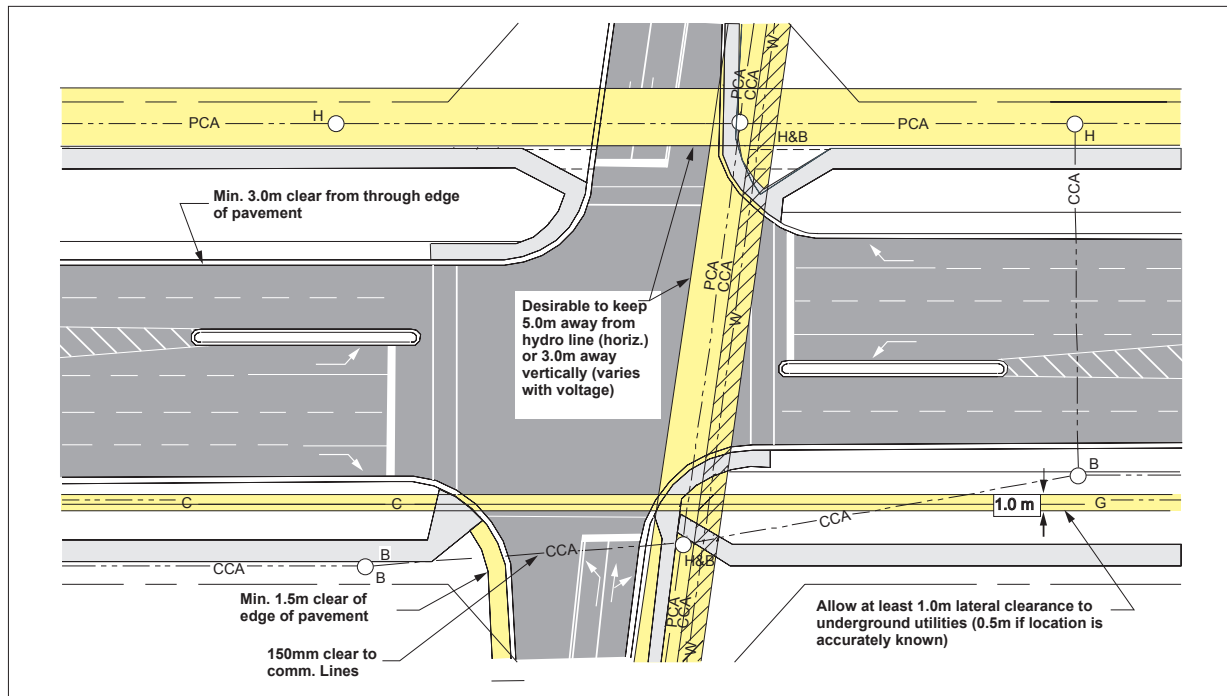

Figure 62 – Pole Locations Restricted by Utilities

Pre-set Head and Pole Locations

This section deals with signal head and pole locations, and follows the guidelines given in Subsection 5.3. The signal heads and poles are the first to be pre-set in any design. Figure 63 shows the standard locations where signal head and median poles should be placed.

Layout of Primary and Secondary Heads

Using the principles given in Subsections 5.6 and 5.12, the primary and secondary heads and poles are laid out as shown in Figures 64 and 65.

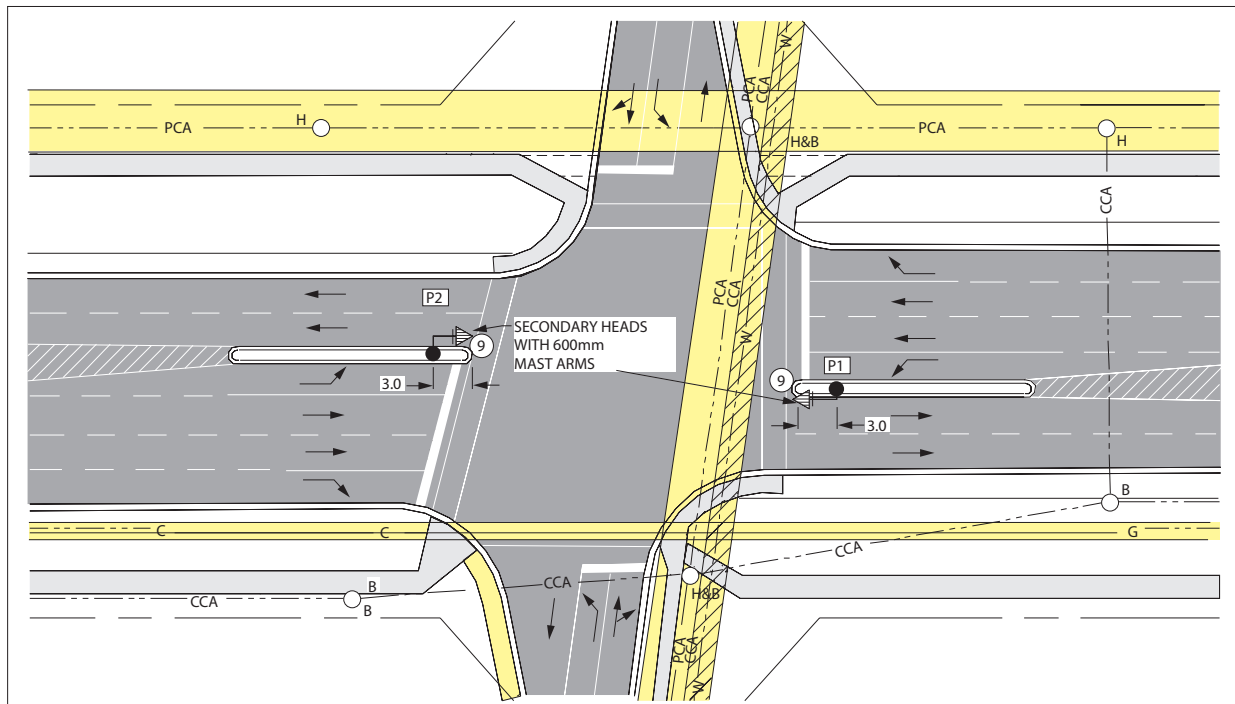

Figure 63 – Pre-set Signal Locations

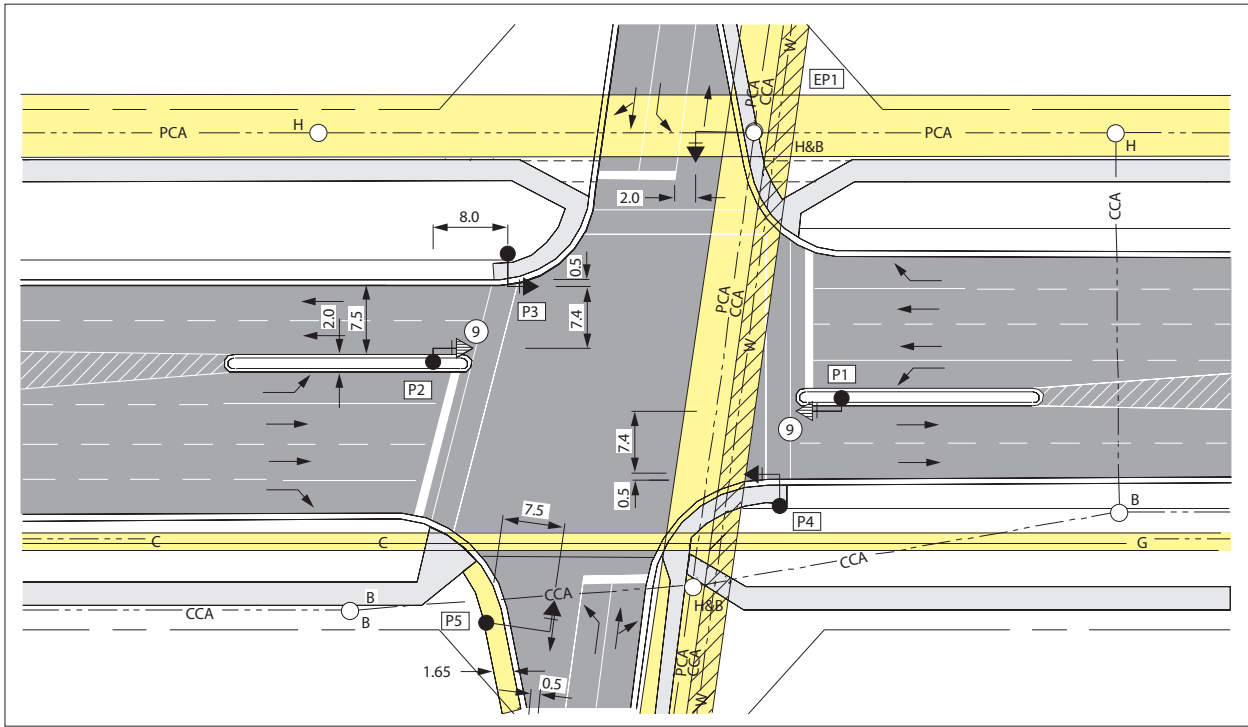

Figure 64 – Primary Head and Pole Layout

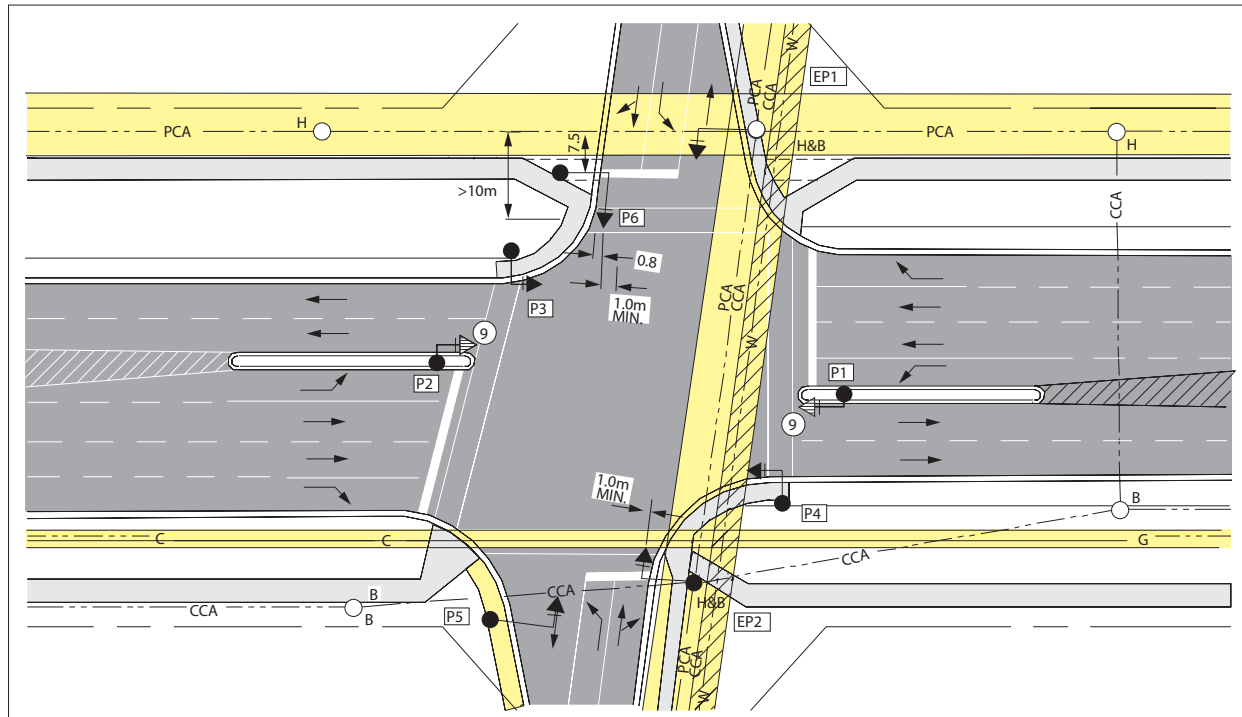

Figure 65 – Secondary Head and Pole Layout

Layout of Pedestrian Facilities

Using the principles given in Subsection 5.12, pedestrian facilities are laid out as shown in Figure 66.

Checking Layout

Figure 67 shows the checking of the layout design. Checking of the layout follows the principles given in Subsections 5.5 and 5.12. Figure 67 shows how the cones of vision should be checked to ensure that there are no blocked signal heads. The distances between heads and the pedestrian facilities should also be checked for conformance with the principles given in Subsection 5.12.

A checklist is provided in Appendix C.

Controller and Power Supply Locations

The controller should be located in accordance with the following principles:

- Strict attention should be paid to the principles of good grounding and relative freedom from interference from overhead hydro lines as given in Subsection 5.11. Additional details listed in the Ministry's Electrical Design Manual³.
- In areas of 80 km/h posted speed or greater, a controller offset of 10 m from the through edge of pavement is desirable. A 6 m offset is acceptable. As the controller location often interferes with ditches (the roadway should be visible from the controller site), coordination with the road designer is required (see Subsection 5.13).
- Electrical maintenance and traffic staff should be consulted as to their preference for cabinet orientation. Some prefer the front door to face

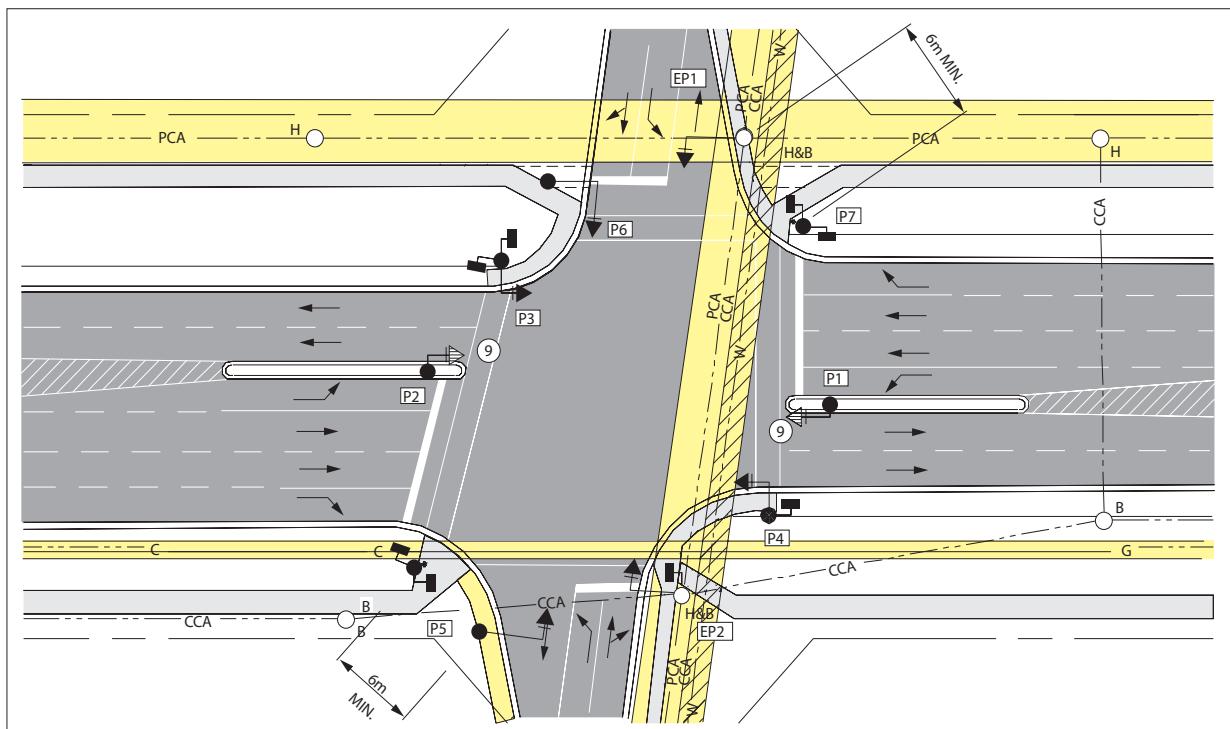

Figure 66 – Layout of Pedestrian Facilities

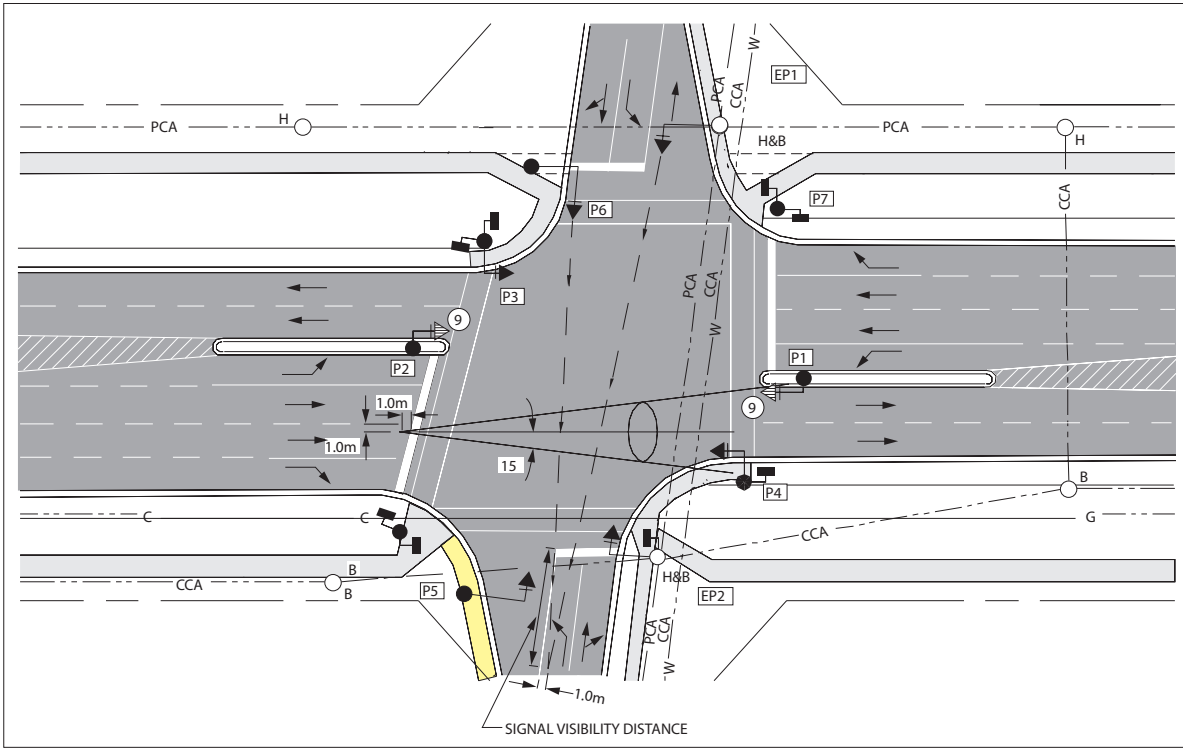

Figure 67 – Checking Signal Head Visibility and Layout

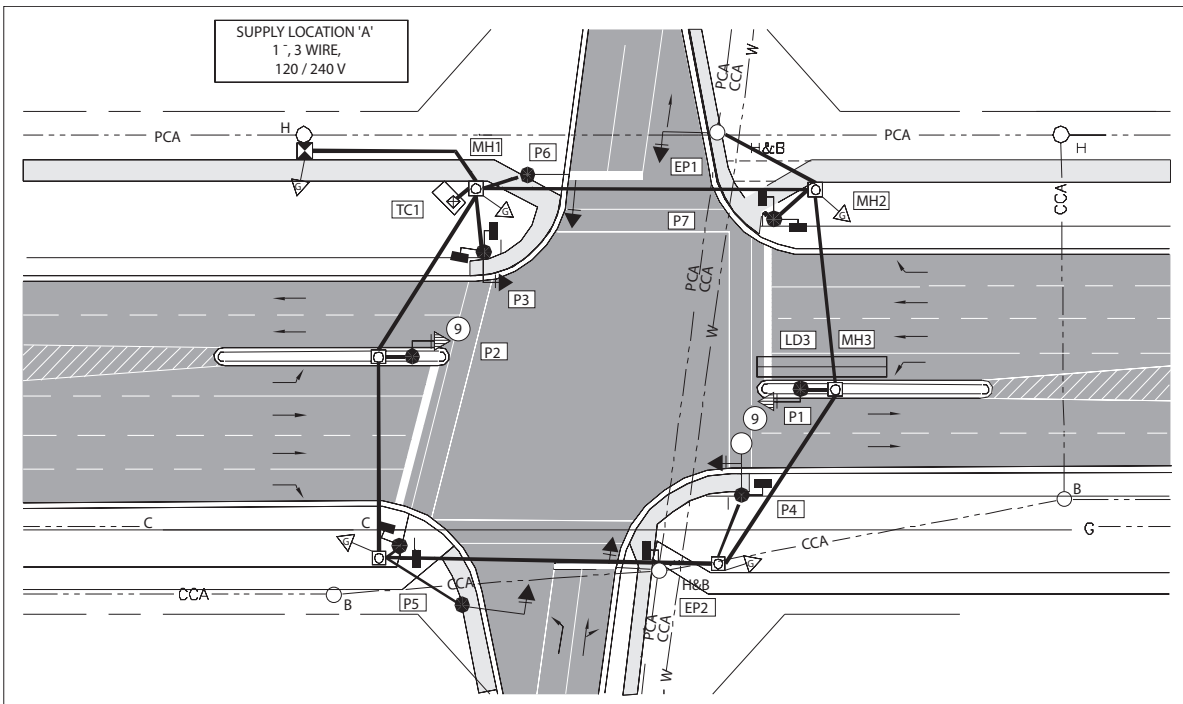

Figure 68 – Controller and Power Location

oncoming traffic, and some prefer to stand at the front door and face the intersection. Unless local policies dictate otherwise, the recommended location is at a 45° angle to the intersection, as shown in Figure 68.

- The location of the power supply pole has some bearing on controller location. To reduce the possibility of a double pole knock-down in a vehicle collision, it is desirable to have the power supply 75 m or less from the controller and the controller more than 11 m from the power supply pole.
- Separate ducts are required between the connection point and the controller where interconnection or traffic control system communication cables are used.

The power supply cabinet should be located in accordance with the following principles:

- The cabinet may be mounted within a ground mounted pedestal designed for a traffic signal controller. Standard communications pedestals are not strong enough for this application.
- The cabinet may be mounted on a utility pole if the local Power Supply Authority permits. It is preferred that the utility pole not have a transformer as the transformer ground can cause interference with the power supply ground. The local Supply Authority should be requested to install their grounds at least one pole span away. See the Ministry's Electrical Design Manual, Part 2, Chapter 9, "Grounding"³.
- The power supply cabinet should be within 75 m of the controller, and should be visible from both the controller and the roadway. The cabinet should also be located at least 10 m from the edge of pavement if possible.

Detector Layout

Detector loops are laid out as shown in Figure 69 for presence loops. On roadways posted at 80 km/h and over, extension loops for the dilemma zone are laid out as per Table 28. The loops are designed using the principles of the Ministry's Electrical Design Manual, Part 2, Chapter 2, "Vehicle Detection"³.

Figure 69 shows the detector loops laid out for the example intersection. Note that there are two ways to number the loops. One method numbers the loops clockwise beginning at the controller (as shown). This method corresponds with that used in some asset management system software. An alternative method uses the numbers of the phase movements served, and A, B, C, etc. for multiple loops serving a single movement common to the lanes involved.

Duct and Wiring Systems

Careful consideration must be given to the design of the underground ducts and electrical chambers. Careful consideration is required due to the high costs of underground ducts and electrical chambers, and the possibility of prolonged traffic interference, utility interference, and damage to roadbed structure caused by their installation or failure.

Underground ducts and wiring are not prone to damage from over-height vehicles and are aesthetically preferable to overhead wiring. The recommended practice for the design of duct systems is given in the Ministry's Electrical Design Manual, Part 2, Chapter 5, "Duct Systems"³.

Figure 70 shows the underground system designed for the example intersection.

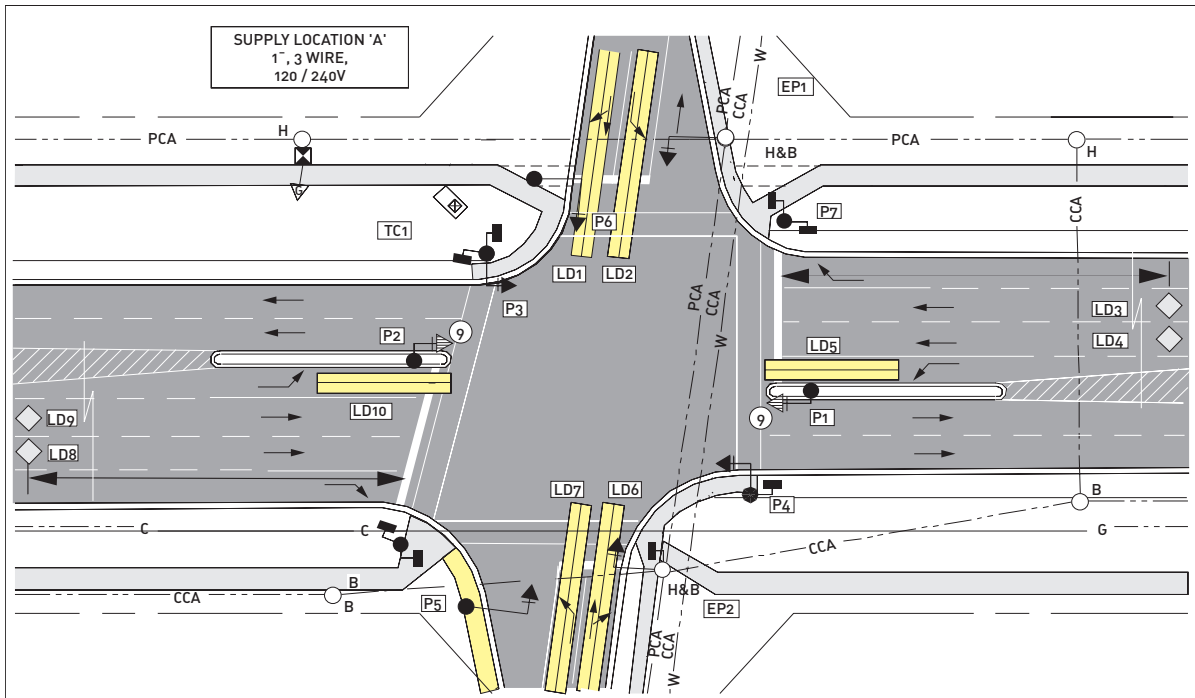

Figure 69 – Detector Loop Layout

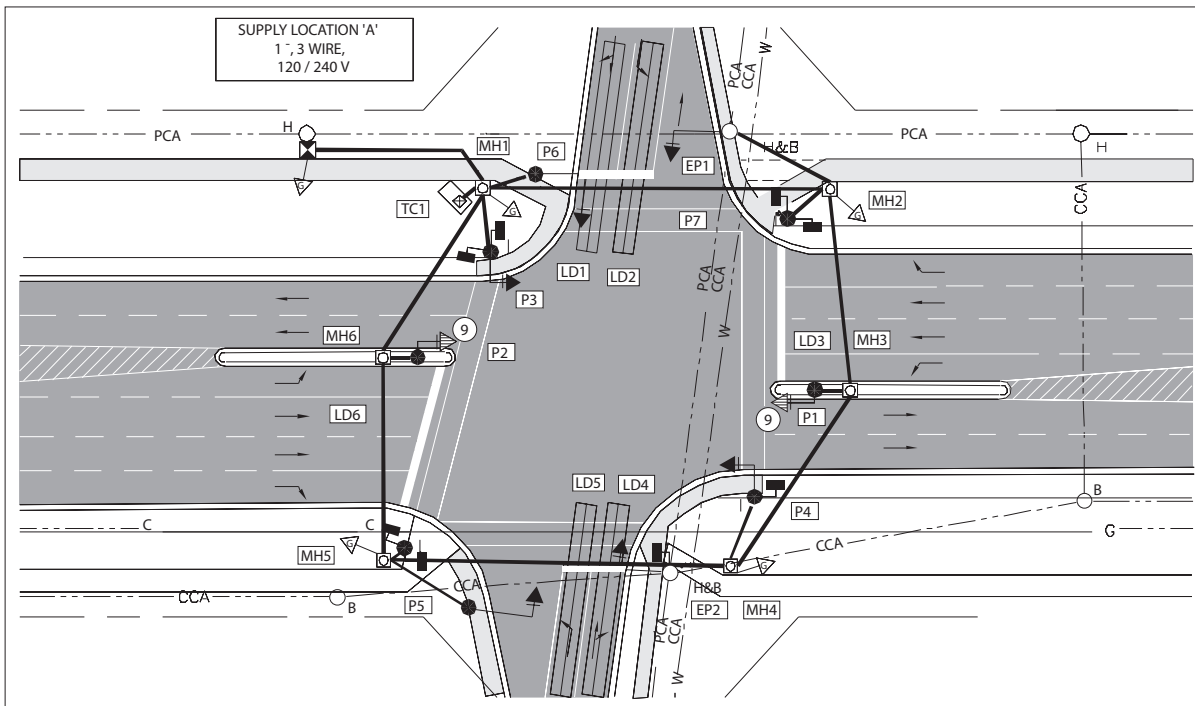

Figure 70 – Underground Duct System Layout

Coordination of Lighting Design

Roadway lighting is required at all signalized intersections. Either partial or full illumination will be required, depending on roadway and traffic conditions. Roadways at isolated rural intersections require at least two lighting luminaires to provide partial illumination. The lighting system should be integrated with the signals according to the following principles:

- Install the lighting on combination signal and lighting poles where possible. Utility poles may also be used if the supply authority allows this.
- All lighting on combination poles should be controlled from a combination power supply cabinet.
- Different voltages and different sources of supply are not allowed by the Ontario Electrical Code without multiple provisions.

- A #6 system ground for the signal pole interconnection is recommended to serve as the lighting system ground. The ground cable must be insulated to conform to the Canadian Electrical Code. Refer to the Ministry's Electrical Design Manual, Part 2, Chapter 9, "Grounding"³.

Figure 71 shows a typical partial lighting layout combined with the signals for the example. Partial lighting should be installed on the main road primary signal poles of each approach. The lighting is typically integrated on a combination or joint-use pole with the signals as indicated in Figure 71. Note that a small adjustment in the pole locations may be required to obtain the proper lighting and clearances. Otherwise separate poles may be installed as long as they are a minimum of 6 m from the signal poles and clear of utilities.

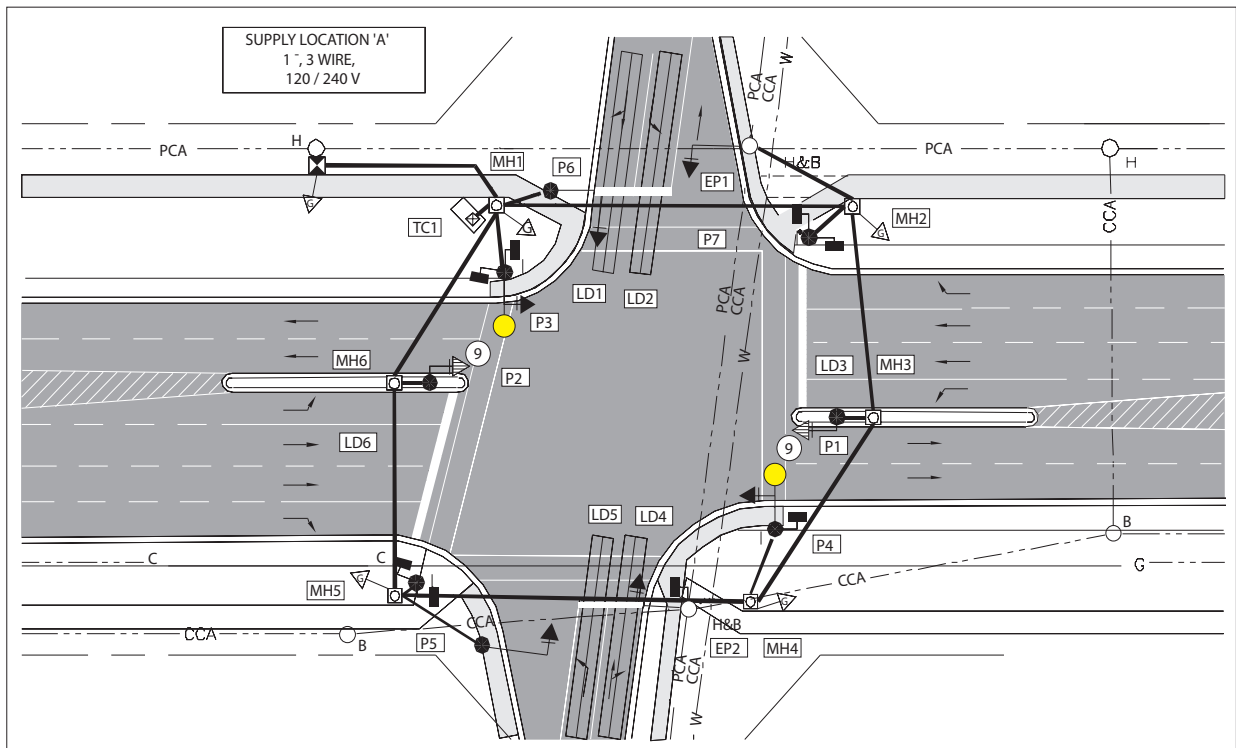

Figure 71 – Partial Lighting

**APPENDIX A
GLOSSARY**

ACRONYMS

AASHTO	American Association of State Highway and Transportation Officials	FHWA	Federal Highway Administration (U.S.A.)
AC	Alternating current	HCM	Highway Capacity Manual
AC+	120 V a.c., 60 Hz power bus	HOV	High occupancy vehicle
AC-	The 120 V a.c., 60 Hz neutral bus grounded at the power source	IPS	Intersection pedestrian signals
ASTM	American Society for Testing and Materials	ITE	Institute of Transportation Engineers
AWG	American Wire Gauge	LED	Light emitting diode
CCG	Canadian Capacity Guide for Signalized (Urban) Intersections	LOS	Level of service
CMOS	Complimentary metal oxide semiconductor	LTL	Left turn lane
CPU	Central processing unit	MIST	Management Information System for Traffic
CTS	Clear to send	MODEM	Modulate/demodulate communications interface unit
DCE	Data communications equipment	MOS	Metal oxide semiconductor
DCP	Data channel port	MOV	Metal oxide varistor
DDE	Data distribution equipment	MPU	Microprocessor unit
DHV	Design hourly volume	MTO	Ministry of Transportation, Ontario
DTE	Data terminal equipment	MTTR	Mean time to repair
EEPROM	Electrically erasable programmable read-only memory	MUTCD	Manual of Uniform Traffic Control Devices
EPROM	Erasable programmable read-only memory	NEMA	National Electrical Manufacturers Association
		OTM	Ontario Traffic Manual
		PCB	Printed circuit board
		PHF	Peak hour factor

PHV	Peak hourly volume
PIT	Pre-installation testing
POP	Proof of performance testing
PROM	Programmable read-only memory
PXO	Pedestrian crossover
RAM	Random access memory
RF	Radio frequency
RTS	Request to send
RXD	Receive data
SCOOT	Split Cycle Offset Optimization Technique
TAC	Transportation Association of Canada
TOC	Traffic Operations Centre (general)
TOD	Time of day
TTL	Transistor-transistor logic
TXD	Transmit data
UART	Universal asynchronous receiver/transmitter
VDS	Vehicle detection station

DEFINITIONS

Actuation:

The operation of a detector in registering the presence or passage of a vehicle or pedestrian.

All Red Interval:

The time in seconds of a red indication for all intersection traffic. It is used following an amber clearance interval to permit vehicles or pedestrians to clear the intersection before conflicting traffic receives a green indication.

Amber Clearance Interval:

The first interval following the green right-of-way interval in which the signal indication for that phase is amber. A clearance interval to warn approaching traffic to clear the intersection before conflicting traffic receives a green indication.

Cabinet:

An outdoor enclosure for housing a Controller Unit and associated equipment.

Call:

A registration of a demand for right-of-way by traffic (vehicular or pedestrian) at a controller.

Central Computer:

The combination of the application software, operating system, and computer hardware operating a traffic signal system from a single location.

Colour Sequence:

A predetermined order of signal indications within a cycle.

Concurrent Timing:

A mode of controller operation whereby a traffic phase can be selected and timed independently and simultaneously with another traffic phase.

Conflicting Phases:

Two or more phases that will cause interfering traffic movements if operated concurrently.

Conflict Monitor:

A device used to continually check for the presence of conflicting signal indications and to provide an output in response to conflict.

Controller:

The general usage term for the controller unit, cabinet, and associated appurtenances.

Controller Cabinet:

An outdoor enclosure used for the housing of a controller unit and all associated power, control, protection, activation, or interconnection devices.

Controller Unit:

That part of the controller which performs the basic timing and logic functions. A microprocessor based or electro-mechanical timing unit.

Coordination:

The control of controller units in a manner that provides a relationship between specific green indications at adjacent intersections in accordance with a time schedule to permit continuous operation of groups (platoons) of vehicles along the street at a planned speed.

Cycle:

Any complete sequence of traffic control signal indications. In an actuated controller unit, a complete cycle is dependent on the presence of calls on all phases. In a pretimed controller unit, a complete cycle is a complete sequence of signal indications.

Cycle Length:

The time (in seconds) required for one complete sequence of signal indications.

Cycle Splits:

The times in percent or seconds of the cycle for the phases making up the cycle.

Density:

A measure of the concentration of vehicles, usually stated as the number of vehicles per km per lane.

Detection Zone:

That area of the roadway within which a vehicle will be detected by a vehicle detector.

Detector:

A device for indicating the presence or passage of vehicles, including sensor device, lead-in cable, and detector sensor (amplifier) unit.

Detector Loop:

A detector that senses a change in inductance of its inductive sensor loop caused by the passage or presence of a vehicle in the detection zone of the loop.

Detector Memory:

The retention of an actuation for future utilization by the controller unit.

Detector Mode:

A term used to describe the operation of a detector channel output when a presence detection occurs: (1) Pulse Mode: Detector produces a short output pulse when detection occurs; (2) Controlled Output: The ability of a detector to produce a pulse that has a predetermined duration regardless of the length of time a vehicle is in the detection zone; (3) Continuous-Presence Mode: Detector output continues if any vehicle (first or last remaining) remains in the detection zone; (4) Limit-Presence Mode: Detector output continues for a limited period of time if vehicles remain in the detection zone.

Display:

A display consists of the total illuminated and non-illuminated signals facing the motorist. "Display" is interchangeable with "Indication."

Downloading:

The transmission of data from a master or central computer system to a slave or a remote Controller Unit.

Dwell:

The interval portion of a phase when present timing requirements have been completed. "Rest" as in "rest in green."

Extendible Portion:

In an actuated phase, that part of the green interval that follows the initial green portion when the initial green portion is extended by traffic actuations. If sufficient number of extensions occur, may reach Maximum Green.

Flasher:

A device used to open and close signal circuits at a repetitive rate.

Force Off:

A command to the controller unit that will force the termination of the current right-of-way (green) interval during the extendible portion.

Fully Actuated:

(1) A fully actuated mode of operation is one in which both the side (minor) road and the main (major) road use detection devices. During operation, if no actuation occurs at the intersection, the controller will either rest in the last phase actuated, or return to main road green to rest (recalled to main road green).
 (2) A fully actuated mode of operation can be one in which passage loops are used on all approaches, or on one of the roads if the other road has detection at the intersection.

Gap Reduction:

A controller feature whereby the unit extension or allowed time spacing between successive vehicle actuations on the phase displaying the green in the extendible portion of the intervals is reduced after each extension, usually in proportion to another parameter. Time Waiting Gap Reduction is a feature whereby the unit extension in the phase having the green is reduced in proportion to the time vehicles have waited on the phases having the red.

Hold:

A command to the controller unit which causes it to retain the existing right-of-way (green) interval.

Indication:

The illumination of a traffic signal lens or combination of signal lenses at the same time. The "display".

Initial Portion:

The first timed part of the green interval of an actuated phase.

Interconnected Controller:

A controller which operates traffic control signals under the supervision of a master controller.

Interconnection:

(1) A means of remotely controlling some or all of the functions of a traffic control signal. (2) An electronic, fibre optic, time synchronization, radio, telephone, or electrical connection with coordination units or modems in the controller cabinets; (3) the physical interconnection.

Interval:

A part of a phase that is individually timed by the controller unit.

Interval Sequence:

The order of appearance of signal indications during successive intervals of a cycle.

Loadswitch:

A device used to switch 120 volt power to the traffic control signal heads. Loadswitches are normally semi-conductor devices that are switched by a low voltage signal from the controller unit.

Main Road:

The roadway approach or approaches at an intersection normally carrying the highest volume of vehicular traffic (also called "Major Road").

Master Controller:

An automatic device for supervising a system of controllers, maintaining definite time interrelationships, selecting among alternative available modes of operation, or accomplishing other supervisory functions. A Master Controller controls one or more slave controllers.

Maximum Green:

The maximum time the right-of-way can be extended by actuations on a phase, provided an actuation has been registered on a conflicting phase.

Military Specification:

Current issues and/or revisions of standards or specifications issued by the U.S. Department of Defence.

Minimum Green:

The shortest time for which the right-of-way shall be given to a non-actuated phase, or to an actuated phase provided that an actuation has been registered for that phase.

Module:

A removable assembly with a fixed pattern of pixels, and identical to all other modules.

Motherboard:

A Printed Circuit Connector Interface Board with no active or passive components.

Movement:

A movement is the direction of traffic flow and may be straight ahead (a "through movement"), a green left arrow (a "left turn movement"), etc. Several movements may be allowed within a phase (e. g., an advanced green arrow and a circular green display). In some cases, a movement is called a phase as the movement is normally part of a phase.

Non-conflicting Phases:

Two or more traffic phases that will not be in conflict with each other if operated concurrently.

Offset:

The number of seconds, or the percent of cycle length, that a defined time-reference point (the "yield point," normally the start of main street green) at the traffic control signal occurs after the time-reference point of a master controller or of an adjacent traffic control signal.

Opposing Traffic:

Traffic progressing in the upstream or opposite direction to the traffic being considered on a roadway.

Overlap:

A right-of-way indication that is derived from the service of two or more traffic phases.

Passage Detection:

The ability of a vehicle detector to detect the passage of a vehicle moving through the detection zone and to ignore the presence of a vehicle stopped within the detection zone.

Passage Time:

(1) See Unit Extension. (2) The time allowed for a vehicle to travel at a selected speed from the detector to the stop line.

Pattern:

A unique set of coordination parameters including cycle length, split values, offsets, and sequence of intervals.

Pedestal:

Ground mounted enclosure for communications, or a support for a controller cabinet.

Pedestrian Clearance Interval:

The time in seconds during which the orange hand is flashed, starting after a walking pedestrian indication and ending before conflicting vehicles receive a green indication (may include the vehicle amber time).

Phase:

A part of a cycle where one or more traffic movements receive a green indication at the same time. Phase time is the time required from the start to the finish of the phase including amber and all-red interval times.

Phase Sequence:

A predetermined order in which the phases of a cycle occur.

Phase Skip:

A function used to provide omission of a phase in the absence of actuations on that phase.

Plan:

A unique set of timing values, intervals used, and sequence of intervals that is stored in or sent to a controller unit. Different plans may be used for time of day, time of week, special events and so on, or the plan may be traffic responsive as determined by detector actuation.

Poll:

An enquiry message sent from a master to a slave on a regularly timed basis to solicit the status of the slave.

Power Failure:

A power failure is said to have occurred when the incoming line voltage falls below 93 (+2) VAC for 50 milliseconds or longer. The determination of the 50 milliseconds interval shall be completed within 67 milliseconds of the time the voltage falls below 93 (+2) VAC.

Power Restoration:

Power is said to be restored when the incoming line voltage equals or exceeds 95 VAC for 50 milliseconds or longer. The determination of the 50 millisecond interval shall be completed within 67 milliseconds of the time the voltage first reaches 98 (+2) VAC.

Pre-emption:

The transfer of the normal control of signals to a special signal control mode for the purpose of servicing railway crossings, emergency vehicle passage, transit vehicle passage, and other special tasks, the control of which require terminating normal traffic control to provide priority needs of the special task.

Pre-emptor:

A device or program/routine which provides pre-emption.

Presence Detection:

The ability of a vehicle detector to sense that a vehicle, whether moving or stopped, has appeared in the detector's field.

Pretimed:

A controller unit mode of operation of traffic control signals with predetermined fixed cycle lengths, fixed interval durations, and fixed interval sequences.

Progression:

1) The time relationship between adjacent signals on a roadway that permits a platoon of vehicles to proceed through the signals at a planned rate of speed. 2) The act of various controller units providing specific green indications in accordance with a time schedule to permit continuous operation of groups (platoons) of vehicles along the road at a planned speed.

Red Clearance Interval:

A clearance interval which may follow an amber clearance interval that in theory allows time at the end of a phase for vehicles in the intersection to clear before release of a conflicting phase.

Right-of-way:

The operation of a controller in causing traffic control signals to display indications permitting vehicles or pedestrians to proceed in a lawful manner in preference to other vehicles or pedestrians.

Semi-actuated:

Operation by a type of traffic-actuated controller in which means are provided for traffic actuation on one or more but not all approaches to the intersection.

Side Road:

The roadway approach or approaches at an intersection normally carrying the least volume of vehicular traffic (also called "Minor Road").

Signal Indication:

The illumination of one or more lenses in a signal head which conveys a message to traffic approaching the signal from one direction.

Slave Controller:

A slave controller is an intersection traffic signal controller that is locally programmed to suit the interval times required at the intersection, but is

set on the phasing and timing of the system as determined by the master controller or central computer.

Split:

For an actuated controller unit, split is a division of the cycle length allocated to each of the various phases (normally expressed in percent). For a pretimed controller unit, split is the time allocated to an interval.

System:

A traffic signal system is composed of a number of traffic signal controllers operating from electronic instructions given by a master controller at one of the intersections or by a central computer at a traffic control/operations centre. A system may be installed on a single roadway with one master controller and one or more slave controllers, or on a grid of roadways using either a master controller or a central computer. A system may use interconnection methods, telephone, television networks, or any combination thereof for communications transmission of data commands to the local slave controllers.

Through Band:

The time period between the passing of the first and last possible vehicle in a group of vehicles moving in accordance with the designed speed of a signal progression.

Time Base Control:

A means for automatic selection of modes of operation of traffic control signals in a manner prescribed by a predetermined time schedule.

Traffic Control Signal:

Any power operated traffic control device, whether manually, electrically, or mechanically operated, by which traffic is alternately directed to stop and permitted to proceed. Traffic Signal: 1) When used in general discussion, a traffic signal is a complete installation including signal

heads, wiring, controller, poles and other appurtenances. 2) When used specifically, the term traffic signals refers to the signal head that conveys a message to the observer.

Unit Extension:

The timing period during the extendible portion of a right-of-way interval that is resettable by each detector actuation within the limits of the maximum period (extension limit).

User-definable Parameters:

Parameters which can be modified on-line by the user via some interactive dialogue with the system.

Watchdog:

A circuit or timer that is used to watch that an appropriate action is taken on a regular basis.

Yield:

A command that permits a controller unit to transfer right-of-way.

APPENDIX B REFERENCES

REFERENCES

1. **Canadian Capacity Guide for Signalized Intersections (3rd Edition)**, Institute of Transportation Engineers, District 7 – Canada, 2008.
2. **Development of New Crash Experience Warrants for Traffic Signals for Ontario**, Hadayeghi A, B. Malone, and R. DeGannes, TRB Transportation Research Record, Journal of the Transportation Research Board No. 1953, Washington D.C., 2006.
3. **Electrical Design Manual**, Ministry of Transportation, Ontario, 1989.
4. **Electrical Maintenance Manual**, Ministry of Transportation, Ontario, 1989.
5. **Geometric Design Standards for Ontario Highway**, Ministry of Transportation of Ontario, 1999.
6. **Greenshields, B. D.** "Traffic Performance at Urban Street Intersections," Yale University, New Haven, CT, 1947.
7. **Guidelines for the Planning, Design, Operation and Evaluation of Reversible Lane Systems**, Transportation Association of Canada, 2010.
8. **Guidelines for Understanding, Use and Implementation of Accessible Pedestrian Signals**, Transportation Association of Canada, 2008.
9. **Guidelines for the Application and Display of Transit Signals**, Transportation Association of Canada, 2008.
10. **Highway Traffic Act (HTA)**, Office Consolidation, Revised Statutes of Ontario, 1990, Chapter H.8 and the Regulations thereunder (as amended); Queen's Printer for Ontario.
11. **Highway Capacity Manual**, Transportation Research Board, 2010.
12. **Information Report on Pedestrian Countdown Signals (PCS)**, Transportation Association of Canada, 2008.
13. **Manual of Uniform Traffic Control Devices**, U.S. Department of Transportation, 2009.
14. **Manual of Uniform Traffic Control Devices**, Transportation Association of Canada, 1998, as amended.
15. **Ontario Highway Bridge Design Code**, Ministry of Transportation, 1995.
16. **Ontario Provincial Standard Drawings**, Volume 4, Electrical Drawings, Division 2000. Ministry of Transportation, Ontario and Municipal Engineering Association.
17. **Ontario Traffic Signal Control Equipment Specifications**, Ministry of Transportation, Ontario, 1994.
18. **OTM Book 7 "Temporary Conditions"**, Ministry of Transportation Ontario, 2001.
19. **Preemption of Traffic Signals At or Near Railroad Grade Crossings with Active Warning Devices**, Recommended Practice For, ITE, 1997.
20. **Roadside Safety Manual**, Ministry of Transportation, Ontario, 1995.
21. **The Science of Highway Safety Network Evaluation and Safety Conscious Procedure**, Ministry of Transportation of Ontario, 1997.

- 22. Traffic Signal Control at Offset Intersections**, Report to Transportation Committee, Metro Transportation, 1991.
- 23. Traffic Control Systems**, NEMA Standards Publication No. TS 1, National Electrical Manufacturers Association, 1989.
- 24. Traffic Controller Assemblies**, NEMA Standards Publication No. TS 2, National Electrical Manufacturers Association, 1992.
- 25. Traffic Engineering Handbook**, Institute of Transportation Engineers, 2009.
- 26. Transit Signal Priority (TSP)**, U.S. Department of Transportation, 2005.

**APPENDIX C
SIGNAL DESIGN AND DRAWING
CHECKLIST**

REQUIREMENTS AND REVIEW PROCEDURES FOR TRAFFIC CONTROL SIGNAL DRAWINGS

Requirements

1. Signal drawings should be on Form PHM-125 or similar form with CAD drawings preferred.
2. Preferred scale is 1:500 for rural intersections, and 1:250 or 1:200 for urban intersections.
3. Title block with correct road names should be above signature block.
4. Signature block should be on lower right hand side of the drawing, and should be visible when drawing is folded.
5. Correct HTA should be shown. Currently HTA 144 (31) must be on the signature block.
6. The signature of the person designated to approve the design under HTA 144 (31) is required on the drawing.
7. A north point is required.
8. Correct road names must be used as the drawing may form a legal document. The title block and body of the drawing must agree.
9. A chart for listing revisions should be on the drawing. Persons carrying out revisions should list them here and enter their signature and date on the revision.
10. A chart indicating equipment specifications, such as mast arm lengths, mounting height, special heads, etc., is required.
11. A chart for special arrow heads should be used on drawings where such heads are used. If a chart is not on the drawing, a key for special heads must be shown.
12. All symbols used on the drawing must be indicated on a key chart.

13. Any signing that is critical to the traffic signal operation, e. g., left-turn signs adjacent to left-turn signal heads for fully protected left-turn lanes, overhead signing for dual left-turn lanes, and active advance warning signs, should be included.

Review

1. Geometrics

- Geometries should be acceptable for signal head placement.
- Drop curbs, etc., are identified, and appropriate curb radius are shown.
- Offset side roads are shown if part of signal.
- Private entrances are shown if part of signal. Heads must be used.
- Residential entrances are shown. Note: residential entrances do not require signal heads, but if they are used or rezoned for commercial purposes, and if they are for public use, heads must be provided.
- A split entrance (two entrances, one on each side of the same approach with each one allowing an in and out movement) are not allowed to operate within the lateral curb lines of a signalized intersection or intersection to be signalized.
- Pavement widths should be adequate.
- Left-turn lanes may not be opposite through lanes.
- Truck turning lanes should be adequate.
- Median islands and channelized islands must not obstruct through lanes.

2. Zone Painting

- Zone painting must be safe, and may not create restricted or conflicting movements.
- Zone painting should be legible.
- Temporary drawings may be exempted from the zone painting scheme if it is not feasible to show the paint during staging.
- Stop lines and pedestrian crosswalks should be indicated.

3. Equipment

- All signal heads and equipment should be under HTA. It is always recommended that the primary head should be a highway head with backboard.
- The secondary head may be a standard head with no backboard, but it is preferred that a highway head be used here also.
- All equipment must be standard as specified in the Ontario Traffic Manual and design manuals.
- Auxiliary heads may be added if required, e.g., visibility restrictions, curves, etc.
- Special heads must have the correct number indicated as per special arrow chart. If there is no chart, a key must be drawn showing the lens display and lens sizes used.
- If pedestrian heads are used, they must be indicated.
- Push buttons must be shown if pedestrian actuation is required. Arrows indicating the direction of pedestrian pushbutton actuation are usually shown on the drawing.

4. Detection

- Presence detection is indicated on the side road.
- Presence detection is indicated in left-turn lanes if left turn phasing is required.
- Long distance loops are used on the highway if needed to extend the amber display (safe passage).
- Microwave, infrared, and video detectors are used by various municipalities, but most municipalities prefer presence loops and are the recommended choice.
- Microwave detectors can be useful for private driveways and temporary signals where permanent routes may not be possible or the pavement is too poor to cut loops.
- Emergency vehicle preemption detectors are shown facing the direction of travel in which they are used.
- Railway preemption may be required if a railway crosses or is close to a proposed signalized intersection.

5. Phasing

- Phasing appropriate to the design may be used.
- Phasing should not create conflicting traffic movements.
- Phasing must never compromise the safety of pedestrians.

